

Coolant pump

Instruction Manual

Notice

Please submit this manual to the customer performing operation, maintenance, and inspection of the pump.

Coolant Pump

Safety Precautions

Thank you for purchasing the coolant pump.

This pump has been designed with an outstanding electrical and mechanical performance, and detailed caution has been taken during manufacture to ensure safe use.

Please read this instruction manual and other enclosed documents carefully before installing, operating, maintaining, or inspecting the coolant pump, and use it correctly. Before using the pump, familiarize yourself with its safety instructions, and all precautions. After reading this manual, be sure to keep it in a place where it can be referred at any time.

The safety precautions are classified into two categories: "DANGER" and "CAUTION" in this instruction manual.



DANGER

A potentially hazardous situation that could result in fatal or major injuries if mishandled.

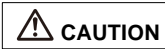

CAUTION

A potentially hazardous situation that may result in minor or moderate injuries if mishandled or may lead to property damage only.

Note that even items marked with  may lead to major results depending on the circumstances. Please follow the instructions of both levels because they are important to personnel safety.

 Danger
<p>[General]</p> <ul style="list-style-type: none">● Do not use this coolant pump in an explosive atmosphere. Use an explosion-proof motor for that type of atmosphere. Failure to observe this could lead to injury or fire.● Do not work with live wires. Always turn the power OFF before starting work. Failure to observe this may result in electric shock.
<ul style="list-style-type: none">● Transportation, installation, piping and wiring, work/operation, and maintenance /inspection should be performed by qualified personnel.
<p>[Piping and wiring]</p> <ul style="list-style-type: none">● Securely connect the power cable. (Make sure that the screws are not loose). Failure to observe this may result in electric shock or fire.● Do not forcibly bend, pull or pinch the power cable or motor lead wire. Failure to observe this may result in electric shock.
<p>[Installation and adjustment]</p> <ul style="list-style-type: none">● Ensure that the grounding terminal is securely grounded. Failure to observe this may result in electric shock.
<p>[Operation]</p> <ul style="list-style-type: none">● Do not operate the coolant pump with the terminal box cover removed. After work, return the terminal box cover to its original position. Failure to observe this may result in electric shock.● Do not approach or touch rotating parts such as a shaft while the pump is running. Failure to observe this may result in entanglement and cause injury.● In the event of a power failure, be sure to turn off the power switch. Failure to observe this could lead to an injury.

Caution

[General]

- Do not use this pump outside its specifications. Failure to observe this may result in electric shock, injury or damage.
- Do not put your fingers or objects into the motor or pump openings. Failure to observe this may lead to an injury or damage.
- Do not use a damaged pump. Failure to observe this could lead to an injury or fire.
- Any modifications made to the product by the customer are outside the scope of the warranty by TERAL INC. and we shall not be held responsible.

[Shipment and transportation]

- Dropping or tipping the pump during transportation may create a hazardous situation, so please handle it with special care.
- If the pump is provided with lifting bolts, always use them when lifting the pump. However, do not lift the entire pump after it has been installed in the machine. Check the pump weight before lifting it. Do not lift a pump that exceeds the rated load of the lifting equipment.

[Unpacking]

- Before unpacking, check the orientation. If the package is crated, be careful of nails during unpacking. Failure to observe this could lead to an injury.
- Confirm the delivered product is as ordered. Installation of an incorrect product could lead to an injury or damage.

[Installation and adjustment]

- When using the star-delta starter, select one that has an electromagnetic switch (three-conductor type) on the primary side. Failure to observe this may result in fire.
- When operating with an inverter, do not run the pump at a frequency exceeding 60 Hz. Failure to observe this may cause an overload and burnout of the motor.
- Do not place flammable objects around the motor. Failure to observe this could lead to fire.
- Do not place any obstacles around the motor that may block the ventilation. Inadequate cooling may cause overheating, which can lead to burns or fire hazards.
- When installing the pump onto the machinery, fix it securely with screws through the mounting holes on the pump flange.
- Do not step on the motor. Install a cover so that the rotary sections are not contacted. Failure to observe this could lead to injury.
- In the event of an oil leak, significant damage may occur. Please carry out oil-proof treatment and waste oil treatment accordingly.

[Piping and wiring]

- Perform wiring work in accordance with the applicable electrical equipment technical standards and interior wiring code. Failure to observe this could lead to burnout or fire.
- The motor is not equipped with a protection device. According to electrical equipment technical standards, an overcurrent protective device must be installed. It is recommended to install an additional protective device, such as an earth leakage circuit breaker, in addition to an overcurrent protective device.

Caution

[Operation]

- The motor becomes very hot during operation. Be careful not to touch the motor with your hands or body. Failure to observe this could lead to burns.
- Stop operation immediately if any abnormality occurs. Failure to observe this may result in electric shock, injury, or fire.
- For VKN type, do not operate the pump without liquid (dry-run) for more than 30 seconds. Failure to observe this may result in damage or fire caused by overheating of the mechanical seal.

[Maintenance and Inspection]

- When measuring the insulation resistance, make sure the power is completely turned off, and do not touch the terminals with bare hands. Failure to observe this may result in electric shock.
- Do not touch frame of the motor with bare hands as it becomes extremely hot during operation. Failure to observe this could lead to burns.

[Repair, disassembly, and modification]

- Repair, disassembly, and modification must be performed by qualified personnel. Failure to observe this may result in electric shock, injury, or fire.

[Disposal]

- Dispose of the motor as general industrial waste.

[Installation location and inspection/maintenance]

- Insulation deterioration of the motor may cause electric leakage, electric shock, or fire.
To ensure the service life and prevent damage to the equipment, provide adequate ventilation and maintain an ambient temperature between -15°C and 40°C. Ensure that the installation environment is free from dust, corrosive or explosive gases, salt, moisture, and dew condensation. For indoor installations, protect the pump from rain, wind, and direct sunlight.
- Regularly inspect and maintain each component to maintain optimal performance.
- If the motor is used for more than 40000 hours, it may cause ignition or other accidents due to aging deterioration.

Contents

	Page
1.Type and structure	5
2.Installation and operation	5
3.Daily Attention and Maintenance	8
4.Pump Performance	10
5.Troubleshooting.....	13
6.Names of each part	15

Quality Assurance Period and Scope

- As a rule, TERAL INC. will provide free-of-charge repairs for any defects for which we are responsible, for one year from the date of product delivery.
- The product warranty applies only to the delivered product unit.

1.Type and structure

Table 1. Types and structures

	Classification	Structure
Self-priming type	VKN	The motor and pump are integrated into a single unit, which is a common three-phase "coolant pump" that can be set on any frame. Mechanical seal is used for sealing.
Immersion type	VKP	The motor and pump sections share a coaxial configuration but are structurally separated. The pump section is designed to be submerged below the oil level during operation. Since no mechanical seal is used, it is suitable for machines in which the sealing part easily wears due to the contamination of oil by abrasive powder, cutting chips. A fringer is installed on the motor side to prevent the entry of oil.

2.Installation and operation

(1) Installation

VKN type	1)Install the pump as close to the oil surface as possible. 2)Oil may leak from the drain hole from the initial stage of installation. Therefore, oil-proofing and proper waste oil disposal measures should be taken. 3)Do not install the pump below the oil level, at an angle or in a horizontal orientation.
VKP type	The pump section must always be immersed in the oil. Control the oil level so that tank oil level is between the maximum oil level and the minimum oil level indicated in the outline drawing.

The coolant pump is specially painted in response to the alkaline cutting oils that have been used most recently.

The motor is totally enclosed or totally enclosed fan-cooled type, but it is not waterproof. During installation, ensure that it is protected from exposure to large amounts of water or oil.

Although there are four mounting holes to allow for flexible installation, securing the pump at tow diagonal positions is sufficient for actual mounting.

(2) Piping

Select and connect pipes to the discharge port (OUT) and suction port (IN) according to Table 2.

For VKN type, pump performance may deteriorate if there is air leakage at the suction side. To ensure air tightness, apply sealing tape or sealing agent to the connecting part and tighten it securely. Refer to the catalogue or technical data and make sure that piping length is not too long.

Table 2. Pipe Table

Output	Pipe Dimensions	Thread dimensions	Pump mounting bolt
20, 40	Gas pipe 1/4B	Rp1/4 thread (pipe thread)	M6(2 points)
60, 100	Gas pipe 3/8B	Rp3/8 thread (pipe thread)	M6(2 points)
180	Gas pipe 1/2B	Rp1/2 screw (pipe thread)	M8(2 points)
250	Gas pipe 3/4B	Rp3/4 screw (pipe thread)	M8 (2 points)
400, 750	Gas pipe 1B	Rp 1 thread (pipe thread)	M8 (2 points)

(3) Oil tank

Use a tank that has at least two partitions that allows oil to return to the suction inlet. Make sure that cutting chips and other debris do not enter the tank. If there is a lot of air bubbles, pump performance may decrease. Therefore, fill the tank with oil slowly and carefully so that the air does not enter.

If a large amount of foreign matter, such as slurry, enters the tank, it may cause wear or other problems.

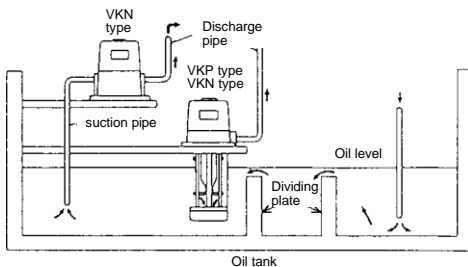

Figure 1. Installation

(4) Connection with power supply

The orientation of the terminal box on the coolant pump can be changed to face left or right.

Securely tighten the connection of the power cable and motor lead wires so that the terminals are not loosened. If the terminal becomes loose and contact is impaired, the motor may operate in a single-phase condition, which can result in burnout.

To prevent cutting chips, fluids, and other substances from entering the terminal box, provide adequate dustproof and drip-proof protection using connectors, cable glands, and similar sealing components.

Connect terminal securely to the power supply as shown in the figure below.

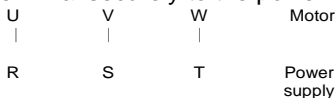

(5) Protection

Install switches and fuses according to the regulations of the power company.

When using a commercially available switch, be sure to insert a fuse with a capacitance 3 to 4 times the current listed on the name plate. If viscosity of the lubricant used is too high or the motor is restricted due to phase loss operation or foreign matter entering pump, the motor may burn out. If this is the case, we recommend using electromagnetic switch to protect against overload and to start the motor. Use the maximum allowable current listed in the catalogue and nameplate when setting the thermal relay current. A grounding terminal is provided in the terminal box, so please use it.

(6) Voltage

Please note that the expected pump performance cannot be obtained if voltage drop is remarkable. The motor torque is decreased in proportion to the square of the voltage drop, resulting in a reduced discharge rate and increased current. Be aware that sometimes the motor may be burnt out. Note that a thermal relay may trip if there is voltage unbalance in the three phases.

(7) Rotation direction

The rotation direction is indicated by arrows on the top of the frame, the main nameplate, or the external fan cover. If the rotation is reversed, interchange any two of the three terminal wires. (The standard rotation direction is clockwise.)

(8) Nominal oil

For VKN type (self-priming type), a nominal oil is required for the first operation after installation. The nominal oil is supplied from the discharge port to fill pump chamber and suction piping line. Connecting a T-shape fitting to piping at the discharge end is convenient for lubrication. Please note that if the pump is operated dry for more than 30 seconds during installation or after a long period of shutdown without priming oil, the mechanical seal may run dry and become damaged.

(9) Oil amount adjustment

Centrifugal volute pump with cock and sluice valve for easy adjustment of oil flow at the discharge end.

(The stop valve is not recommended because of its large resistance.)

(10) Liquid used

The pump performance values are based on tests conducted using freshwater. However, it cannot be used with water due to the risk of rust. Do not use the pump with any cutting fluid other than that specified in JIS K2241.

(11) Precautions for inverter drive

Rotating the motor above 60Hz may overload the motor. Please ensure overcurrent protection is applied at or below the maximum allowable current even at 60Hz or less.

The minimum frequency should be 20Hz. (Consult us separately for operation under 20Hz.)

For different voltage (400V class), contact your nearest sales office of TERAL INC. Protective measures against inverter surges may be required.

When the motor is driven by inverter, magnetic noise is generated, which can be more noticeable compared to operation with a commercial power supply. This magnetic noise does not adversely affect the motor quality, but depending on inverter, the tone can be adjusted by changing the carrier frequency. However, if the carrier frequency is changed, inverter output may drop, so be careful when selecting inverter.

If resonance occurs between pump and motor during normal operation, do not use them within that rotational speed range.

3. Daily Attention and Maintenance

(1) Temperature rise

During operation, the motor temperature rises, but it stabilizes within 2 to 3 hours after startup. The coil section of the motor is particularly critical in terms of temperature. However, by employing Class B insulation, the coolant pump can be used in the following range.

$$[\text{Ambient temperature}] + [\text{Temperature rise}] = 120^{\circ}\text{C}.$$

If ambient temperature exceeds 40°C, contact the manufacturer.

(2) Replacement of mechanical seal

The VKN type uses a long-life mechanical seal, so the pump can be used safely. However, it may be damaged by the intrusion of abrasive powder, cutting powder, etc. If oil leaks from the drain hole, mechanical seal may be worn or damaged, or cutting powder may have entered the sealing end face of mechanical seal, resulting in loss of sealing function. In such cases, please replace mechanical seal.

[Mechanical seal type]
EA560-013 (Dimensions 13 × 26 × 24)

Follow the procedures in Table 3 to replace the mechanical seal.

Table3. Mechanical seal replacement procedure

Disassemble according to the procedures 1 to 9 in the table and assemble in the reverse order. Be careful not to damage the sliding surface of the new mechanical seal. Applying turbine oil, etc. to the sliding surface will make assembly easier and will help prevent rusting.

Refer to Section 6 for the part numbers in the table.

Item	Remarks
1. Remove the end cover ⑬.	
2. Remove the shaft end screw (right thread) ⑲ and pull out the impeller ⑩.	
3. Remove the external fan cover ⑭. Remove the external fan retaining screw and pull the external fan ① off the shaft.	VKN (output 0.4kW - 0.75kW)
4. Remove the frame and bracket mounting screws. (2 places at 180°C degrees symmetrical)	
5. Remove the frame ⑥ from the bracket ⑩.	Lightly tap off with a wooden hammer.
6. Remove the bearing retainer mounting screws and remove the bearing retainer ⑦.	When assembling, tighten the mounting screws gradually and evenly.
7. Pull the rotor ④ off the bracket ⑩.	
8. Remove the rotary ring of the mechanical seal ⑨ attached to the shaft ⑱.	During assembly, shaft must be lubricated with 32 turbine oil. The rotating collar must be attached to the retaining collar (brackets) within one minute after installation.
9. Pull the retaining ring of the mechanical seal ⑨ off from the bracket ⑩.	Push out from the pump chamber side.

(3) Replacement of ball bearings

The motor section uses shielded ball bearings filled with high-performance grease, ensuring excellent lubrication performance and long service life without concerns about foreign matter entering the bearings or grease leakage.

If abnormalities occur due to the life of the ball bearings, replace them with new ones according to Table 4.

Table 4. Ball bearing type

Please refer to the Appendix. 1.

Disassemble the replacement according to the "Mechanical seal replacement procedure" in Table 3. Remove the rotary ring of mechanical seal in Item 8 of Table 3. Carefully remove the bearings from the rotor with a puller tool, taking care to avoid twisting. Since shaft of VKP type is particularly long, applying force to shaft end may cause deformation. Therefore, remove them by applying force to the stepped portion near the bearing position.

For installation, press the bearing in quietly to avoid twisting, either by using a suitable pipe against the inner ring of the bearing or by heating the bearing with a heater or furnace (ensuring the temperature does not exceed 100°C) before insertion."

Assemble the upper CX bearings by applying grease between the two O-rings on the outer diameter.

Shaft end is a critical part that prevents the impeller from rotating and maintains perpendicularity to the shaft. Please take care during disassembly and reassembly to avoid applying impact or causing scratches or damage to this area.

(4) Precautions for fixing impeller

The shaft end face and impeller mounting part affect impeller mounting strength and assembly precision. Sufficiently clean before installation. Tighten the mounting screws with the following tightening torque.

[320 N for M5 thread · cm, 560 N cm for M6 thread]

(5) Precautions for burning accidents

If the viscosity of the oil used is too high or if foreign matter enters the pump and restricts the rotor, the motor may become overloaded and could burn out. Single-phase operation or voltage drop may also cause burnout.

The motor burnout may also occur if the air surrounding the pump is not properly exchanged with outside air, causing the ambient temperature to rise excessively. Please ensure adequate ventilation.

If the discharge stops or drops suddenly, turn the switch off and check for foreign matter in the pump.

For VKN type, if the shut-off operation is performed for a long time, frictional heat of impeller and mechanical seal may accumulate in the pump chamber, potentially causing the temperature to exceed the allowable limit. Please ensure that shut-off operation does not exceed 30 minutes. When the pump is intended to run continuously regardless of whether oil is being discharged, install a separate branch (bypass) circuit with narrow piping to ensure that a small amount of oil continues to flow.

(6) Drain hole

A drain hole is provided on the side of the bracket. This hole is used to protect the bottom shielded ball bearing if oil enters the motor from the pump side. If oil leaks from this hole during operation, stop the pump immediately and carry out an inspection.

VKN type: High possibility of mechanical seal malfunction

VKP type: High possibility that the oil level in the tank is above the specified value.

The drain hole also serves to release any moisture that may accumulate within the motor as a result of breathing mechanism.

(7) Daily maintenance

No special maintenance is required other than regular monitoring of operating conditions. However, if dust accumulates on the outer surface of the motor, the cooling efficiency may deteriorate. Periodically clean this area.

Periodically clean the oil tank and replace the oil to prevent foreign matter from entering the oil.

(8) Consumable parts replacement period

Refer to Table 5 for consumable parts and their replacement period.

Table 5. Consumable parts replacement period

Part name	Model	Replacement period
Ball bearings	All models	Approx. 10000 hours
Mechanical seal	VKN type	Approx. 5000 hours
O-ring	VKN type	When disassembled (approx. 5000 hours)
Fringer	VKP type	When disassembled (approx. 10000 hours)
Impeller	All models	When worn

(Note)1. The values in this table are approximate and are not guaranteed.

2.If the head or threads of the screws are damaged or striped, replace them as necessary.

3.The rubber parts such as mechanical seal, O-ring and fringer will deteriorate over time even if the pump is not operated. Replace them every three years.

(9) Maintenance of stator coil

The service life of stator coil varies greatly depending on the usage conditions. When replacing mechanical seal or bearings, it is recommended to clean and dry the motor windings to maintain optimal cleanliness.

4.Pump Performance

Refer to the characteristic diagram in the catalogue for the pump performance. The values shown on the Nameplate indicates discharge rate by freshwater.

Note that the discharge rate will vary significantly under the following conditions.

(1) Frictional Loss of piping

The discharge rate is determined by subtracting the head loss caused by piping, fittings, and other components from the "discharge rate-Total head" curve. The piping head loss is not constant and is influenced by factor such as internal surface smoothness, flow rate and viscosity. Figures 2 and 3 provide

examples of head loss calculation for smooth piping.

Use as few joints and bends (elbow, etc.) in the piping. Avoid piping where the cross-sectional area suddenly changes.

(2) Oil viscosity and pump performance

As viscosity of the oil increases, the motor load increases and the discharge rate decreases. Although the discharge rate decreases, the pump is designed to operate with oil viscosity up to the levels shown below.

Table5. Available viscosity Unit: mm²/s(= cSt)

Model	50Hz	60Hz
VKN (Self-priming flow rate design)	150	75
VKN-H (Self-priming pressure type)	32	
VKP (Immersion flow rate type)	150	75
VKP-H (Immersion pressure type)	32	

Since oil viscosity varies significantly with temperature, special attention should be paid during winter. As the oil temperature drops, its viscosity increases, resulting in the motor load. Consult TERAL INC. especially when using oils with higher viscosity.

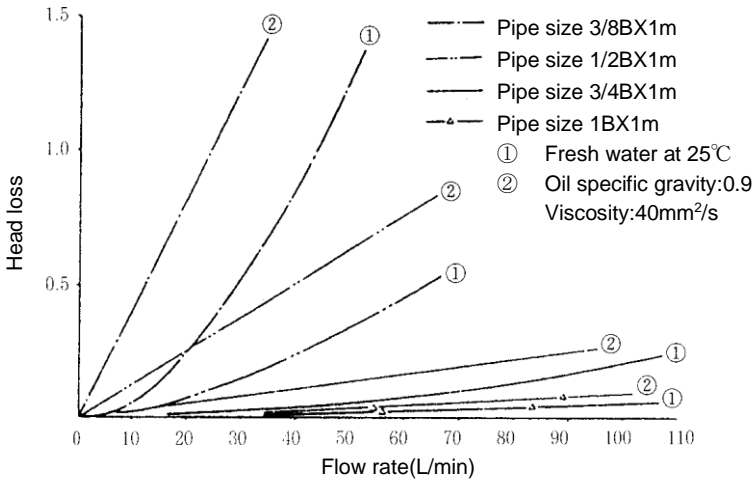

Fig. 2 Pipe friction head loss

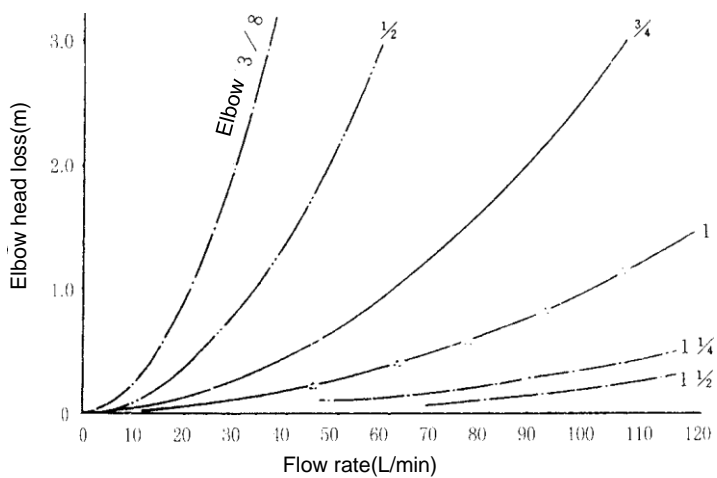

Fig. 3. Elbow head loss (per elbow)

5.Troubleshooting

Table 6. Troubleshooting

Phenomenon		Cause	Countermeasures
The motor does not rotate.	Motor makes humming/ buzzing sound.	The switch contact is defective.	Adjust or replace the contact section.
		The fuse is blown.	Replace the fuse.
		One phase of the cable is broken.	Replace the cable.
		The stator(motor) coil is has a broken wire.	Have a specialist repair
		The rotor and stator are contacting due to bearing wear.	Have a specialist repair.
	No sound during operation.	The stator (motor) coil has a broken wire	Have a specialist repair.
		Power failure	Contact the power company.
		The connection cable has a broken wire.	Replace the cable.
The switch contact is defective.		Adjust or replace the contact section.	
The motor rotates.	Motor makes humming/ buzzing sound. Excessive current	The rotor and stator are contacting.	Have a specialist repair.
		The rotor-stator gap is unbalanced.	
		One phase of the stator (motor) is short-circuited.	
	The discharge rate is low or there is no output.	The motor is rotating in reverse.	Two out of three terminal are interchanged.
		There are many bubbles in the oil tank.	Remove the cause of foaming.
		The impeller is worn or damaged.	Have a specialist repair.
		The backflow of oil in the piping compresses the air inside the pump, forcing it downward and causing the impeller to become exposed to air.	Discharge of compressed air (e.g. bypass circuit-edge) Drain all oil from piping Reduce the difference of elevation in the piping.
		Air is leaking in the suction side piping. (VKN)	Repair the piping.
		The liquid level is too low.	Raise the liquid level.

Sudden fluctuation in discharge rate	Mechanical seal wear (VKN)	Replacement of mechanical seal
	Foreign matter has entered the pump.	Inspect and clean the pump.
	Disconnected or damaged piping	Repair or replace the piping.
Liquid leakage from drain hole	Mechanical seal wear (VKN)	Replace the mechanical seal.
	Liquid level too high or bubbles in the tank (VKP)	Lower the liquid level. Remove the cause of the bubbles.
Thermal trip	Viscosity is too high.	Use a low-viscosity liquid.
	Significant voltage drop or unbalanced voltage	Inspect the power source.
	Foreign matter caught inside the pump	Inspect the inside of the pump.

6.Names of each part

VKN type

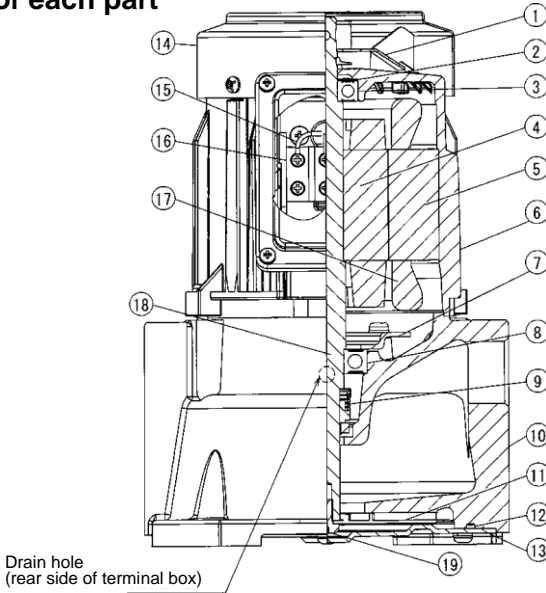

VKP type

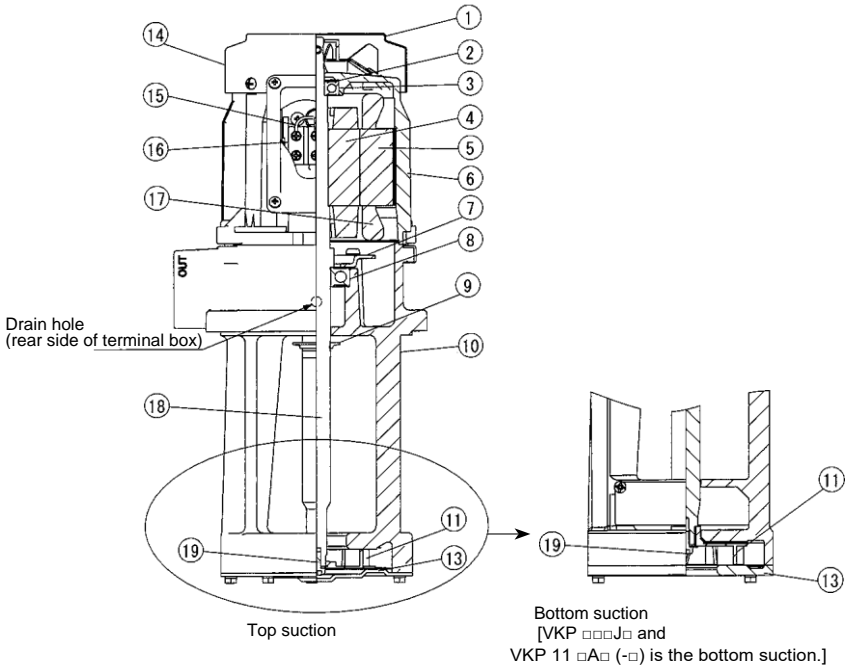

Table 7.Parts list

Part No.	Part name	
	VKN type	VKP type
* 1	External fan	
2	Preload spring	
3	Unload side shielded ball bearing	
4	Rotor	
5	Stator core	
6	Frame	
7	Bearing retainer	
8	Load side shielded ball bearing	
9	Mechanical seal	Fringer
10	Bracket	Middle bracket (output 750W)
11	Impeller	
12	O-ring	No applicable number
13	End cover	
* 14	External fan cover	
15	Lead wire	
16	Terminal box	
17	Stator coil	
18	Shaft	
19	Impeller mounting screw	

Caution 1. The asterisk (*) indicates that the part is mounted on 400W, 750W.
 2. Part No.19 impeller mounting screw is a right-hand screw.

Appendix 1. Ball Bearing list

Type	Output (kW)	Bearing	
		Load side	Unload side
VKN	0.04	6202ZZ	6200CXZZ
	0.06 - 0.4	6203ZZ	6201CXZZ
			6203CXZZ
VKP-AT	0.02 - 0.04	6200ZZ	6200CXZZ
	0.06 - 0.25	6203ZZ	6201CXZZ
		6204ZZ	
	0.75	6004ZZ	6203CXZZ
VKP-AHT	0.18	6204ZZ	6201CXZZ
VKP-AFT	0.25	6203ZZ	
	0.4	6204ZZ	
VKP-AKT	0.18 - 0.4	6206ZZ	
VKP-HT	0.06 - 0.4	6203ZZ	
VKP-JT	0.18 - 0.25	6004ZZ	
	0.4	6204ZZ	

TERAL
TERAL INC.

Head Office

230, Moriwake, Miyuki-cho, Fukuyama-city, Hiroshima, 720-0003, Japan
Tel.+81-84-955-1111 Fax.+81-84-955-5777

www.teral.net