

Coolant Pumps General Catalog









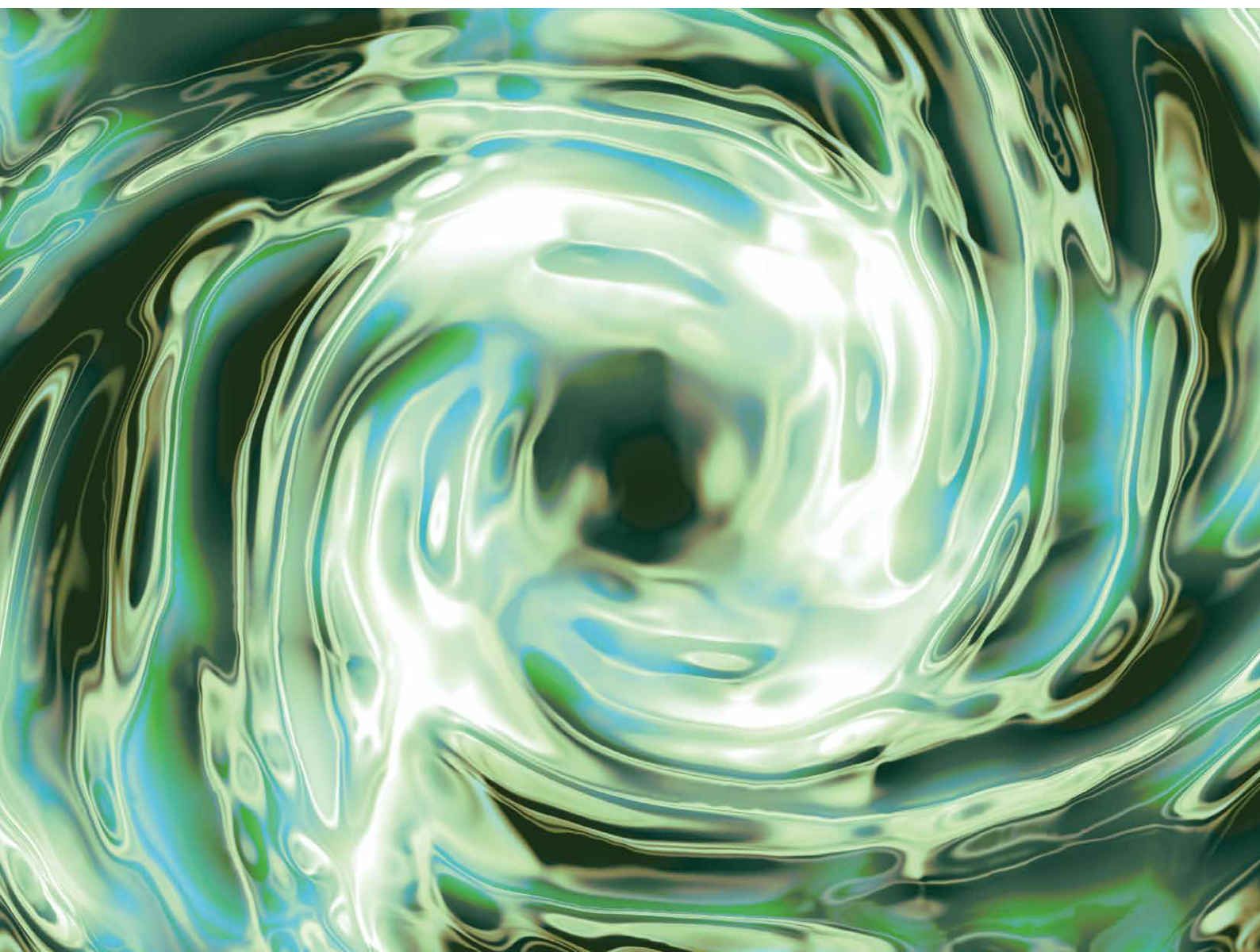





TERAL



TERAL: Maximizing Effectiveness

50Hz/60Hz



Document for selection		Usage and Table of General Specification	General Concept Chart for Use in Selecting Products	Features	How to choose pumps	Handling precautions Notes on ordering
		P.3	P.4	P.6	P.8	P.9
Installation type	Flow rate Head	Low flow rate	Medium flow rate	High flow rate		
Immersion type (Non-self-priming)	Low head	VKP P.12 				
		LFE P.20 				
	Medium head	LHW P.22 				
		LFO ※Available for dirty liquid P.24 				
		LBK P.29 				
	High head	LKWE / LPW ※Available for dirty liquid P.40 P.46 				
		LKW P.56 	VKB P.60 			
Floor type (Self-priming)	Low head	VKN P.111 				
	Medium head	LPSE / LPS ※Available for dirty liquid P.117 P.122 				
Immersion type (For cleaning inside tanks)	Low head	SKM P.126 	※Available for dirty liquid These are the pumps to use after the primary process through mesh cage, chip conveyor, or magnet separator, etc.		The frame for each unit type is colored by the material of the impeller  Stainless steel (SUS304)  Cast iron (FC, FCD)  Others (Resin, CAC407)	

Usage

- Circulation and transfer of coolant for machine tools
For internal environment of machine tools such as spindle, drill, end mill, etc., or transfer
- Circulation and transfer of cleaning liquid
For washing work, jig, bed, inside of the machine, etc.
For shower washing and splash gun
- For various filtration
- For pumping from the tank
- Other purposes

Table of General Specification

Installation type	Priming method	Dirty liquid	Sealing structure	Model	Stage	Immersion type: Immersion depth ^{※1} Floor type: maximum suction lift	Material			Frequency (Hz)	Representative discharge rate ^{※2} (L/min)	Max. head ^{※2} (m)	Output ^{※1} (kW)	Allowable kinematic viscosity (mm ² /s)	Poles (P)	CE marking		
							Impeller	Discharge casing	Intermediate casing guide vane									
Immersion type	Non-self-priming	—	Non-seal	VKP	Single	130-350mm	SUS304	FC150	—	50	13-142	7	0.02-0.75	150	2	○		
										60	18-190	7	0.02-0.75	75	2			
		—	Non-seal	VKP-H	Single	145-280mm	SUS304	FC150	—	50	10-20	11.5	0.06-0.4	32	2	○		
										60	10-20	16.5	0.06-0.4		2			
		—	Non-seal	LHW	Multiple	200mm	Resin	FC200	Resin	50	20-80	50	0.75-1.1	1	2			
										60	20-90	73	0.75-1.1		2			
		—	Non-seal	LBK	2	Multiple	153-297mm	SUS304	FC200	SUS304	50	25-42	66	0.35-1.8	75	2	○	
											60	30-50	88.9	0.55-2.2		2		
											50	85	32.9	0.35-1.8		2		○
											60	100	47.6	0.55-2.2		2		
		—	Non-seal	LFE	Single	300mm	FCD450	FC200	—	60	60-430	8	0.25-0.75	1	2			
										50	100-750	24	0.75-5.5	A:32 B:150	2			
		60	100-900	36	0.75-5.5	2												
		Available	Non-seal	LFO	Single	350/500mm	FCD450	FC200	—	50	50-400	40	0.75-3.0	A:32 B:150	2	○		
										60	50-450	56.4	0.75-3.0		2			
		Available	Non-seal	LPWE	Multiple	270-402mm	FCD450	FC200	FC200	50	200-700	63	1.5-7.5	40C:32 40D:150 50A/65A:1	2			
										60	60-750	64	0.75-7.5		2			
		—	Non-seal	LPW	Multiple	255-330mm	FCD450	FC200	FC200	50	20-70	400	2.0-4.0×2	1	2			
										60	20-70	400	2.0-4.0×2		2			
		—	Non-seal	LKW	Multiple	330(Single)mm	Resin	FC200	Resin (+SUS304)	50	40	114	0.4-2.6	37.5or75 ^{※1} FH/FQ:1	2	○		
60	50									152	0.68-3.57	2						
—	Non-seal	VKB	H	Multiple	300-616mm	SUS304	FC200	SUS304	50	85	78	0.54-3.96	1	2	○			
									60	100	108	0.9-3.6		2				
—	Non-seal	LVS	Multiple	196-979mm	SUS304	FC200	SUS304	50	10-500	230	0.75-18.5	1	2	○				
								60	10-600	260	0.75-18.5		2					
—	Non-seal	LVSS	Multiple	196-979mm	SUS304	SCS13	SUS304	50	10-500	230	0.75-18.5	1	2	○				
								60	10-600	260	0.75-18.5		2					
Floor type	Self-priming	—	Mechanical seal	VKN	Single	-0.7m	SUS304	FC150	—	50	13-140	7	0.04-0.75	150	2	○		
										60	16-190	7	0.04-0.75	75	2			
		—	Mechanical seal	VKN-H	Single	-0.7m	SUS304	FC150	—	50	10-20	10.5	0.06-0.4	32	2	○		
										60	10-20	16	0.06-0.4		2			
		Available	Non-seal	LPSE	Multiple	-0.7m	FCD450	FC200	FC200	50	50-350	38.7	0.75-3.0	A:32 B:150	2	○		
										60	50-400	34	0.75-3.0		2			
		Available	Non-seal	LPS	Multiple	-0.7m	FCD450	FC200	FC200	50	250-650	62	5.5-7.5	1	2			
										60	250-700	56	5.5-7.5		2			
Immersion type	Non-self-priming	—	Non-seal	SKM	Single	257mm	SUS304	FC150	—	50	50	6	0.25	1	2			
										60	50	9	0.25		2			

※1 : The value depends on the type. Please refer to the specification table of each unit type.

※2 : The value is a typical performance value. Please refer to selection chart and specification table for detailed performance of each model.

50Hz

Immersion type

Figures in the selection chart are colored by the material of impellers.

- Stainless steel (SUS304)
- Cast iron (FC, FCD)
- Others (Resin, CAC407)

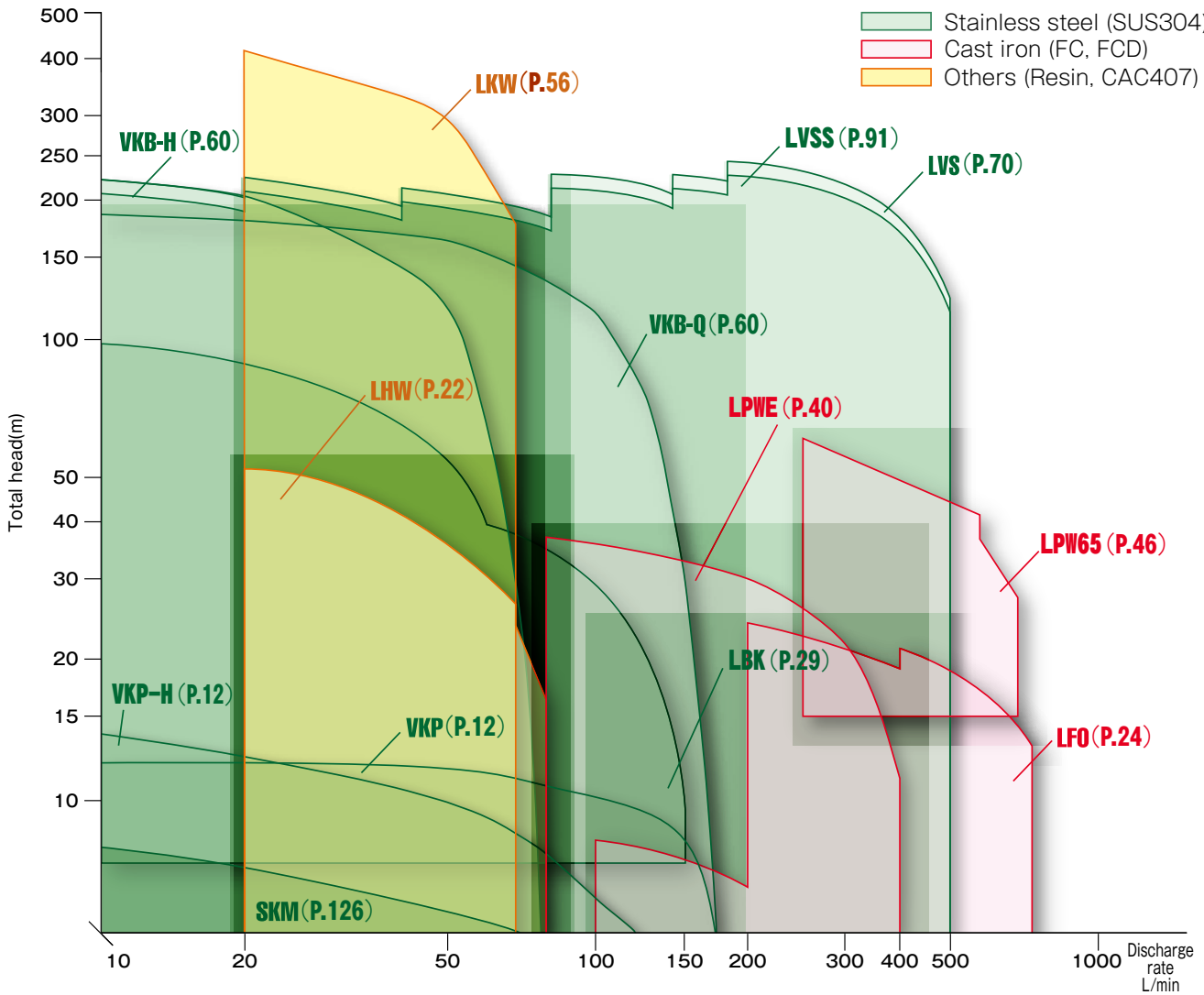

Floor type (Self-priming)

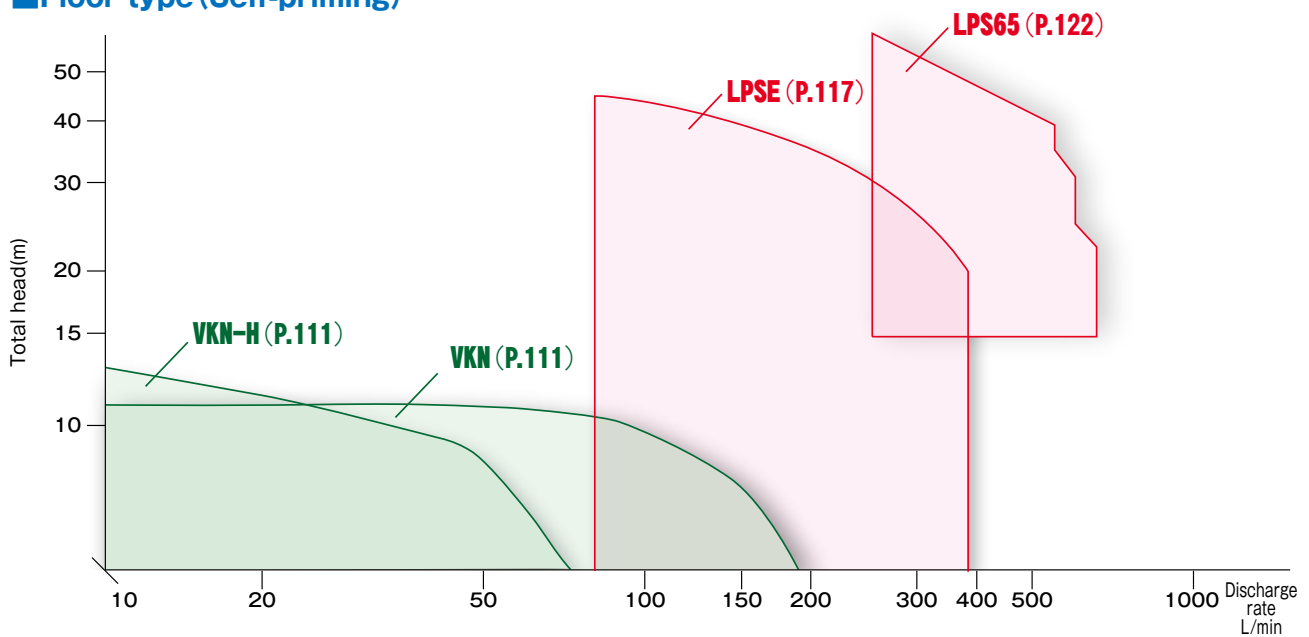

Please refer to the page of each unit type for the choices.

60Hz

Immersion type

Figures in the selection chart are colored by the material of impellers.

- █ Stainless steel (SUS304)
- █ Cast iron (FC, FCD)
- █ Others (Resin, CAC407)

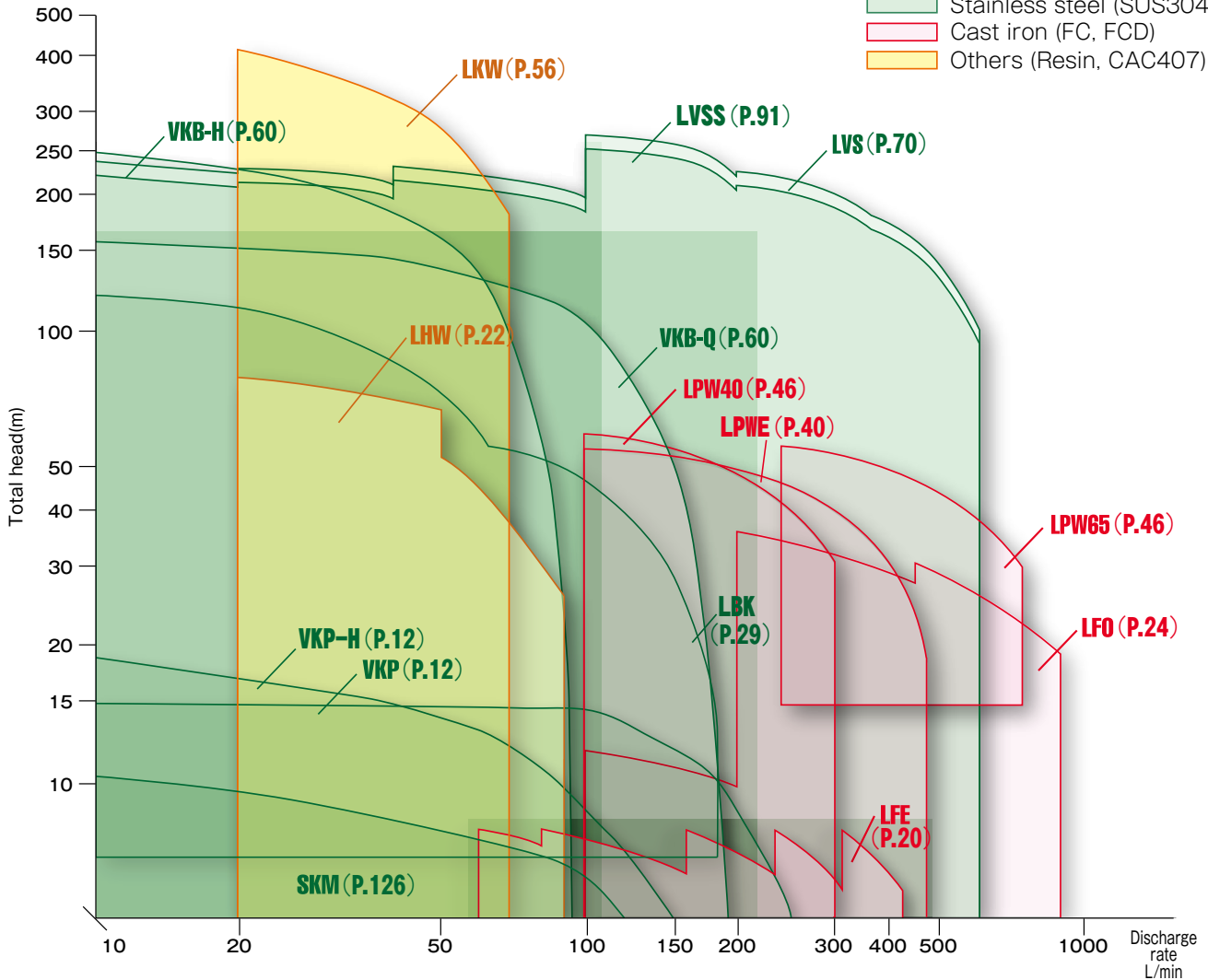

Floor type (Self-priming)

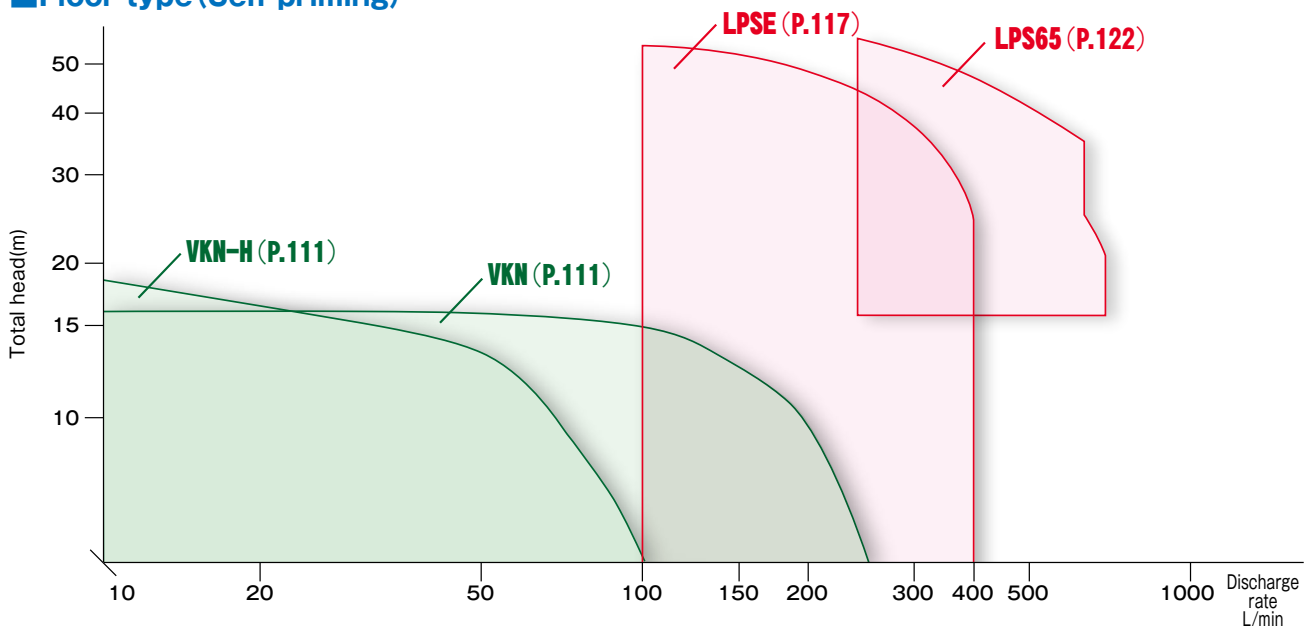

Please refer to the page of each unit type for the choices.

TERAL Coolant Pump

We have continued improvements reflecting our longtime experience and customers' opinions.

Wide variation

● Installation method

Immersion type

VKP LFO LPWE etc...

Floor type (Self-priming)

VKN LPSE etc...

For cleaning inside tanks

SKM

● Shaft seal structure

Mechanical seal type (VKN) It is highly efficient because there is no leak in the shaft seal.

Non-seal (mechanical seal-less) type ·Resistant to sludge, they are usable for dirty liquid (some types).
·There are other features including following:

TERAL' s original non-seal structure allows coolant to flow from a narrow clearance without using a seal between the pump section and the motor section.

Many advantages that only non-seal pumps can provide

- 1 No coolant leakage or other problems.**
Helps cut down running costs.
- 2 Prevents air accumulation.**
Reduces initial trouble.
- 3 Capable of serial running (LKW-D model)**
A series of volute pumps can generate up to 3.92MPa
- 4 Not easily affected by small quantity of liquid or shut-off operation.**
Build the pump system you want.
- 5 Not easily affected by chips**
Can be used for dirty coolants. (some types)

※What is non-seal structure?
This structure inwardly releases coolant by depressurizing through a narrow clearance without the use of a mechanical seal.

●Others

[Material of the impeller and casing] Stainless steel, cast iron, resin, etc.	[Performance] Low - high flow rate, low - high head	[Length of the immersion part] There are alternatives (some types)
---	---	--

You can make a choice according to the various uses.

High Durability, Abrasion Resistant

●High Efficiency is realized with 3-dimensional fluid analysis & structural analysis (LVS-e)

- Energy conserving by enhancing the efficiency of pumps
- Life cycle cost saving by non-seal structure



Example of fluid analysis in impellers

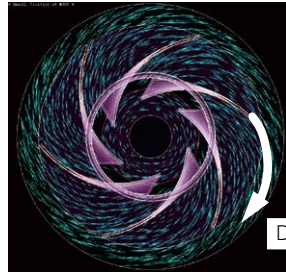

The flow of the fluid in the impeller is simulated with computers to optimize the shape of the impellers. Each line in the figure shows the flow of the fluid.

Direction of the flow

●High durability is demonstrated with our reliability test (VKB)

- Reduction of characteristic value is within 10%
- No leak, no abnormal vibration or sound.
- No abnormal abrasion of parts

※Validated with the operation test (accelerated life test) of 2 years (about 17,500 hours, switching on/off 4.2 million times)







A tank containing sludge (slurry content is about 10wt%)



Scene of the testing

※It is the result of the internal test. Durable life of pumps and their parts differ by liquid and operation circumstances.

List of obtained certifications

Model	USA 	CANADA 	EU 	CHINA 	KOREA 
	UL&NEMA Premium	CSA	CE/RoHS	GB3	KC
VKP	○	○	○	○	
LFO				○	
LBK	○	○	○	○	○
LPWE			○	○	
LPW	○				
VKB			○	○	
LVS	○	○	○	○	○
LVSS	○	○	○		○
VKN	○	○	○	○	
LPSE			○	○	

Pumps are very influenced by the state of their piping (piping length, kinds of coupling joints, their numbers, etc.). Therefore please make the piping as short as possible, and make bends, such as elbows, joints, and valves as few as possible. When you select pumps, specifications including usage, processed liquid, flow rate, and total lifespan need to be fully considered. Calculation of the total head is shown below. Please use it as a reference.

● How to calculate Total Head

Figure 1

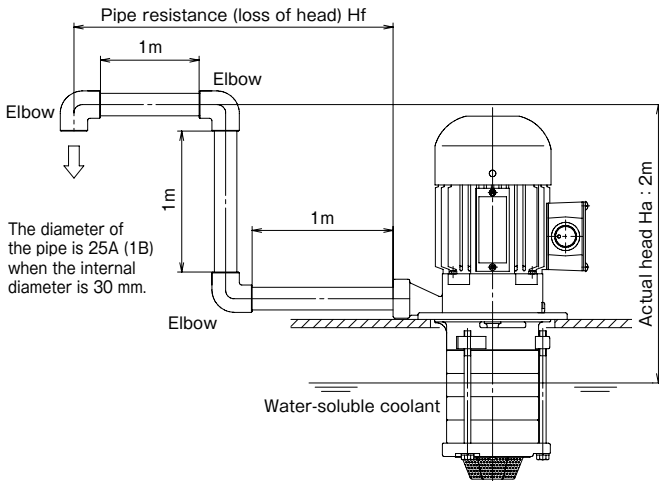

Necessary total head is calculated assuming the flow rate of 50 L/min in the piping state shown in Figure 1.

Total head is computed as follows:
 Total Head $H_t[m] = \text{Actual Head } H_a[m] + \text{Loss of Head } H_f[m]$

In the case shown in Figure 1:
 Actual head H_a : **2 m**, Loss of Head H_f : **0.79 m** *1
 From the above formula,
 Total head is **2 m + 0.79 m = 2.79 m**.

Therefore, pumps that satisfy total head 2.79 m or above should be selected. (Figure 2)

[Note]
 The above calculation is for a case of water-soluble coolant (kinematic viscosity 1 mm²/s). There are some cases that the loss of head is very different, depending on type and viscosity of liquid used, piping conditions, etc.

Figure 2 Pump characteristic curve

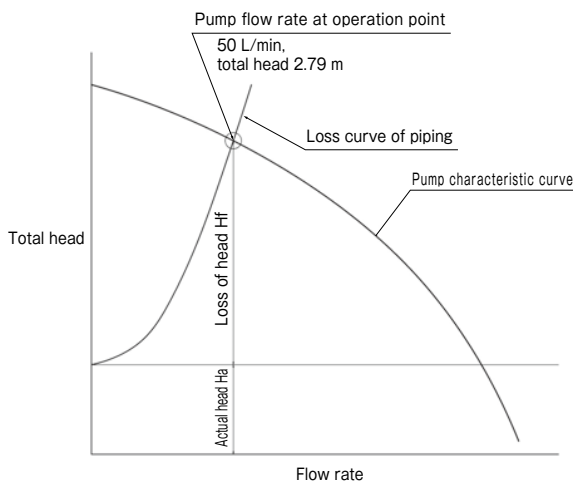

※1 How to compute loss of head

Loss of head is calculated as follows:
 Loss of head $H_f[m] = f \times (L/d) \times V^2/2g [m]$
 L: equivalent length of straight pipes [m] V: flow velocity [m/s]
 d: internal diameter of the pipe [m] g: gravitational acceleration 9.8 [m/s²]
 f: coefficient of loss

In the case shown in Figure 1:
 Equivalent length of straight pipes, L: **11.1 m** *2
 Flow velocity, V: **1.18 m/s**
 Internal diameter of the pipe, d: **0.03 m**
 From the above formula,
 Loss of head $H_f = 0.03 \times (11.1/0.03) \times 1.18^2 / (2 \times 9.8) = 0.79 m$

[Note]
 Coefficient of loss is the value assuming that the aqueous solution is 0.03. Please note that the coefficient differs greatly for oily liquids.

Table 1 Table of approximate equivalent length of straight pipes for elbows, etc. [m]

Nominal diameter	Inlet part	Outlet part	90-degree elbow	Ball valve
8A (1/4B)	0.3	0.6	0.7	6.4
10A (3/8B)	0.4	0.8	0.9	6.7
15A (1/2B)	0.6	1.2	1.1	6.7
20A (3/4B)	0.8	1.6	1.3	7.3
25A (1B)	1.1	2.2	1.6	8.8
40A (1 1/2B)	1.9	3.2	2.3	12.8

※2 How to calculate equivalent length of straight pipes

"Equivalent length of straight pipes" is the measurement of loss generated by elbows, valves, etc., expressed by the length of a straight pipe with the same diameter causing the same amount of pressure loss.

In the case shown in Figure 1:
 Straight part: **1 m + 1 m + 1 m**
 Elbow: **1.6 m × 3 = 4.8 m**
 Inlet: **1.1 m**, outlet: **2.2 m**
 Equivalent length of straight pipes, L = **3 m + 4.8 m + 1.1 m + 2.2 m = 11.1 m**

[Note]
 Please refer to Table 1 for gross equivalent length of straight pipes of elbow, etc.

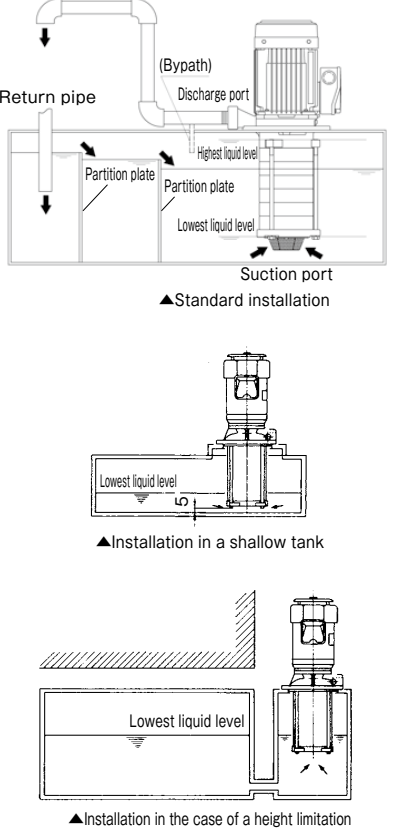
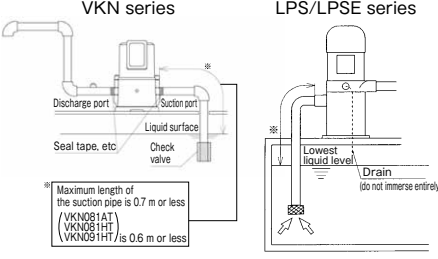
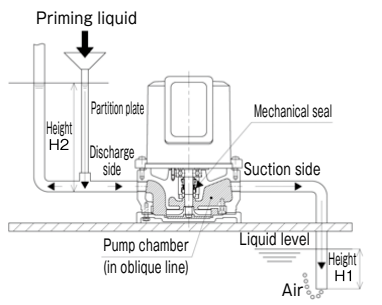
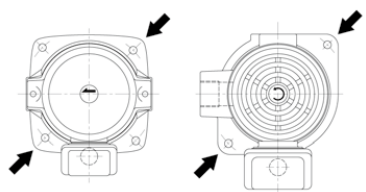
Item	Model	Content	
Installation	Immersion type	 <p>Return pipe (Bypass) Discharge port Partition plate Highest liquid level Lowest liquid level Suction port</p> <p>▲Standard installation</p> <p>▲Installation in a shallow tank</p> <p>▲Installation in the case of a height limitation</p>	<ul style="list-style-type: none"> ● Make the piping as short as possible, and make the corners like elbow, joints, and valves, etc., as few as possible. Additionally, please use pipes with standard diameter. Please note that sometimes discharge becomes low if the pipe is thin or there are many corners. ● Support the piping sufficiently so that the pump does not take the load of pipes. ● Do not screw pipes into pumps forcefully. Joint may be damaged. ● Roll on the screw thread of pipes with seal tape, etc., so that liquid or gas does not leak. Additionally, roll the seal tape securely so that the tape does not block the pipe. ● Tank (oil tank) should be as large as possible. <ul style="list-style-type: none"> ※Recommended capacity is 3 times as much as the quantity of discharge per minute. If the capacity is too small, there can be some faults, such as a rise in liquid temperature, early clogging of strainer with chip powder, etc., and the reduction of discharge caused by air bubbles. ※When the liquid is poured into pumps, pour calmly so that they do not catch air bubbles. ● Be careful that chip powder or dust does not enter inside the pumps. <ul style="list-style-type: none"> ※Filter the liquid with mesh cages, chip conveyors, magnet separators, etc., before pumping the liquid. The number of necessary processes differs by type. ● Take appropriate measures, such as setting up a bypass after the discharge outlet of the pump, if there can be a water hammer. ● If the liquid level is too low, discharge will be reduced or sometimes it becomes unable to lift liquid because of air inside. The liquid level shall be higher than the lowest liquid level shown in the assembly drawing. Note that the lowest liquid level differs by kinematic viscosity or the state of the surface. Please give a sufficient margin of height for safety. Additionally, if the liquid level is too high, liquid might enter inside the motor from the drain hole, consequently causing the motor to be out of order. Make the liquid level lower than the highest liquid level shown in the assembly drawing.
	Self-priming type	 <p>VKN series LPS/LPSE series</p> <p>Discharge port Suction port Liquid surface Seal tape, etc. Check valve Suction side Drain (do not immerse entirely)</p> <p>※ Maximum length of the suction pipe is 0.7 m or less (VKN081AT, VKN081HT, VKN091HT) / is 0.6 m or less</p>	<ul style="list-style-type: none"> ● Install them close to the tank (oil tank) so that the suction pipe may be as short as possible. Maximum length of the suction pipe shall be 0.7 m (0.6 m for VKN081AT, VKN081HT, VKN091HT) or less. If a suction pipe must be longer for some reason, install a check valve in the pipe on the suction side. Additionally, seal on the screw thread of the pipe with seal tape, etc., to avoid leak of liquid or air. Especially if there is an air leak, the flow rate will be reduced or it will run short of lift liquid.
Priming liquid	Self-priming type	 <p>Priming liquid Height H2 Partition plate Discharge side Mechanical seal Suction side Pump chamber (in oblique line) Liquid level Air Height H1</p>	<ul style="list-style-type: none"> ● In the first operation after the installation, or long after the last operation, the pump chamber (oblique line in the figure below) might be filled with air. Because of this, venting the air with priming liquid is necessary. Air in the pump chamber can cause the pump to suck insufficiently/have pump characteristics insufficiently exerted (short of flow rate or pressure). Additionally, if the pump is operated for long time in a state of insufficient capacity, it might damage the mechanical seal, etc. <p>[How to prime]</p> <p>VKN series</p> <ul style="list-style-type: none"> ● Priming liquid should be poured until the air in the pump chamber is entirely exhausted (until air stops bubbling from the tip of the suction pipe) from the discharge. If the height from the outlet to the inlet of the priming H2 is lower than the length of the suction pipe below the surface H1, priming may not sufficiently fill the pump. In this case, install an air vent in the suction pipe or make the inlet for the priming sufficiently high. <p>LPS/LPSE series</p> <ul style="list-style-type: none"> ● Pour the priming liquid in the priming inlet in the pump discharge until water comes out from the suction pipe.
Installation	VKN VKP	 <p>Mounting hole for VKN / VKP series Arrows point at the dimension in JEM standard.</p>	<ul style="list-style-type: none"> ● The VKN / VKP series have four mounting holes (excluding some types), but they are for enlarging the range of usage. Two diagonal holes are enough for actual mounting. (Two holes comply with the dimensions of the JEM standard, the other two holes are proprietary.)

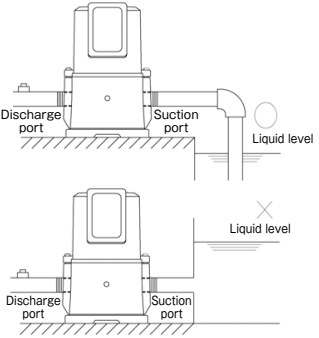
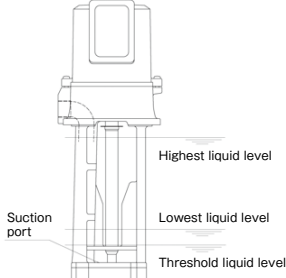
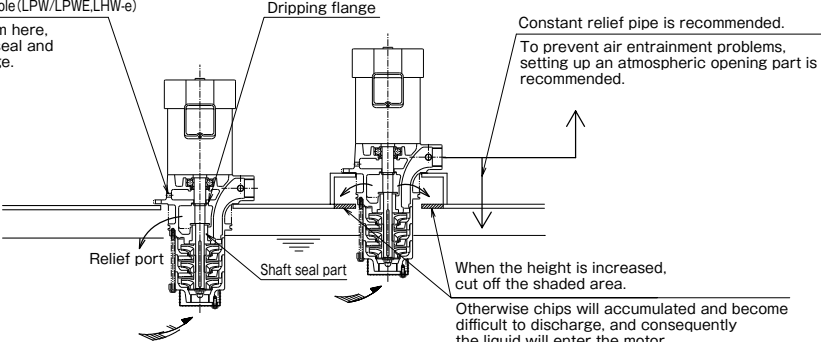
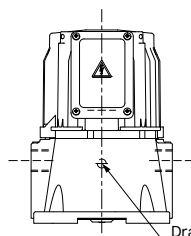
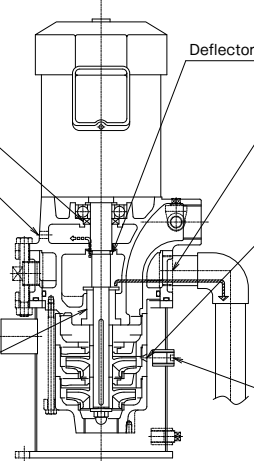
Item	Model	Content
Level of the liquid surface	VKN	 <p>● Make the liquid level of VKN series lower than the suction port of the pump. If the surface is higher than the suction inlet, liquid can leak from mechanical seal.</p>
	VKP	 <p>● Figures of upper suction type VKP series machines are shown at "lowest liquid level," "highest liquid level," and "threshold liquid level" in the outline drawing. "Lowest liquid level" It shows the range where the amount of discharge is about the same as the rated value, and there is no air biting. "Threshold liquid level" It shows the range where the amount of discharge becomes about half of the rated value and there is air biting. "Highest liquid level" Make it a distance from the pump flange surface by at least 20 mm.</p>
Prevention of problems for immersion type		 <p>Leakage detection hole (LPW/LPWE/LHW-e) If liquid leaks from here, check the shaft seal and the dripping flange.</p> <p>Constant relief pipe is recommended. To prevent air entrainment problems, setting up an atmospheric opening part is recommended.</p> <p>When the height is increased, cut off the shaded area. Otherwise chips will accumulated and become difficult to discharge, and consequently the liquid will enter the motor.</p>
Prevention of problems in the suction type	VKN	 <p>Drain A leak from the drain is caused by problems with the mechanical seal</p>
	LPS/LPSE	<p>LPS/LPSE series</p>  <p>Oil seal</p> <p>Leakage detection hole Liquid leak from the leakage detection hole indicates a failure in the drainage passage. If this hold is clogged, the inside of the motor might be immersed in the liquid.</p> <p>Shaft seal (sliding part) When the shaft seal (sliding part) is excessively deteriorated, the amount of leak increases and the liquid may leak from the leakage detection hole.</p> <p>Deflector</p> <p>Drain port If the drain port is clogged, liquid may leak from the leakage detection hole.</p> <p>Siphon prevention hole If the siphon prevention hole is clogged, the liquid is not retained inside the pump due to siphon effect when the pump is stopped, and the suction might be disabled when the pump is restarted.</p> <p>Cleaning port When the siphon prevention hole is clogged, remove the plug, inspect and clean the hole.</p> <p>Note) Although the structure of LPS65-e is different from the above figure, notes about shaft seal (sliding portion), drain port, siphon prevention hole, and cleaning connection are applicable.</p>

Item	Content
General	<ul style="list-style-type: none"> ● Before using (installing, carrying, maintaining, etc.) the product, be sure to read the manual thoroughly. Be sure to use the machine after completely understanding the information on machines, safety, and cautions. Appropriate handling in each step from beginning to actual operation, as well as maintenance after the initial operation, is necessary to make the most out of the coolant pump, preventing accidents, and continuing good operation for long time. ● Do not handle the machine when it is operating. Be sure to turn off the power before handing it. ● In the case of a power outage, be sure to turn off the power switch. ● If there is any problem, please stop operations and turn off the power switch. ● Bury the earth terminal securely. ● The piping and cable lining shall comply with electronic facility standards and internal line standards. ● A protection device is not included in the package. It is required by law to install an overcurrent protective device. It is highly recommended to install other protection devices (earth leakage circuit breaker, etc.). ● Take sufficient measures for dust proofing and dew proofing in order to prevent cut powder or coolant entering from lining hole into terminal box. Additionally, do not remove grommets from unused terminal holes. ● Note that motor might be burned or thermal relay might trip if the voltage is volatile. ● Do not use the products in an explosive atmosphere. ● Never place any combustibles near the product. ● We cannot produce machinery with increased safety or explosion proof. ● Volatile liquids, such as kerosene or gasoline, cannot be used. ● While operating, never touch or get close to rotating parts (external fan, impellers, etc.). ● Do not put any material or fingers into the aperture of the product (fan cover, discharge opening, suction opening, drain hole, etc.). ● Never climb the machinery. ● Products become considerably hot while operating. Do not touch with your hand or any part of the body. ● Do not restrict ventilation around the product. ● Put it in a convenient location for maintenance operation (avoid narrow spaces). ● Place it on a flat surface and anchor it so that it will not shake. ● Select a rigid surface to install the product on so that vibrations will not be amplified in operation. ● When it is run with inverters, the frequency shall not exceed 60 Hz. Avoid a frequency with which resonance occurs. Otherwise resonance may occur depending on installation conditions. ● If the kinematic viscosity of the liquid is too high, the life of the motors might be shortened, or burn out. Be sure to use the liquid within the threshold kinematic viscosity [mm²/s] shown in the specifications. ● They are designed as pumps for liquid containing fine powder or fine chips. But for the pumps using the mechanical seal (VKN), the life of the mechanical seal might be shortened if hard sludge, such as polishing powder, abrasive grain, or diamond powder, are contained in the liquid, the life of the mechanical seal might be shortened. Then install filters (magnetic filter or paper filter, etc.). Additionally, please note that special liquids, such as printing liquid or acid liquid cannot be used. Please inquire about other special liquids (e.g. ceramics). ● Check the direction of rotation before connecting the machine. ● For pumps with air fled valves, half open the valve and check if liquid is discharged when starting the operation. After it is confirmed, close the air fled valve securely. ● Because it is a centrifugal pump, flow rate can be adjusted by adjusting the valve on the discharge side. Additionally, the motor will not be overloaded even if the valve is closed. Since the temperature of the liquid becomes high if it is operated with the valve closed, keep some flow rate, or stop the pump if it is not in use. ● Repair, dismantling, or modification shall be done by experts. ● If the product is modified by customers, it is not our responsibility. Then we cannot assume any responsibility. ● If it is disposed of, treat it as an industrial waste. ● Other than the products listed in the catalog, products for different voltages, etc. are also produced. Please inquire about them with us. <div style="border: 1px solid black; padding: 5px; margin-top: 10px;"> <p>Because a product with motors of Top Runner Efficiency (corresponding to IE3) tends to consume more current than the ones with standard motors (IE1), it requires installation of earth leakage circuit breaker and overload protecting device when the pump is changed from the ones with standard motor.</p> </div>

Notes on ordering

Specification must be discussed thoroughly to produce a reliable product which perfectly satisfies your requirements. Things to confirm when submitting a quote and placing an order are as follows:

- (1) Usage** : If the machine is used for special purposes
- (2) Liquid** : Type, kinematic viscosity, temperature, acidity, inclusion of sediments
- (3) Pump specification** : Total head, amount of discharge, suction head (self-priming height)
- (4) Motor specification** : Power, voltage, frequency, number of phases
- (5) Use circumstances** : Ventilation, circumstance temperature, humidity
- (6) Terminal** : Terminal marking, number of terminals, structure of the terminal box, etc.
- (7) Piping** : Piping diagram
- (8) Installation method** : Self-priming / Immersion type
- (9) Type** : LBK4-60/1-e, etc.
- (10) Standards for compliance**
- (11) Others** : Specification on noise, vibration, or letters on the plate, etc.

Features

- ① Non-seal (mechanical seal-less) structure is adopted.
- ② Three immersion depth options are available.
- ③ The lineup including the models complying with global standards by supporting efficiency and other regulations.
 - Japan : Top Runner efficiency
 - Europe : IE3 efficiency, CE marking (EU Directive) RoHS Directive (2011/65/EU) , 10 substances restricted
 - USA : NEMA Premium efficiency (IE3 efficiency), UL standards (safety)
 - Canada : CSA standards (IE3 efficiency, safety)
 - China : GB3 (GB18613-2020)
- ④ The expanded lineup of VKP-A (flow type) and VKP-H (pressure type) allows for a wider range of head and flow rate selection.
 - The VKP-H achieves approximately 30% higher pressure compared to the VKP-A.



Please note that the paint color, etc. of the actual unit may partially differ from the photo.

Description of types

VKP 08 1 A F T

- ①
- ②
- ③
- ④
- ⑤
- ⑥
- ⑦

- ① Model
- ② Output 03:20W, 04:40W, 05:60W, 06:100W, 07:180W, 08:250W, 09:400W, 11:750W
- ③ Series No.
- ④ Phase, Features (A, J^{NOTE}: 3-phase, flow type, H: 3-phase, pressure type)
 - Note) VKP□□□JT and VKP111AT-e are bottom suction type.
- ⑤ Immersion depth
 - F: 180mm, H: 250mm, K: 350mm
- ⑥ Internal code
- ⑦ None : Standard efficiency / Standard voltage
 - e : Top Runner efficiency (equivalent to IE3) / Standard voltage
 - 4Z : Standard efficiency / Different voltage
 - 4Z-e : Top Runner efficiency (equivalent to IE3) / Different voltage
 - 7W : NEMA premium efficiency motor with UL/CSA certification (For outputs below 750W, efficiency certification is not required; compliance with safety standards only.)

Global standards

Type	Standards/Regulations	Output			
		20W	40W-250W	400W	750W
VKP	IE1 equivalent	●	●	●	X
	CE Marking	●	●	●	
	EU energy efficiency	-	-	-	
	GB3	-	-	-	
VKP-e	Top Runner efficiency (IE3 equivalent)	X	X	X	●
	CE Marking				●
	EU energy efficiency				●
	GB3				●*1
VKP-7W	NEMA Premium efficiency	X	-	-	●
	UL Standards (safety)		●	●	●
	CSA Standards (efficiency)		-	-	●
	CSA Standards (safety)		●	●	●

*1 Dedicated product for attaching GB certification label. ● : Compliant - : Not applicable

Standard Specification

Liquid used	Property of liquid	Grinding liquid, cutting liquid, etc*1.
	Liquid temperature	-20 to 60°C (No frozen liquid)
	Allowable kinematic viscosity	VKP-A 50Hz: 150mm ² /s 60Hz: 75mm ² /s VKP-H 50/60Hz: 32mm ² /s
Installation location		Indoor Ambient temperature: -15 to 40°C, 90%RH or less (No condensation) Height above sea level: 1000m or less Place not exposed to direct sunlight Place in an area free of corrosive or explosive gas or vapor
Material	Casing	FC150
	Impeller	SUS304
	Main shaft	S35C
Shaft seal structure		Non-seal (mechanical seal-less)
Motor	Power source	3-phase 50/60/60Hz 200/200/220V
	Type	Output 250W or less: Totally enclosed self-cooled type Output 400W or more: Totally enclosed fan-cooled indoor type
	Protection method	Output 250W or less: IP54 Output 400W or less: IP44
	Thermal class	B class*2
	Rating	Continuous
	Number of poles	2P
	Standard	IEC60034-1 CE Marking*3
	Bearing	Deep groove ball bearing / Urea grease
Painting	Paint color	Munsell N1 equivalent
	Painting specifications	Epoxy resin paintin

*1 Take note that special liquid such as water, printing liquid or acid liquid cannot be used. Contact us for other special liquid (ceramic, etc.).
*2 -7W type is A class. -7W type is A class.
*3 Excluding -7W type.

Table of Consumable Parts

Type	Bearing	
	Load side	Unload side
VKP031AT	6200ZZ	6200CXZZ
VKP041AT(-4Z/7W)	6200ZZ	6200CXZZ
VKP051AT(-4Z/7W)	6203ZZ	6201CXZZ
VKP061AT(-4Z/7W)	6203ZZ	6201CXZZ
VKP071AT(-4Z/7W)	6203ZZ	6201CXZZ
VKP071AHT(-4Z/7W)	6203ZZ	6201CXZZ
VKP071AKT(-4Z/7W)	6206ZZ	6201CXZZ
VKP071JT(-4Z/7W)	6004ZZ	6201CXZZ
VKP081AT(-4Z/7W)	6203ZZ	6201CXZZ
VKP081AFT(-4Z/7W)	6203ZZ	6201CXZZ
VKP081AKT(-7W)	6203ZZ	6201CXZZ
VKP081JT(-4Z/7W)	6004ZZ	6201CXZZ
VKP091AT(-4Z/7W)	6203ZZ	6201CXZZ
VKP091AFT(-4Z/7W)	6203ZZ	6201CXZZ
VKP091AKT(-4Z/7W)	6206ZZ	6201CXZZ
VKP091JT(-4Z/7W)	6004ZZ	6201CXZZ
VKP111AT-e(-4Z/7W)	6004ZZ	6203CXZZ
VKP051HT(-4Z/7W)	6203ZZ	6201CXZZ
VKP061HT(-4Z/7W)	6203ZZ	6201CXZZ
VKP071HT(-4Z/7W)	6203ZZ	6201CXZZ
VKP081HT(-4Z/7W)	6203ZZ	6201CXZZ
VKP091HT(-4Z/7W)	6203ZZ	6201CXZZ

Selection chart

VKP-A type

(Values at kinematic viscosity 1mm²/s, specific gravity 1)

Synchronous rotating speed 50Hz : 3000min⁻¹
60Hz : 3600min⁻¹

●VKP031AT

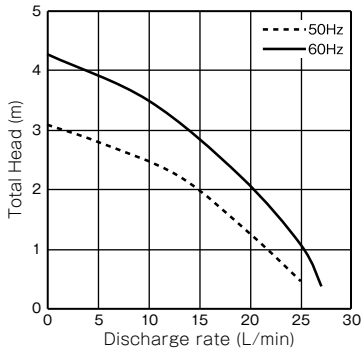

●VKP041AT

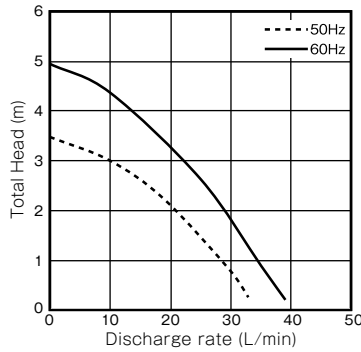

●VKP051AT

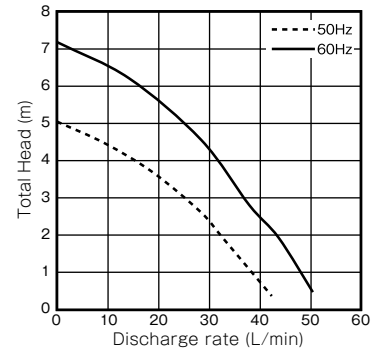

●VKP061AT

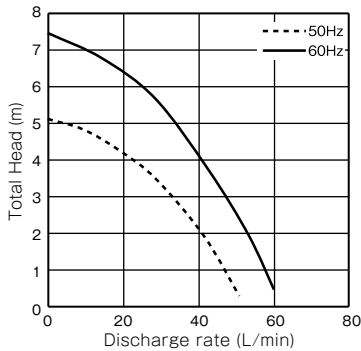

●VKP071AT

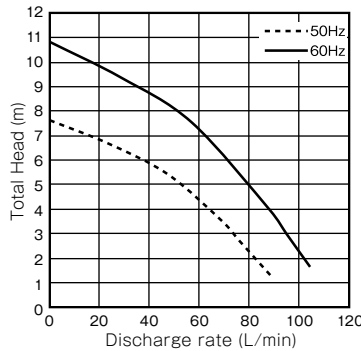

●VKP071AHT (AKT)

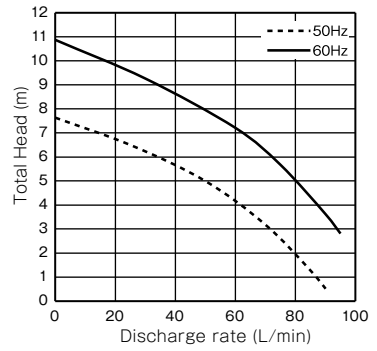

●VKP071JT

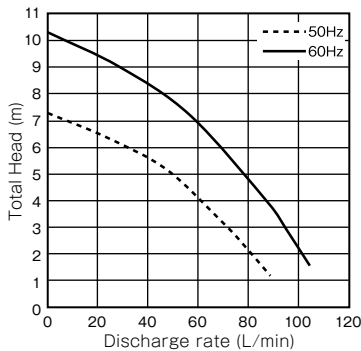

●VKP081AT (AFT)

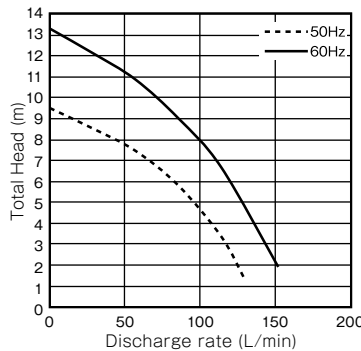

●VKP081AKT

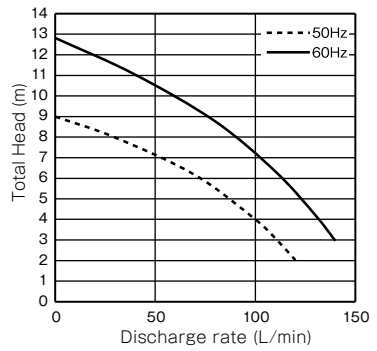

●VKP081JT

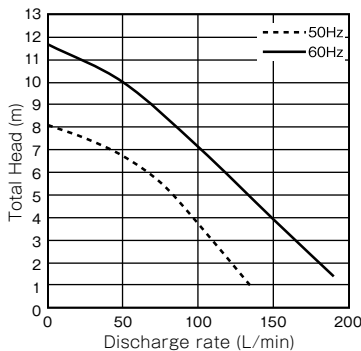

●VKP091AT (AFT)

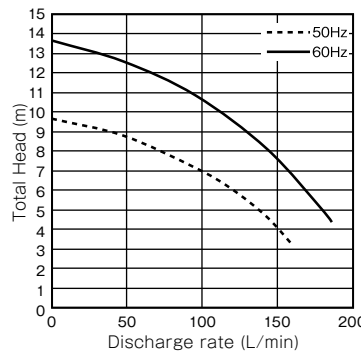

●VKP091AKT

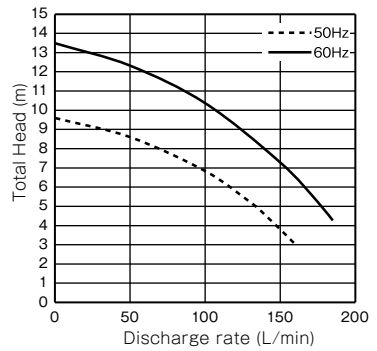

●VKP091JT

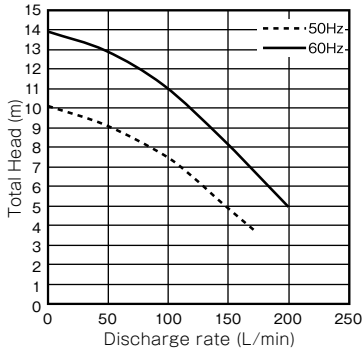

●VKP111AT-e

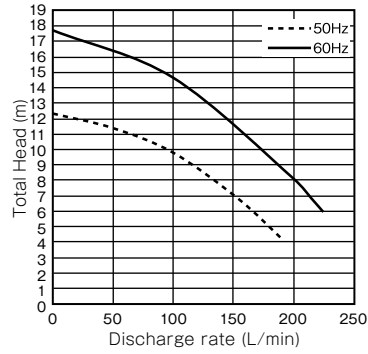

※ Above selection chart is also available for -4Z/-7W.

Note 1) Take note that discharge rate varies considerably depending on the type and kinematic viscosity of liquid used.

VKP-H type

(Values at kinematic viscosity 1mm²/s, specific gravity 1)

Synchronous rotating speed 50Hz : 3000min⁻¹
60Hz : 3600min⁻¹

●VKP051HT

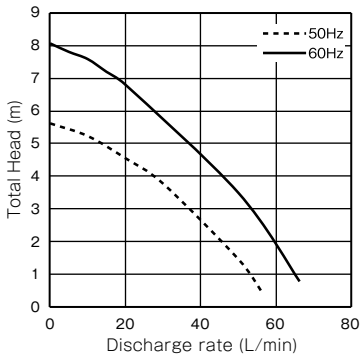

●VKP061HT

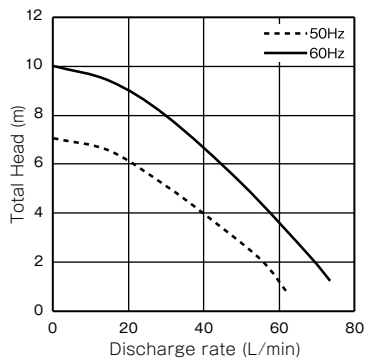

●VKP071HT

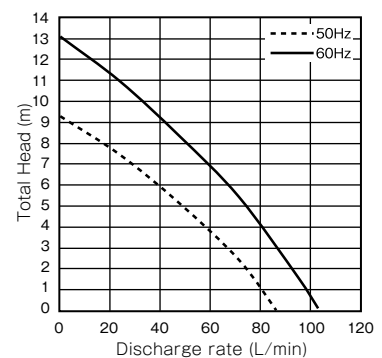

●VKP081HT

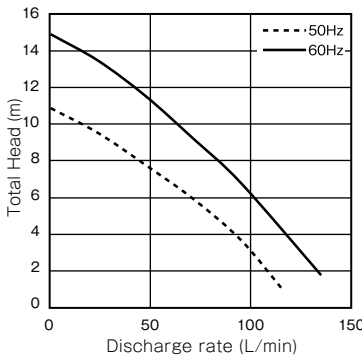

●VKP091HT

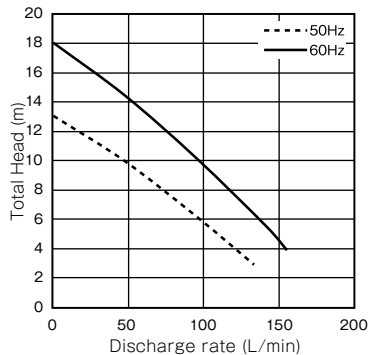

※ Above selection chart is also available for -4Z/-7W.

Note 1) Please note that discharge rate varies considerably depending on the type and kinematic viscosity of liquid used.

Specification table

VKP type

Bore diameter (Rp)	Type	Output (W)	50Hz					60Hz					Protection method
			Rated voltage V	Rated current A	Starting current A	Discharge rate L/min	Total head m	Rated voltage V	Rated current A	Starting current A	Discharge rate L/min	Total head m	
1/4	VKP031AT	20	200	0.18	0.43	13	2	200/220	0.19/0.18	0.42/0.46	18	2	IP54
	VKP041AT	40	200	0.32	1.1	22	1.5	200/220	0.32/0.31	1.03/1.14	28	1.5	
	VKP041AT-4Z		380/400/415	0.16/0.16/0.17	0.6/0.7/0.7			400/440/460	0.16/0.16/0.16	0.5/0.6/0.6			
	VKP041AT-7W							208/230/460	0.3/0.2	1.1/1.3			
3/8	VKP051AT	60	200	0.50	2.5	32	2	200/220	0.55/0.55	2.4/2.7	43	2	
	VKP051AT-4Z		380/400/415	0.25/0.25/0.25	1.3/1.4/1.4			400/440/460	0.27/0.27/0.27	1.3/1.4/1.5			
	VKP051AT-7W							208/230/460	0.4/0.4/0.2	2.7/2.9/1.7			
	VKP061AT	100	200	0.70	2.9	41	2	200/220	0.75/0.75	2.8/3.1	53	2	
	VKP061AT-4Z		380/400/415	0.35/0.35/0.35	1.65/1.7/1.8			400/440/460	0.38/0.38/0.38	1.6/1.7/1.8			
	VKP061AT-7W							208/230/460	0.5/0.5/0.3	3.1/3.4/1.9			
1/2	VKP071AT	180	200	1.1	6	73	3	200/220	1.2/1.2	5.6/6.1	95	3	
	VKP071AT-4Z		380/400/415	0.55/0.55/0.55	2.8/3.0/3.0			400/440/460	0.6/0.6/0.6	2.8/3.1/3.2			
	VKP071AT-7W							208/230/460	0.8/0.8/0.4	6.1/6.8/3.6			
	VKP071JT	180	200	1.1	6	73	3	200/220	1.2/1.2	5.6/6.1	95	3	
	VKP071JT-4Z		380/400/415	0.55/0.55/0.55	2.8/3.0/3.0			400/440/460	0.6/0.6/0.6	2.8/3.1/3.2			
	VKP071JT-7W							208/230/460	0.8/0.8/0.4	6.1/6.8/3.6			
	VKP071AHT	180	200	1.1	6	70	3	200/220	1.2/1.2	5.6/6.1	90	3	
	VKP071AHT-4Z		380/400/415	0.55/0.55/0.55	2.8/3.0/3.0			400/440/460	0.6/0.6/0.6	2.8/3.1/3.2			
	VKP071AHT-7W							208/230/460	0.8/0.8/0.4	6.1/6.8/3.6			
	VKP071AKT	180	200	1.1	6	70	3	200/220	1.2/1.2	5.6/6.1	90	3	
	VKP071AKT-4Z		380/400/415	0.55/0.55/0.55	2.8/3.0/3.0			400/440/460	0.6/0.6/0.6	2.8/3.1/3.2			
	VKP071AKT-7W							208/230/460	0.8/0.8/0.4	6.1/6.8/3.6			
3/4	VKP081AT	250	200	1.3	7.5	105	4	200/220	1.5/1.5	6.9/7.6	135	4	
	VKP081AT-4Z		380/400/415	0.65/0.65/0.65	3.5/3.7/3.8			400/440/460	0.75/0.75/0.75	3.3/3.7/3.8			
	VKP081AT-7W							208/230/460	1.1/1.0/0.5	7.5/8.3/4.1			
	VKP081JT	250	200	1.3	7.5	93	4	200/220	1.5/1.5	6.9/7.6	135	4	
	VKP081JT-4Z		380/400/415	0.65/0.65/0.65	3.5/3.7/3.8			400/440/460	0.75/0.75/0.75	3.3/3.7/3.8			
	VKP081JT-7W							208/230/460	1.1/1.0/0.5	7.5/8.3/4.1			
	VKP081AFT	250	200	1.3	7.5	105	4	200/220	1.5/1.5	6.9/7.6	135	4	
	VKP081AFT-4Z		380/400/415	0.65/0.65/0.65	3.5/3.7/3.8			400/440/460	0.75/0.75/0.75	3.3/3.7/3.8			
	VKP081AFT-7W							208/230/460	1.1/1.0/0.5	7.5/8.3/4.1			
	VKP081AKT	250	200	1.3	7.5	100	4	200/220	1.5/1.5	6.9/7.6	130	4	
	VKP081AKT-4Z		380/400/415	0.65/0.65/0.65	3.5/3.7/3.8			400/440/460	0.75/0.75/0.75	3.3/3.7/3.8			
	VKP081AKT-7W							208/230/460	1.1/1.0/0.5	7.5/8.3/4.1			
1	VKP091AT	400	200	2.1	9.6	137	5	200/220	2.4/2.4	9.1/10.0	180	5	
	VKP091AT-4Z		380/400/415	1.05/1.05/1.05	4.6/4.8/5.0			400/440/460	1.2/1.2/1.2	4.6/5.0/5.2			
	VKP091AT-7W							208/230/460	1.6/1.5/0.8	9.9/11/5.5			
	VKP091JT	400	200	2.1	9.6	142	5	200/220	2.4/2.4	9.1/10.0	185	5	
	VKP091JT-4Z		380/400/415	1.05/1.05/1.05	4.6/4.8/5.0			400/440/460	1.2/1.2/1.2	4.6/5.0/5.2			
	VKP091JT-7W							208/230/460	1.6/1.5/0.8	9.9/11/5.5			
	VKP091AFT	400	200	2.1	9.6	137	5	200/220	2.4/2.4	9.1/10.0	180	5	
	VKP091AFT-4Z		380/400/415	1.05/1.05/1.05	4.6/4.8/5.0			400/440/460	1.2/1.2/1.2	4.6/5.0/5.2			
	VKP091AFT-7W							208/230/460	1.6/1.5/0.8	9.9/11/5.5			
	VKP091AKT	400	200	2.1	9.6	130	5	200/220	2.4/2.4	9.1/10.0	175	5	
	VKP091AKT-4Z		380/400/415	1.05/1.05/1.05	4.6/4.8/5.0			400/440/460	1.2/1.2/1.2	4.6/5.0/5.2			
	VKP091AKT-7W							208/230/460	1.6/1.5/0.8	9.9/11/5.5			
	VKP111AT-e	750	200	3.3	27.2	128	7	200/220	4.5/4.2	26.9/28.9	182	7	
	VKP111AT-4Z-e		380/400/415	1.7/1.7/1.7	12.9/14.4/15.1			400/440/460	2.3/2.3/2.3	13.5/13.8/16.0			
VKP111AT-7W					208/230/460			3.1/2.9/1.5	29/31/17				

Note 1) The discharge rate and total head are values obtained from tests conducted at a kinematic viscosity of 1mm²/s (same as normal temperature fresh water).

Take note that the pumps cannot be used with water.

Note 2) The rated current in the table above (rated current shown on the pump nameplate) is the recommended set current of the protective device.

Note 3) VKP □□□ JT(-□) and VKP111A(-□) are bottom suction type.

VKP-H type

Bore diameter (Rp)	Type	Output (W)	50Hz					60Hz					Protection method
			Rated voltage V	Rated current A	Starting current A	Discharge rate L/min	Total head m	Rated voltage V	Rated current A	Starting current A	Discharge rate L/min	Total head m	
3/8	VKP051HT	60	200	0.7	2.9	10	5	200/220	0.75/0.75	2.8/3.1	10	7.5	
	VKP051HT-4Z		380/400/415	0.35/0.35/0.35	1.7/1.7/1.8			400/440/460	0.38/0.38/0.38	1.6/1.7/1.8			
	VKP051HT-7W							208/230/460	0.4/0.4/0.2	2.7/2.9/1.7			
	VKP061HT	100	200	0.7	2.9	10	6.5	200/220	0.75/0.75	2.8/3.1	10	9	
VKP061HT-4Z	380/400/415		0.35/0.35/0.35	1.7/1.7/1.8	400/440/460			0.38/0.38/0.38	1.6/1.7/1.8				
VKP061HT-7W					208/230/460			0.5/0.5/0.3	3.1/3.4/1.9				
1/2	VKP071HT	180	200	1.2	7.3	20	7.5	200/220	1.3/1.3	6.8/7.5	20	11	
	VKP071HT-4Z		380/400/415	0.6/0.6/0.6	3.5/3.7/3.8			400/440/460	0.65/0.65/0.65	3.3/3.7/3.8			
	VKP071HT-7W							208/230/460	0.8/0.8/0.4	6.1/6.8/3.6			
3/4	VKP081HT	250	200	1.4	7.3	20	9.5	200/220	1.6/1.6	6.8/7.5	20	13.5	
	VKP081HT-4Z		380/400/415	0.7/0.7/0.7	3.5/3.7/3.8			400/440/460	0.8/0.8/0.8	3.3/3.7/3.8			
	VKP081HT-7W							208/230/460	1.1/1.0/0.5	7.5/8.3/4.1			
1	VKP091HT	400	200	2.1	9.6	20	11.5	200/220	2.4/2.4	9.1/10.0	20	16.5	
	VKP091HT-4Z		380/400/415	1.05/1.05/1.05	4.6/4.8/5.0			400/440/460	1.2/1.2/1.2	4.6/5.0/5.2			
	VKP091HT-7W							208/230/460	1.6/1.5/0.8	9.9/11/5.5			

Note 1) The discharge rate and total head are values obtained from tests conducted at a kinematic viscosity of 1mm²/s (same as normal temperature fresh water).

Take note that the pumps cannot be used with water.

Note 2) The rated current in the table above (rated current shown on the pump nameplate) is the recommended set current of the protective device.

Note 3) In case of output 100W, please select VKP061AT(-□).

Assembly drawing

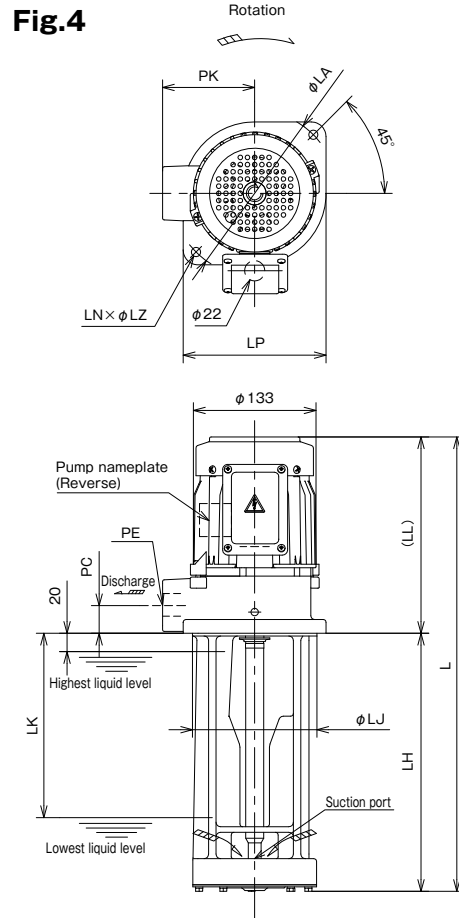
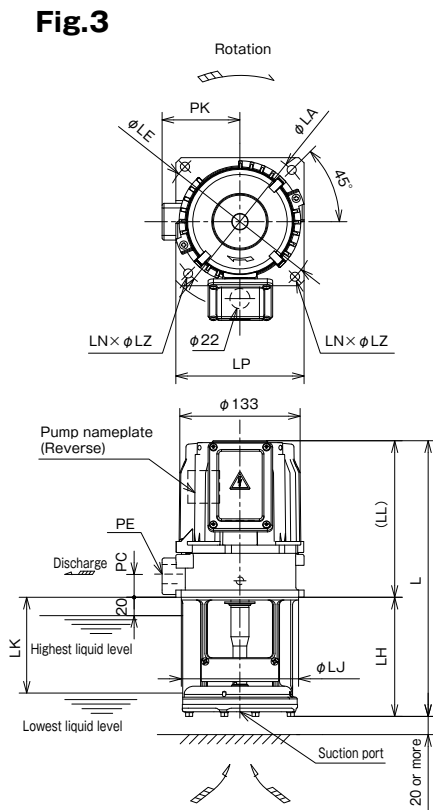
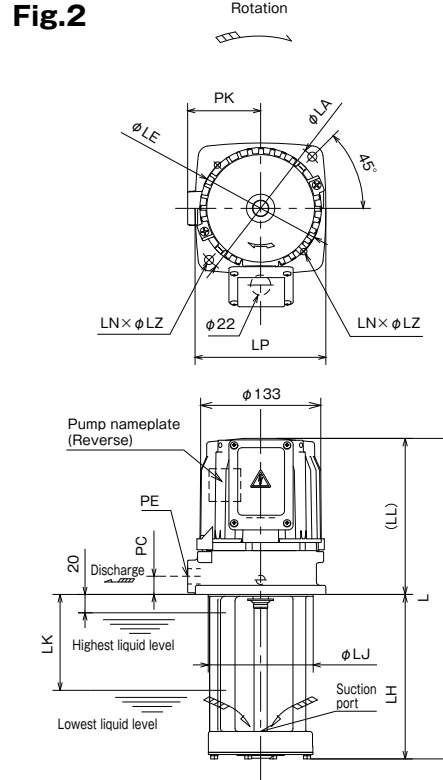
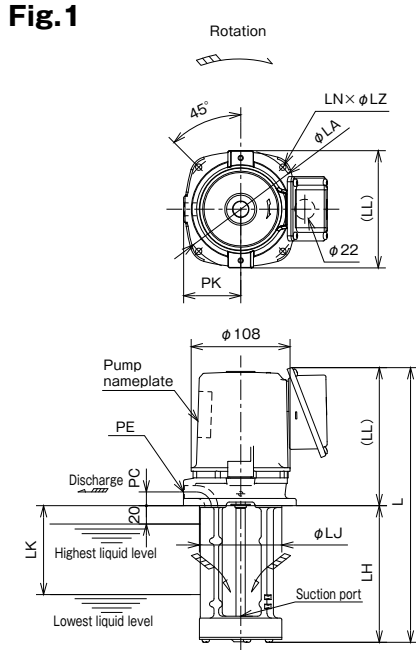
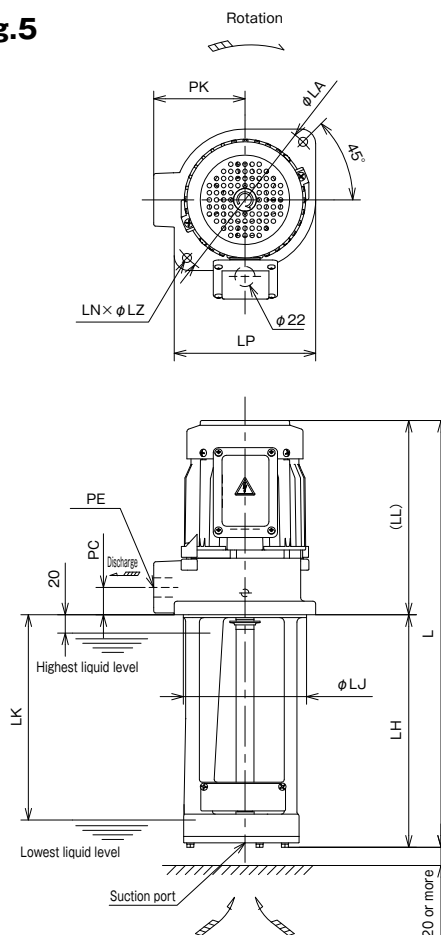

Fig.5



Dimensions

VKP type

(Unit : mm)

Type	Output (kW)	Fig.	LA	LE	LP	LN	LZ	LJ	PE	PC	PK	L	LH	LL	LK	Power supply terminal screw size	Ground terminal screw size	Approx. mass (kg)
VKP031AT	0.02	1	130	—	128	4	7	90	Rp 1/4	15	62.5	297	146	151	103	M4	M4	5.8
VKP041AT(-4Z/7W)	0.04	1	130	—	128	4	7	90	Rp 1/4	15	62.5	300	149	151	97	M4	M4	6.2
VKP051AT(-4Z/7W)	0.06	2	132	130	125	2/2	7/7	90	Rp 3/8	15	71	281	150	131	100	M4	M4	7.6
VKP061AT(-4Z/7W)	0.10	2	132	134	125	2/2	7/7	90	Rp 3/8	15	71	281	150	131	90	M4	M4	7.6
VKP071AT(-4Z/7W)	0.18	2	160	134	143	2/2	10/7	115	Rp 1/2	20	80	351	180	171	105	M4	M4	10.4
VKP071JT(-4Z/7W)	0.18	3	160	134	140	2/2	10/7	115	Rp 1/2	20	80	301	130	171	110	M4	M4	11.0
VKP071AHT(-4Z/7W)	0.18	2	160	134	143	2/2	10/7	115	Rp 1/2	20	80	421	250	171	175	M4	M4	10.0
VKP071AKT(-4Z/7W)	0.18	2	160	134	143	2/2	10/7	115	Rp 1/2	20	80	521	350	171	275	M4	M4	11.0
VKP081AT(-4Z/7W)	0.25	2	160	170	140	2/2	10/10	128	Rp 3/4	25	85	421	250	171	190	M4	M4	13.0
VKP081JT(-4Z/7W)	0.25	3	160	170	140	2/2	10/10	128	Rp 3/4	25	85	301	130	171	105	M4	M4	11.8
VKP081AFT(-4Z/7W)	0.25	2	160	170	140	2/2	10/10	128	Rp 3/4	25	85	351	180	171	120	M4	M4	12.5
VKP081AKT(-4Z/7W)	0.25	2	160	170	140	2/2	10/10	128	Rp 3/4	25	85	527	350	177	265	M4	M4	16.0
VKP091AT(-4Z/7W)	0.40	4	180	—	155	2	10	135	Rp 1	30	100	493	280	213	200	M4	M4	16.4
VKP091JT(-4Z/7W)	0.40	5	180	—	155	2	10	135	Rp 1	30	100	463	250	213	225	M4	M4	16.0
VKP091AFT(-4Z/7W)	0.40	4	180	—	155	2	10	135	Rp 1	30	100	393	180	213	60	M4	M4	17.0
VKP091AKT(-4Z/7W)	0.40	4	180	—	155	2	10	135	Rp 1	30	100	563	350	213	230	M4	M4	18.0
VKP111AT-e(-4Z/7W)	0.75	5	180	—	165	2	10	152	Rp 1	30	100	558	285	273	240	M4	M4	21.0

VKP-H type

(Unit : mm)

Type	Output (kW)	Fig.	LA	LE	LP	LN	LZ	LJ	PE	PC	PK	L	LH	LL	LK	Power supply terminal screw size	Ground terminal screw size	Approx. mass (kg)
VKP051HT(-4Z/7W)	0.06	2	132	134	125	2/2	7/7	107	Rp 3/8	15	71	281	150	131	100	M4	M4	8.4
VKP061HT(-4Z/7W)	0.10	2	132	134	125	2/2	7/7	107	Rp 3/8	15	71	281	150	131	100	M4	M4	8.4
VKP071HT(-4Z/7W)	0.18	2	160	—	140	2	10	128	Rp 1/2	20	80	351	180	171	130	M4	M4	9.6
VKP081HT(-4Z/7W)	0.25	2	160	—	150	2	10	135	Rp 3/4	25	85	421	250	171	190	M4	M4	11.9
VKP091HT(-4Z/7W)	0.40	4	180	—	165	2	10	152	Rp 1	30	100	491	280	211	210	M4	M4	14.5

■ Detailed drawing of the terminal box

●VKP031AT~111AT-e (-4Z)
VKP051HT~091HT (-4Z)

■ Assembly drawing

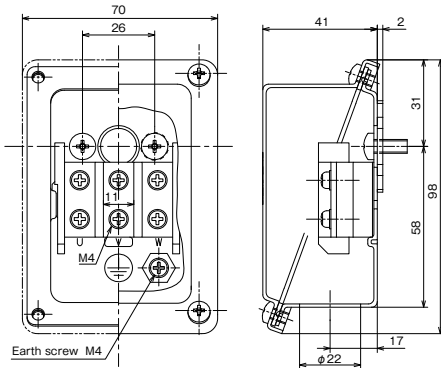

■ Connection diagram

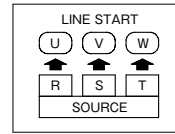

※ CE marked product

※ IP54-equivalent protective structure (However, for wiring ports, please use wiring pipes (conduits) with IP54 or higher.)

●VKP041AT-7W

■ Assembly drawing

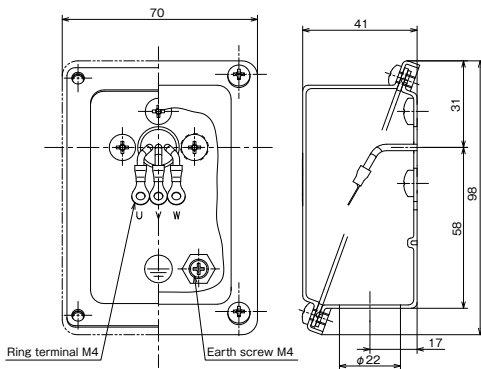

■ Connection diagram

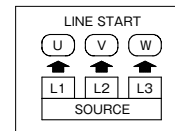

●VKP051AT-7W~111AT-7W
VKP051HT-7W~091HT-7W

■ Assembly drawing

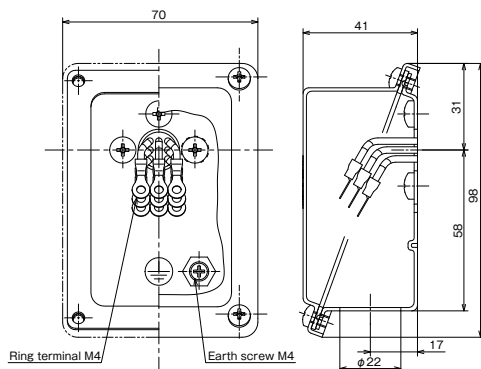

■ Connection diagram

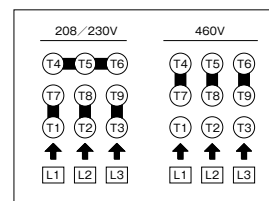

■ Sectional drawing

● VKP031AT ~ VKP091A □ T(-4Z/-7W)
VKP051HT ~ VKP091HT

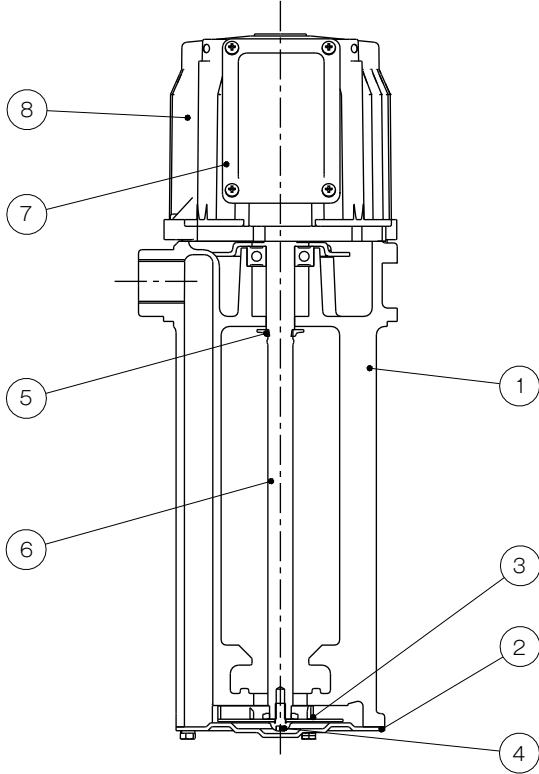

No.	Part name	Material	No.	Part name	Material
1	Casing	FC150	5	flange	NBR
2	Bottom plate	SEHC	6	Main shaft	S35C
3	Impeller	SUS304	7	Terminal box	SPCE
4	SEMS screw	SWCH	8	Motor	—

Note 1) Structure and other details are subject to change without notice.

● VKP111AT-e(-4Z/-7W)

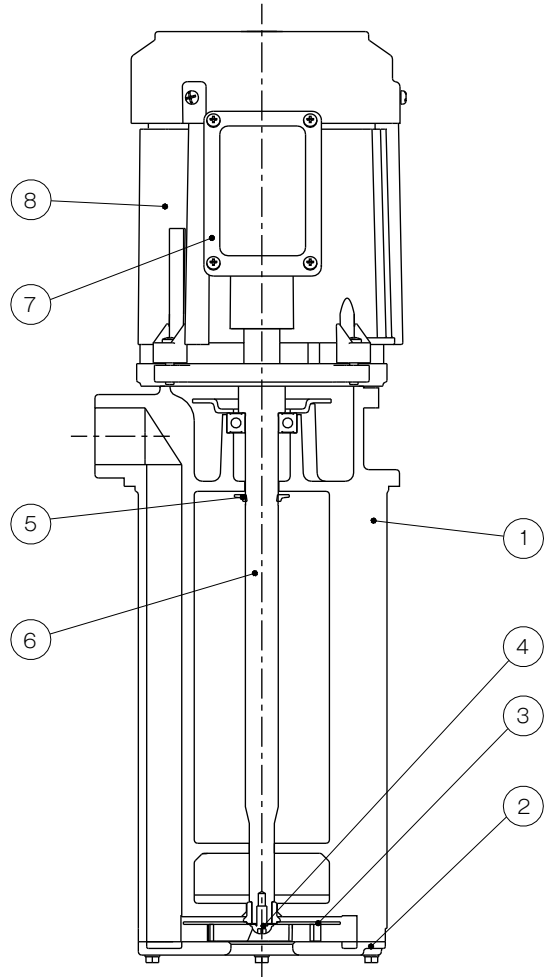

No.	Part name	Material	No.	Part name	Material
1	Casing	FC150	5	flange	NBR
2	Bottom plate	FC150	6	Main shaft	S35C
3	Impeller	SUS304	7	Terminal box	SPCE
4	SEMS screw	SWCH	8	Motor	—

Note 1) Structure and other details are subject to change without notice.

Features

- ① The LFE-e model is an energy-saving pump with a Top Runner (equivalent to IE3) motor.
(The mounting dimension is compatible with conventional models.)
- ② High-efficiency pumps designed for energy-saving coolant piping
- ③ Non-seal (mechanical seal-less) structure is adopted for excellent durability.

Description of types

LFE 32 A - 0.25 - 300 -e

① ② ③ ④ ⑤ ⑥

- ① Model
- ② Bore diameter
- ③ Liquid viscosity
A: for low viscosity liquid
- ④ Output
- ⑤ Immersion depth
- ⑥ Motor efficiency
None: Standard efficiency (equivalent to IE1)
-e : Top Runner efficiency (equivalent to IE3)



Please note that the paint color, etc. of the actual unit may partially differ from the photo.

Standard Specification

Model		LFE	LFE-e
Used liquid	Property of liquid	Water-soluble coolant	
	Temperature	0-60 °C (No frozen liquid)	
	Allowable kinematic viscosity	1mm ² /s	
Installation location		Indoor Ambient temperature: 0 to 40 °C, RH 85% or below (no condensation), Height above sea level : 1000m or less. Place not exposed to direct sunlight, Place in an area free of corrosive or explosive gas or vapor.	
Material	Section/Discharge casing	FC200	
	Impeller	FCD450	
	Main shaft	S35C	
Shaft seal structure		Non-seal (mechanical seal-less)	
Motor	Power source	3-phase 60Hz 200/220V	
	Output	0.25~0.4kW	0.6~0.75kW
	Type	Totally enclosed self-cooling motor	Totally enclosed fan-cooled indoor type
	Protection method	IP43	IP44
	Thermal class	F	
	Rating	Continuous	
Number of poles		2P	
Paint color		Munsell N1.5	

Table of Consumable Parts

Type	O-ring			Bearing		Oil seal
	For discharge bushing	Wearing ring	For companion flange	Load side	Unload side	
LFE32A-0.25-300	G35	G65	G50	6205ZZC3	6203ZZC3	G25355
LFE50A-0.35-300						
LFE50A-0.4-300		G75	G75			
LFE50A-0.6-300-e						
LFE65A-0.75-300-e		G80	G90			

Selection chart

(Values at kinematic viscosity 1mm²/s, specific gravity 1)

60Hz only

Synchronous rotating speed 3600min⁻¹

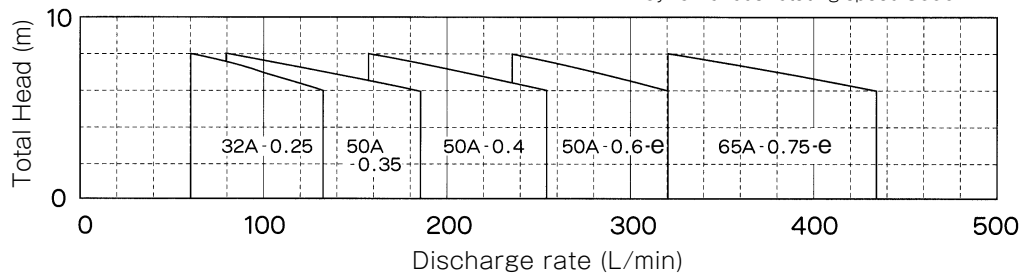

Specification table

Bore diameter (mm)	Frequency (Hz)	Type	Rated voltage (V)	Output (kW)	Rated current (A)	Starting current (A)	Discharge rate (L/min)	Total head (m)
32	60	LFE32A-0.25-300	200/220	0.25	1.16/1.10	7.2/7.9	60-130	8-6
		LFE50A-0.35-300		0.35	1.90/1.82	13.0/14.0	80-185	
LFE50A-0.4-300		0.4		1.90/1.82	13.0/14.0	160-255		
LFE50A-0.6-300-e		0.6		3.5/3.5	29.0/32.0	235-320		
65		LFE65A-0.75-300-e		0.75	3.5/3.5	29.0/32.0	320-430	

※ The pump's rated current (current value listed on the pump nameplate) is the recommended current setting for protection device.

Assembly drawing

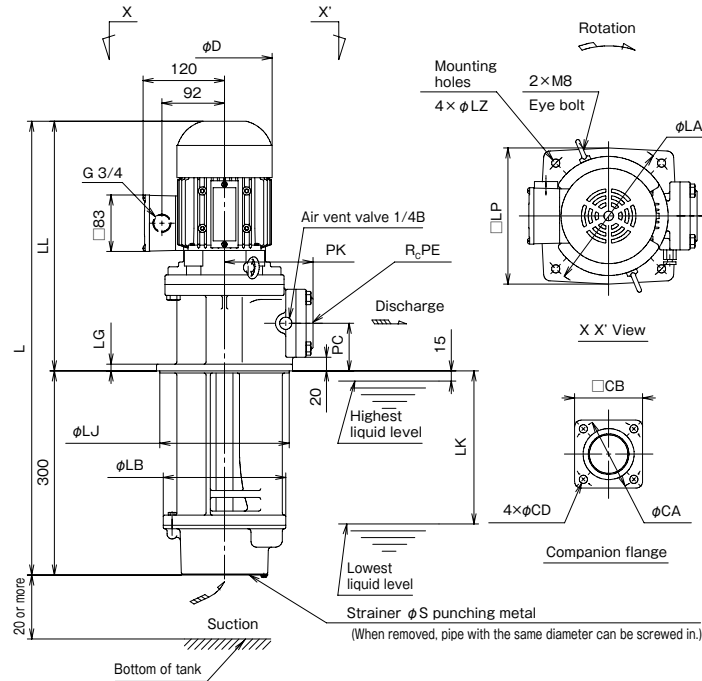

Dimensions

(Unit : mm)

Bore diameter	Type	PE	D	L	LL	LK	LJ	LB	LG	PK	PC	LP	LZ	LA	S	CA	CB	CD	Approx. mass(kg)
32	LFE32A-0.25-300	1 1/4	157	625.5	325.5	240	160	150	10	120	55	180	10	200	7	70	70	10	29
50	LFE50A-0.35-300	2	157	659.5	359.5	225	190	180	10	130	70	200	12	220	7	105	100	12	34
	LFE50A-0.4-300	2	157	659.5	359.5	225	190	180	10	130	70	200	12	220	7	105	100	12	34
	LFE50A-0.6-300-e	2	140	667	367	225	190	180	10	130	70	200	12	220	7	105	100	12	35
65	LFE65A-0.75-300-e	2 1/2	140	692	392	200	220	210	12	150	80	230	15	250	8	125	120	15	42

Detailed drawing of terminal box

Sectional drawing

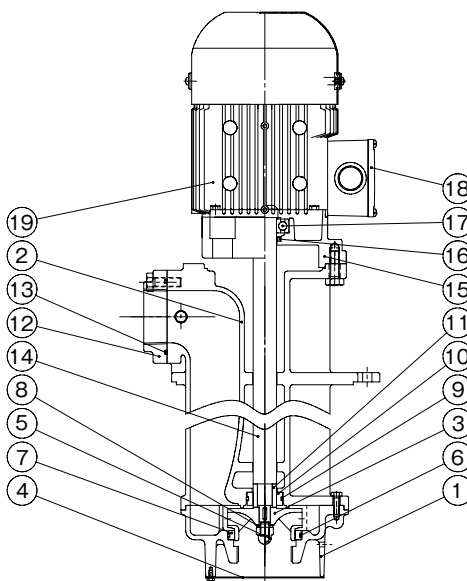
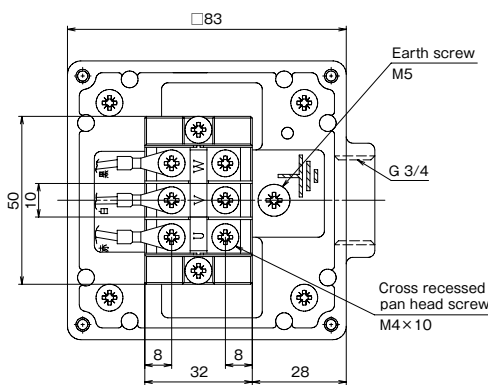

No.	Part name	Qty	Material
1	Suction casing	1	FC200
2	Discharge casing	1	FC200
3	Impeller	1	FCD450
4	Strainer	1	SUS304*
5	Impeller nut	1	SUS304
6	O-ring	1	NBR
7	Wearing ring	1	PTFE
8	Washer	1	SUS304
9	O-ring	1	NBR
10	Discharge bushing	1	PTFE
11	Shaft sleeve	1	SUS304
12	Companion flange	1	FC200
13	O-ring	1	NBR
14	Main shaft	1	S35C
15	Motor bracket	1	FC200
16	Oil seal	1	NBR
17	Load-side bearing	1	SUJ2
18	Terminal box	1	ADC
19	Motor	1	

* SS400 for LFE65-e.

Note 1) The materials in the table above are equivalents.

Note 2) Structure and other details are subject to change without notice.

Features

- ① Energy-saving pump with a Top Runner (equivalent to IE3) motor.
- ② Though it is small, it is specified for high-pressure.
- ③ Non-seal structure (mechanical seal-less) is adopted for excellent durability.
- ④ Special reliable resin is used in the main part of the pump.
- ⑤ The mounting dimension is compatible with conventional models.

Description of types

LHW 20 3 A 0.75 T -e

- ① ② ③ ④ ⑤ ⑥ ⑦

- ① Model
- ② Bore diameter
- ③ Number of impellers
- ④ Liquid viscosity
A : for low viscosity liquid
- ⑤ Output
- ⑥ ID code
- ⑦ Top Runner efficiency (equivalent to IE3)



Please note that the paint color, etc. of the actual unit may partially differ from the photo.

Standard Specification

Used liquid	Property of liquid	Water-soluble coolant, cleaning liquid (weak alkaline)
	Temperature	0-60 °C (No frozen liquid)
	Allowable kinematic viscosity	1mm ² /s
Installation location		Indoor Ambient temperature: 0 to 40 °C, RH 85% or below (no condensation). Height above sea level : 1000m or less. Place not exposed to direct sunlight. Place in an area free of corrosive or explosive gas or vapor.
Material	Suction cover/ Discharge casing	FC200
	Intermediate casing	ARLS
	Impeller	(Special polyamide resin reinforced with glass fiber, etc.)
Main shaft		equivalent to SUS420J2
Shaft seal structure		Non-seal (mechanical seal-less)
Motor	Power source	3-phase 50/60/60Hz 200/200/220V
	Type	Totally enclosed fan-cooled indoor type
	Protection method	IP44
	Thermal class	B
	Rating	Continuous
Number of poles		2P
Paint color		Munsell N1 or N1.5

Table of Consumable Parts

Output (kW)	Bearing		Oil seal	V ring	O-ring (for outer cylinder)	O-ring (for discharge casing)
	Load side	Unload side				
0.75	6205ZZC3	6203CXZZC3	D20387	VR20A	G115	G110
1.1						

* A set of replacement parts is available. Please contact the nearest sales office.

Specification table

Frequency (Hz)	Bore diameter (A)	Type	Rated voltage (V)	Output (kW)	Rated current (A)	Starting current (A)	Discharge rate (L/min)	Total head (m)
50	20	LHW202A0.75T-e	200	0.75	3.2	24.6	20-70	20.4-10.8
		LHW203A0.75T-e		0.75	3.2	24.6	20-70	30.2-15.3
		LHW204A1.1T-e		1.1	4.4	38.4	20-80	40.7-14.3
		LHW205A1.1T-e		1.1	4.4	38.4	20-70	50.2-25.6
60	20	LHW202A0.75T-e	200/220	0.75	3.3/3.1	23.4/28.3	20-80	29.1-16.5
		LHW203A0.75T-e		0.75	3.3/3.1	23.4/28.3	20-80	42.6-22.4
		LHW204A1.1T-e		1.1	5.1/4.8	36.8/40.6	20-90	57.6-23.4
		LHW205A1.1T-e		1.1	5.1/4.8	36.8/40.6	20-50	70.8-59.7

* The pump's rated current (current value listed on the pump nameplate) is the recommended current setting for protection device.

Selection chart

(Values at kinematic viscosity 1mm²/s, specific gravity 1)
(Based on JIS B 8301:2018 Grade 3B)

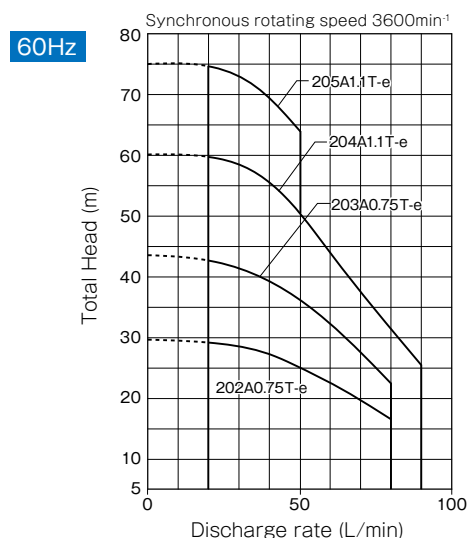
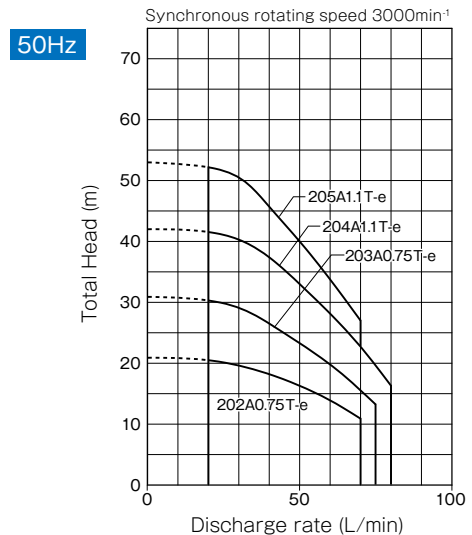

■ Assembly drawing

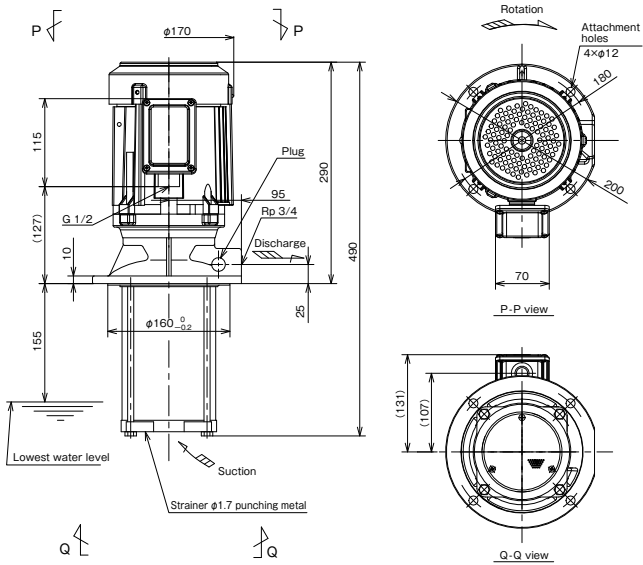

■ Detailed drawing of the Terminal Box

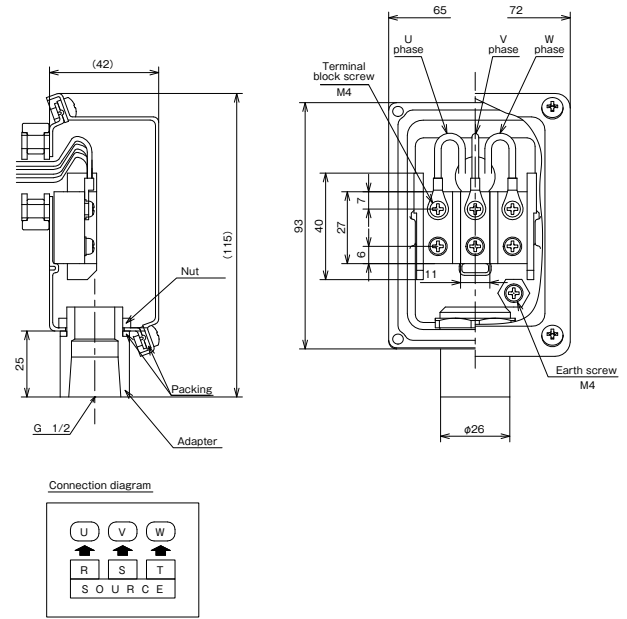

■ Dimensions

Bore diameter	Type	Approx. mass(kg)
20	LHW202A0.75T-e	21
	LHW203A0.75T-e	21
	LHW204A1.1T-e	22
	LHW205A1.1T-e	22

■ Sectional drawing

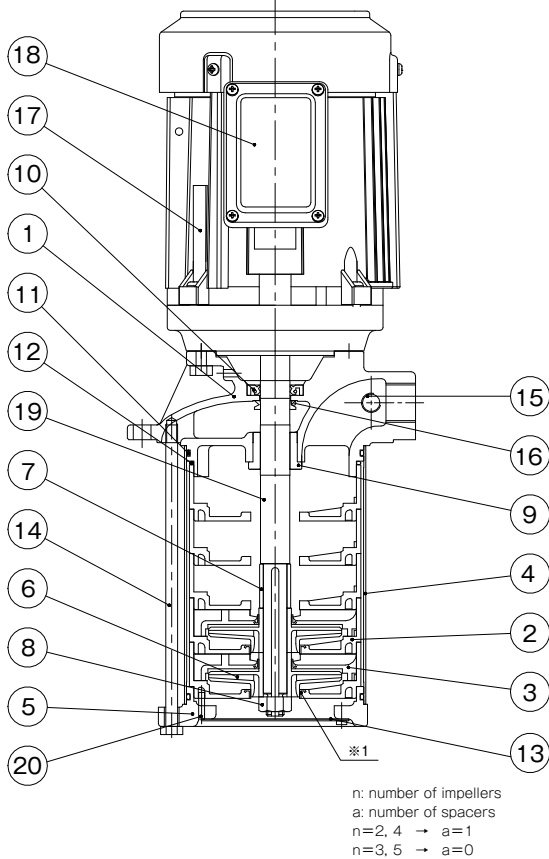

No.	Part name	Qty	Material
1	Discharge casing	1	FC200
2	Intermediate casing	5	ARLS
3	Guide vane	n	ARLS
4	External cylinder	1	SUS304
5	Suction cover	1	FC200
6	Impeller	n	ARLS
7	Spacer	a	SUS304
8	Impeller nut	1	SUS304
9	Discharge bushing	1	FCD450
10	Oil seal	1	NBR
11	O-ring	2	NBR
12	O-ring	1	NBR
13	Strainer	1	SUS304
14	Through bolt	4	SS400
15	Plug	1	SWCH
16	V ring	1	NBR
17	Motor	1	
18	Terminal box	1	
19	Motor shaft	1	S35C + SUS420J2
20	Spring pin	1	

※ 1 The intermediate casing without an impeller does not come with a stainless steel ring.
Note 1) The materials in the table above are equivalents.
Note 2) Structure and other details are subject to change without notice.

n: number of impellers
a: number of spacers
n=2,4 → a=1
n=3,5 → a=0

Features

- ① An energy-saving pump with a Top Runner (equivalent to IE3) motor.
- ② Strong and tough enough to resist dirty coolants.
- ③ The impeller is made of FCD and is highly durable.
- ④ With two immersion depth options (short leg and long leg), the pump can be selected according to the tank depth.
- ⑤ Can be used for high viscosity coolants (LFO□□B-e model).
- ⑥ Non-seal (mechanical seal-less) structure is adopted for excellent durability.
- ⑦ The lineup including the models complying with global standards by supporting efficiency and other regulations.
Japan : Top Runner efficiency
China : GB3 (GB18613-2020)
- ⑧ Mounting dimensions are compatible with conventional pumps.



Please note that the paint color, etc. of the actual unit may partially differ from the photo.

Description of types

LFO 50 A - 0.75 - 35 -e

① ② ③ ④ ⑤ ⑥

- ① Model
- ② Bore diameter
- ③ Liquid viscosity A : for low viscosity liquid B : for high viscosity liquid
- ④ Output
- ⑤ Immersion depth 35:350mm 50:500mm
- ⑥ Motor efficiency Top Runner efficiency (equivalent to IE3)

Standard Specification

Used liquid	Property of liquid	Liquids containing additives (anticorrosive, etc.), for water-soluble and water-insoluble coolants*
	Temperature	0 to 60° C (No frozen liquid)
	Allowable kinematic viscosity	LFO-A : 32mm ² /s LFO-B : 150mm ² /s
Installation location		Indoor Ambient temperature: 0 to 40° C, RH 85% or below (no condensation), Height above sea level : 1000m or less. Place not exposed to direct sunlight. Place in an area free of corrosive or explosive gas or vapor.
Material	Casing	FC200
	Discharge pipe	SGP + SS
	Impeller	FCD450
	Main shaft	2.2 kW or less : S35C 3.7 kW or more : S45C
Shaft seal structure		Non-seal (mechanical seal-less)
Motor	Power source	3-phase 50/60/60Hz 200/200/220V 0.75~2.2kW 3-phase 50/60/60Hz 200/200/220V 3.7~5.5kW 3-phase 50/60/60Hz 400/400/440V
	Type	Totally enclosed fan-cooled indoor type
	Protection method	IP44
	Thermal class	F
	Rating	Continuous
Paint color		Munsell N1.5

*Do not use with freshwater.

Global standards

Type	Standards/Regulations	Output
		0.75kW-5.5kW
LFO-e	Top Runner efficiency (IE3 equivalent)	●
	GB3(GB18613-2020)	● ^{#1}

*1 GB certification label is attached as exclusive for GB standard. ● : Compliant

Table of Consumable Parts

Output (kW)	Bore diameter (mm)	Bearing		Oil seal	O-ring (for discharge pipes)
		Load side	Unload side		
0.75	50	6205ZZC3	6203ZZC3	G25355	G60
	65	6306ZZC3	6303ZZC3	G30456	
2.2	65	6306ZZC3	6303ZZC3	G30456	G75
	80				G90
3.7	65	6208ZZC3	6205ZZC3	VC40586	G75
	80				G90
5.5	80	6210ZZC3	6206ZZC3	VC50687	G90

Selection chart

●For low viscosity liquid (Values at kinematic viscosity 1mm²/s, specific gravity 1)

50Hz

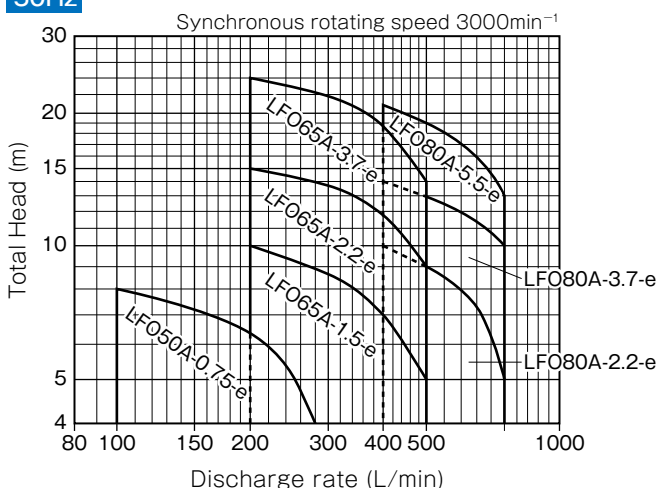

60Hz

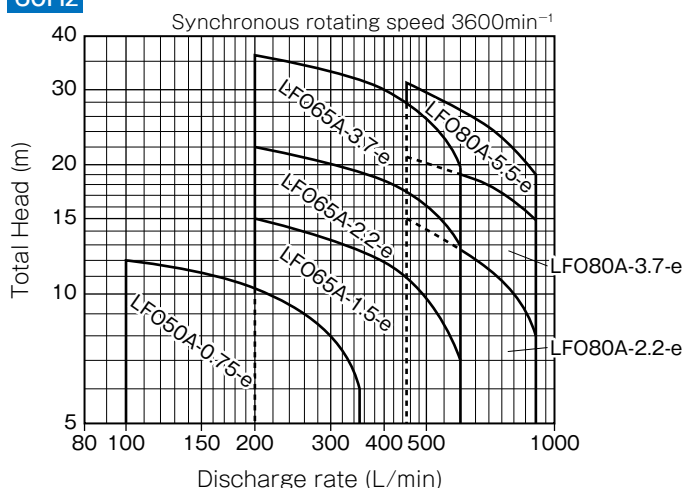

*Above selection chart may not be used depending on the kinematic viscosity and specific gravity of the liquid.
*Use pumps within the selection range. Do not operate with flow rate below the selection range.

■ Specification table

●For low viscosity liquid

Bore diameter (mm)	Frequency (Hz)	Type	Rated voltage (V)	Output (kW)	Rated current (A)	Starting current (A)	Discharge rate (L/min)	Total head (m)
50	50	LFO50A-0.75-35(50)-e	200	0.75	4.0	30	100-280	8-4
65		LFO65A-1.5-35(50)-e		1.5	6.5	66		10-5
		LFO65A-2.2-35(50)-e		2.2	9.3	84		15-9
80		LFO65A-3.7-35(50)-e	200/400	3.7	14.7/7.3	134/67	200-500	24-14
		LFO80A-2.2-35(50)-e	200	2.2	9.3	84	400-750	10-5
		LFO80A-3.7-35(50)-e	200/400	3.7	14.7/7.3	134/67		14-10
80	LFO80A-5.5-35(50)-e	200/400	5.5	22.0/11.5	155/77	400-750	21-13	
	50	LFO50A-0.75-35(50)-e	200/220	0.75	3.5/3.5	29/32	100-350	12-6
		LFO65A-1.5-35(50)-e		1.5	6.3/5.8	64/70		15-7
LFO65A-2.2-35(50)-e		2.2		8.4/7.9	73/80	22-13		
65	60	LFO65A-3.7-35(50)-e	200/220	3.7	13.7/12.9	116/130	200-600	36-20
		LFO65A-3.7-35(50)-e	400/440	3.7	6.8/6.5	58/65		36-20
		LFO80A-2.2-35(50)-e	200/220	2.2	8.4/7.9	73/80		15-8
80	60	LFO80A-3.7-35(50)-e	200/220	3.7	13.7/12.9	116/130	450-900	21-15
		LFO80A-3.7-35(50)-e		3.7	6.8/6.5	58/65		21-15
		LFO80A-5.5-35(50)-e	400/440	5.5	21.0/19.6	128/144		64/72

Note 1) The pump's rated current (current value listed on the pump nameplate) is the recommended current setting for protection device.
 ※Please inquire separately for China GB3 (GB18613-2020) compliant products.

■ Selection chart

●For high-viscosity liquid (Value at 150 mm²/s kinematic viscosity, specific gravity 1)

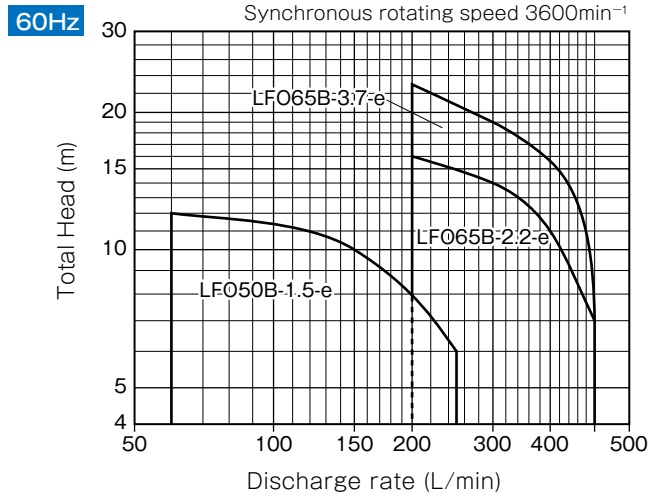
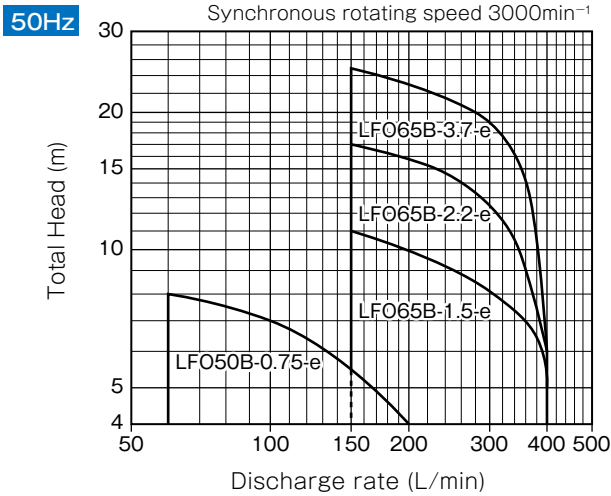

※Use pumps within the selection range. Do not operate with flow rate below the selection range.

■ Specification table

●For high-viscosity liquid

Bore diameter (mm)	Frequency (Hz)	Type	Rated voltage (V)	Output (kW)	Rated current (A)	Starting current (A)	Discharge rate (L/min)	Total head (m)
50	50	LFO50B-0.75-35(50)-e	200	0.75	4.0	30	60-200	8-4
65		LFO65B-1.5-35(50)-e		1.5	6.5	66		11-5
		LFO65B-2.2-35(50)-e		2.2	9.3	84		17-6
65		LFO65B-3.7-35(50)-e	200/400	3.7	14.7/7.3	134/67	150-400	25-6
50	60	LFO50B-1.5-35(50)-e	200/220	1.5	6.3/5.8	64/70	60-250	12-6
65		LFO65B-2.2-35(50)-e		2.2	8.4/7.9	73/80		16-7
		LFO65B-3.7-35(50)-e	200/220	3.7	13.7/12.9	116/130	200-500	23-8
	LFO65B-3.7-35(50)-e	400/440	3.7	6.8/6.5	58/65	23-8		

Note 1) The pump's rated current (current value listed on the pump nameplate) is the recommended current setting for protection device.
 ※Please inquire separately for China GB3 (GB18613-2020) compliant products.

Assembly drawing

Note 1) 3.7/5.5 kW motor wiring holes are shown in Figure 2.
Note 2) For 80 mm bore diameter, the outlet is a square flange (to be screwed-in) as shown in Figure 2 and 3.

Fig.1

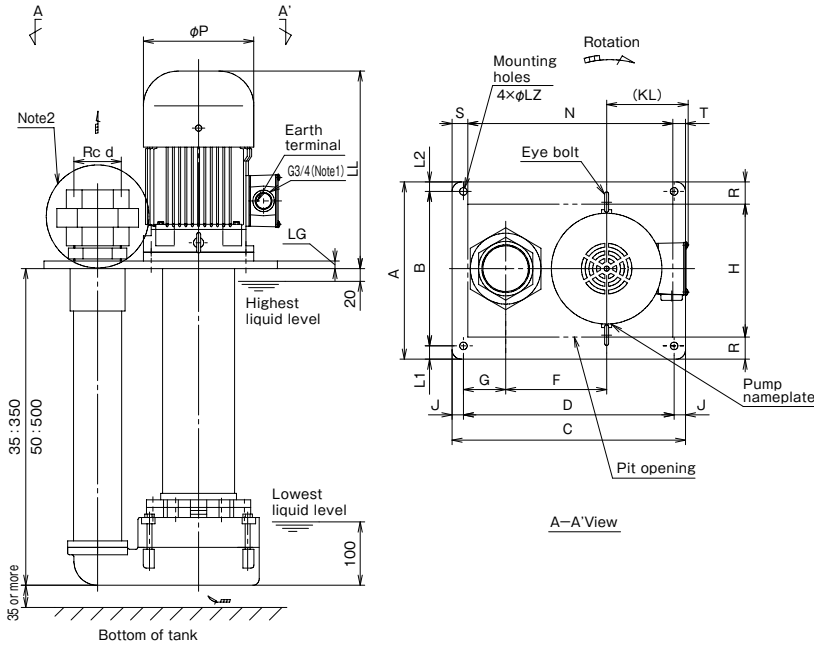

Fig.2

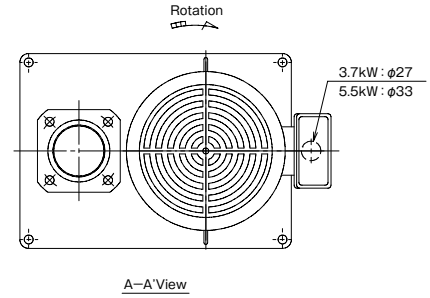
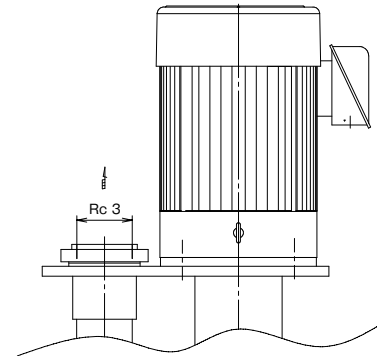

Fig.3



Dimensions

(Unit : mm)

Viscosity	Frequency (Hz)	Bore diameter	Type	d	A	B	C	D	F	G	H	L1	L2	J	LG	LL	KL	N	P	LZ	R	S	T	Approx. mass(kg)	
For low viscosity	50/60	50	LFO50A-0.75-35	-e	2	260	224	300	264	145	37	170	18	18	18	12	252	115	270	140	12	45	10	20	34
			LFO50A-0.75-50	-e	2	260	224	300	264	145	37	37	170	18	18	18	12	252	115	270	140	12	45	10	20
		65	LFO65A-1.5-35	-e	2 1/2	280	244	370	334	160	67	210	18	18	18	12	312	130	325	175	12	35	25	20	50
			LFO65A-1.5-50	-e	2 1/2	280	244	370	334	160	67	210	18	18	18	12	312	130	325	175	12	35	25	20	52
		80	LFO80A-2.2-35	-e	2 1/2	310	280	420	390	180	85	250	15	15	15	12	312	130	360	175	15	30	30	30	56
			LFO80A-2.2-50	-e	2 1/2	310	280	420	390	180	85	250	15	15	15	12	312	130	360	175	15	30	30	30	58
	50/60	65	LFO65A-3.7-35	-e	2 1/2	310	280	420	390	180	85	250	15	15	15	12	377	165	360	235	15	30	30	30	81
			LFO65A-3.7-50	-e	2 1/2	310	280	420	390	180	85	250	15	15	15	12	377	165	360	235	15	30	30	30	83
			LFO80A-5.5-35	-e	3	330	300	460	430	215	85	270	15	15	15	16	434	212	400	264	15	30	30	30	109
For high viscosity	50	50	LFO50B-0.75-35	-e	2	260	224	300	264	145	37	170	18	18	18	12	252	115	270	140	12	45	10	20	34
			LFO50B-0.75-50	-e	2	260	224	300	264	145	37	37	170	18	18	18	12	252	115	270	140	12	45	10	20
	60	50	LFO50B-1.5-35	-e	2	260	224	300	264	145	37	170	18	18	18	12	312	130	270	175	12	45	10	22	40
			LFO50B-1.5-50	-e	2	260	224	300	264	145	37	170	18	18	18	12	312	130	270	175	12	45	10	22	42
	50/60	65	LFO65B-1.5-35	-e	2 1/2	280	244	370	334	160	67	210	18	18	18	12	312	130	325	175	12	35	25	20	50
			LFO65B-1.5-50	-e	2 1/2	280	244	370	334	160	67	210	18	18	18	12	312	130	325	175	12	35	25	20	52
			LFO65B-2.2-35	-e	2 1/2	310	280	420	390	180	85	250	15	15	15	12	312	130	360	175	15	30	30	30	56
	50/60	60	LFO65B-2.2-50	-e	2 1/2	310	280	420	390	180	85	250	15	15	15	12	312	130	360	175	15	30	30	30	58
			LFO65B-2.2-35	-e	2 1/2	280	244	370	334	160	67	210	18	18	18	12	312	130	325	175	12	35	25	20	51
50/60	60	LFO65B-2.2-50	-e	2 1/2	280	244	370	334	160	67	210	18	18	18	12	312	130	325	175	12	35	25	20	53	
		LFO65B-3.7-35	-e	2 1/2	310	280	420	390	180	85	250	15	15	15	12	377	165	360	235	15	30	30	30	81	
50/60	60	LFO65B-3.7-50	-e	2 1/2	310	280	420	390	180	85	250	15	15	15	12	377	165	360	235	15	30	30	30	83	

Detailed drawing of the terminal box

●Output 2.2 kW or less

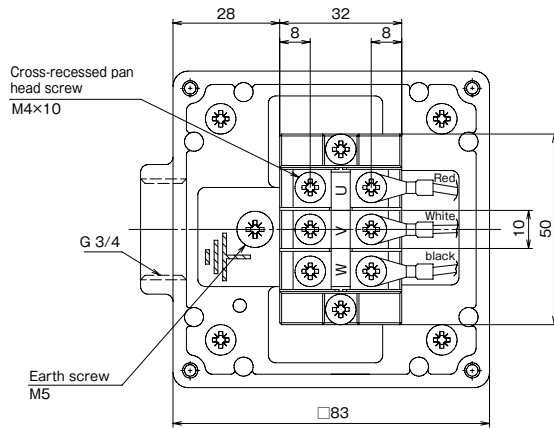

●Output 3.7 kW or more

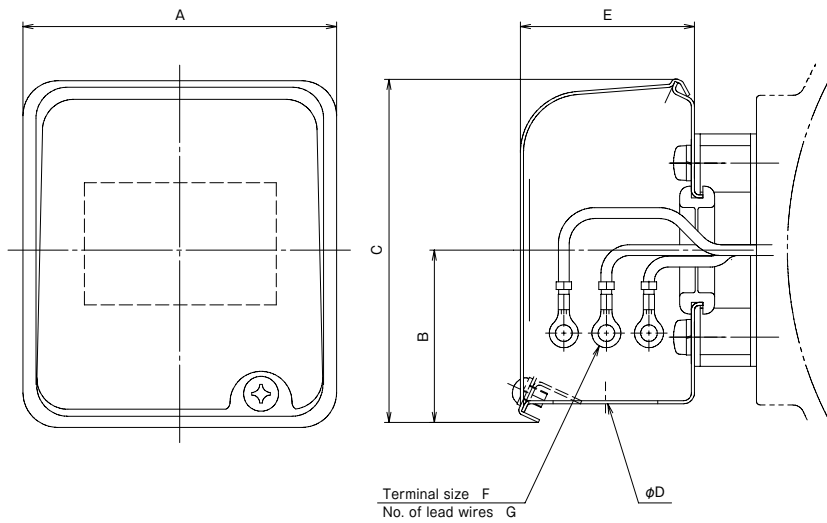

Terminal box

Output (kW)	A	B	C	D	E	F	G
3.7	82	45	89	27	46	1.25-4	9
5.5	126	68	133	33	60	2-5	12

Connection diagram

●Output 3.7 kW

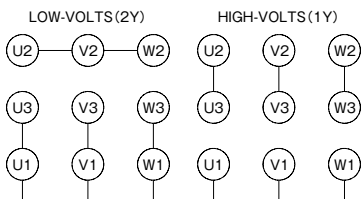

●Output 5.5 kW

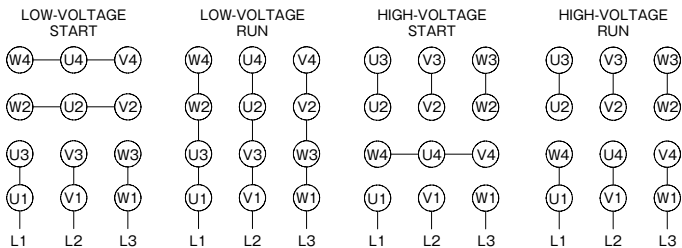

Sectional drawing

●LFO50-e

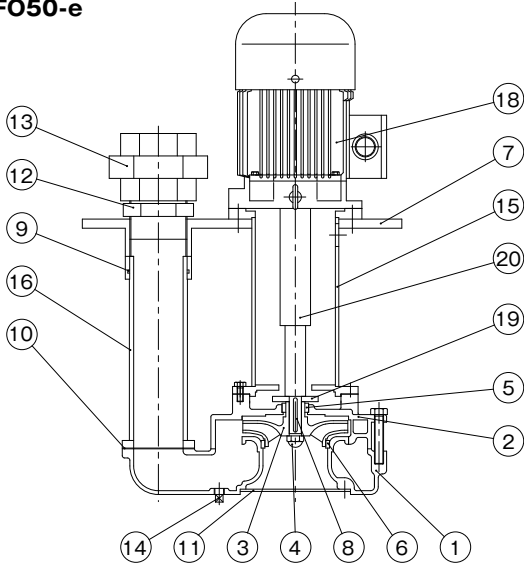

●LFO65-e

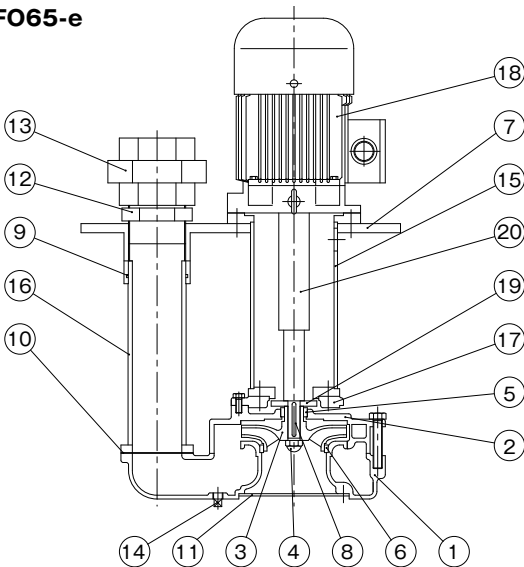

●LFO80-e

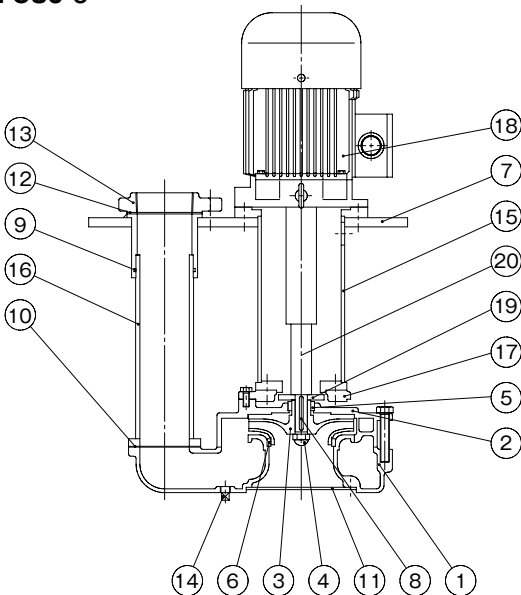

●LFO50-e/65-e

No.	Part name	Qty	Material
1	Casing	1	FC200
2	Casing cover	1	FC200
3	Impeller	1	FCD450
4	Impeller nut	1	SUS304
5	Discharge bushing	1	SUS304
6	Wearing ring	1	SUS304
7	Common bed	1	SS400
8	Key	1	S35C
9	O-ring	1	NBR
10	Sheet packing	1	Three sheet
11	Strainer	1	SS400
12	Nipple	1	FC
13	Union	1	FC
14	Plug	1	SS400
15	Protection pipe	1	SGP + SS
16	Discharge pipe	1	SGP + SS
17	Connection flange ^{Note 1}	1	FC200
18	Motor	1	
19	Deflector	1	SS400
20	Main shaft	1	S35C(2.2kW or less)/ S45C(3.7kW or more)

Note 1) LFO-65-e only.

Note 2) The materials in the table above are equivalents.

Note 3) Structure and other details are subject to change without notice.

●LFO80-e

No.	Part name	Qty	Material
1	Casing	1	FC200
2	Casing cover	1	FC200
3	Impeller	1	FCD450
4	Impeller nut	1	SUS304
5	Discharge bushing	1	SUS304
6	Wearing ring	1	SUS304
7	Common bed	1	SS400
8	Key	1	S35C
9	O-ring	1	NBR
10	Sheet packing	1	Three sheet
11	Strainer	1	SS400
12	Sheet packing	1	Three sheet
13	Companion flange	1	FC200
14	Plug	1	SS400
15	Protection pipe	1	SGP + SS
16	Discharge pipe	1	SGP + SS
17	Connection flange	1	FC200
18	Motor	1	
19	Deflector	1	SS400
20	Main shaft	1	S35C(2.2kW or less)/ S45C(3.7kW or more)

Note 1) The materials in the table above are equivalents.

Note 2) Structure and other details are subject to change without notice.

Features

- ① With a non-seal (mechanical seal-less) structure, it is easy to maintain.
- ② A motor is highly compact and light weight!!
(Compared with our product: height of the motor is reduced by 20 mm).
- ③ The lineup including the models complying with global standards by supporting efficiency and other regulations.
 - Japan : Top Runner efficiency
 - Europe : IE3 efficiency, CE marking (EU Directive)
RoHS Directive (2011/65/EU), 10 restricted substances.
 - USA : NEMA Premium efficiency (IE3 efficiency), UL standards (safety)
 - Korea : Energy Efficiency Label and Standard Program (KC Standards, IE3)
 - Canada : CSA standard (efficiency), CSA standard (safety)
 - China : GB3 (GB18613-2020)
- ④ These are energy saving pumps with high efficiency impellers and IE3 efficiency motors.
- ⑤ Highly abrasion-resistant SiC bearings are adopted in the pump bearings.
- ⑥ Measures against air suction into the pump are taken when the liquid level lowers.
- ⑦ Energy-saving operation by inverter control (flow rate adjustment etc..) is possible.



Please note that the paint color, etc. of the actual unit may partially differ from the photo.

Non-seal structure

TERAL's original "non-seal" structure allows coolant to flow from a narrow clearance without using a seal between the pump section and the motor section.

The advantages of a non-seal pump

- 1 No trouble such as coolant leaks.**
Helps cut down on running costs.
- 2 Prevents air entrainment.**
Reduces initial problems.
- 3 Not easily affected by a small quantity of liquid or shut-off operations.**
Enables a flexible operation system.

※What is non-seal structure?

This structure inwardly releases coolant by depressurizing through a narrow clearance without the use of a mechanical seal.

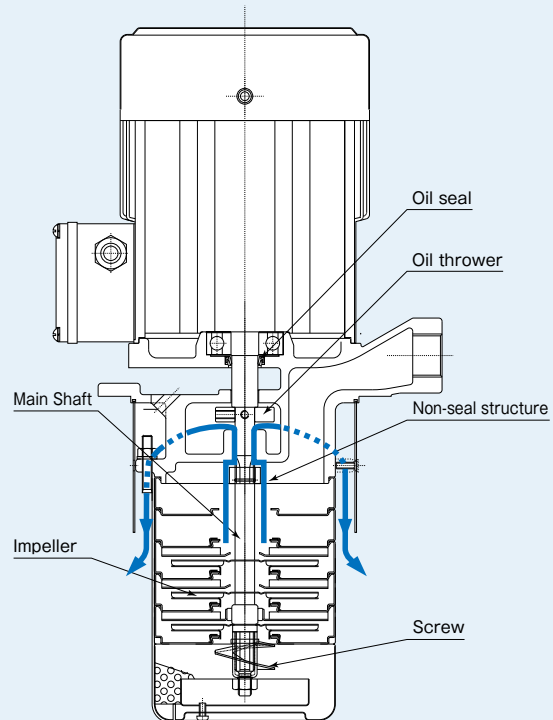

Description of types

LBK 2 - 60 / 3 -F -e

① ② ③ ④ ⑤ ⑥

- ① Model
 ② Nominal flow rate [m³/h]
 ③ Number of casings ×10
 ④ Number of impellers
 ⑤ ID code H: available for high viscous liquid (models with 8 impellers only)
 (*Other models than the above can be used for high viscous liquid as standard.)
 F: exclusive for 50Hz
 None: Models other than the above
 ⑥ Motor efficiency
 -e : Top Runner efficiency (equivalent to IE3)
 -7W: Equipped with NEMA Premium efficiency, UL/CSA certified motor (Output less than 0.75kW complies to safety standards only)
 -KS: Equipped with Korea Energy Efficiency Label and Standard Program compliant motor (IE3)

Standard Specification

Used liquid	Property of liquid	Grinding liquid, cutting liquid, etc. after secondary treatment *1
	Temperature	-10 to 90 °C (No frozen liquid)
Allowable kinematic viscosity *2		75mm ² /S
Installation location		Indoor Ambient temperature: -20 to 40 °C, RH 85% or below (no condensation). Height above sea level : 1000m or less. Place not exposed to direct sunlight. Place in an area free of corrosive or explosive gas or vapor.
Material	Discharge casing	FC200
	Casing Outer sleeve	SUS304
	Suction casing	SUS304
	Impeller	SUS304
	Main shaft (motor side+pump side)	S45C+SUS431
Shaft seal structure		Non-seal (mechanical seal-less)
Motor	Type	Totally enclosed fan-cooled indoor type
	Protection method	IP54
	Power source	3-phase 50/60/60Hz 200/200/230V *3
	Thermal class	F *4
	Number of poles	2P
Paint color	Pump	Munsell N1
	Motor	Black

*1 If the liquid contains hard sludge, such as abrasive powder, ground powder, or ground diamond grains, the service life might be shortened. Please set up a filter (magnet filter or paper filter, etc.). Take note that special liquid such as water, printing liquid or acid liquid cannot be used. Contact us for other special liquid (pure water, alkali-acid liquid, ceramic, etc.).

*2 Allowable kinematic viscosity for LBK2-□/8-e is 1mm²/s.
 Allowable kinematic viscosity of -7W type is 1mm²/s.

*3 Korea Energy Efficiency Label and Standard Program / NEMA Premium efficiency (IE3), UL Standards (safety) : 3-phase 60Hz 200V-230V
 GB18613-2020: 3-phase 50Hz 200V, 50Hz 380V

*4 Thermal class of -7W type is class A.

Global standards

Type	Standards/Regulations	Output			
		50Hz		60Hz	
		0.35kW -0.55kW	0.8kW -1.8kW	0.55kW	0.75kW -2.2kW
LBK-e	Top Runner efficiency (IE3 equivalent)	—	●	—	●
	CE Marking	●	●	●	●
	GB3(GB18613-2020)	●	●*1	X	
LBK-7W	NEMA Premium efficiency	X		—	●
	UL Standards (safety)	X		●	●
	Canada CSA standard (efficiency)	X		—	●
	Canada CSA standard (safety)	X		●	●
LBK-KS	Energy Efficiency Label and Standard Program (IE3)	X		—	●

*1 GB certification label is attached as exclusive for GB standard. ● : Compliant
 — : Ineligible

Table of Consumable Parts

●-e type

Frequency [Hz]	Output [kW]	Bearing		Oil seal	
		Load side	Unload side	Load side	Unload side
50/60	0.35/0.55	6303ZZC3	6201ZZC3	VC16244	-
50/60	0.55/0.75				
50/60	0.8/1.1				
50	1.1				
50/60	1.2/1.5	6205ZZC3	6304ZZC3	VC20407	
50/60	1.8/2.2				

●-7W type

Frequency [Hz]	Output [kW]	Bearing		Oil seal	
		Load side	Unload side	Load side	Unload side
60	0.55	6303ZZC3	6201ZZC3	VC16244	-
60	0.75				
60	1.1				
60	1.5	6205ZZC3	6304ZZC3		
60	2.2				

●-KS type

Frequency [Hz]	Output [kW]	Bearing		Oil seal	
		Load side	Unload side	Load side	Unload side
60	0.75	6303ZZC3	6201ZZC3	VC16244	-
60	1.1				
60	1.5				
60	2.2	6205ZZC3	6304ZZC3		

Special specification

Motor modifications	Change of terminal box position
---------------------	---------------------------------

Selection chart

(Values at kinematic viscosity 1mm²/s, specific gravity 1)

●Pressure type LBK2

50Hz

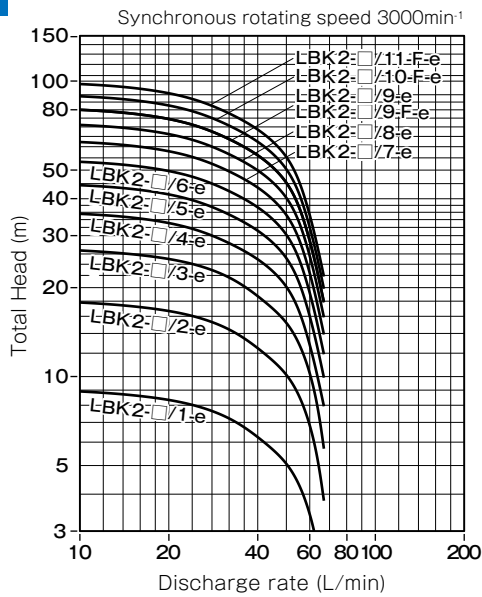

60Hz

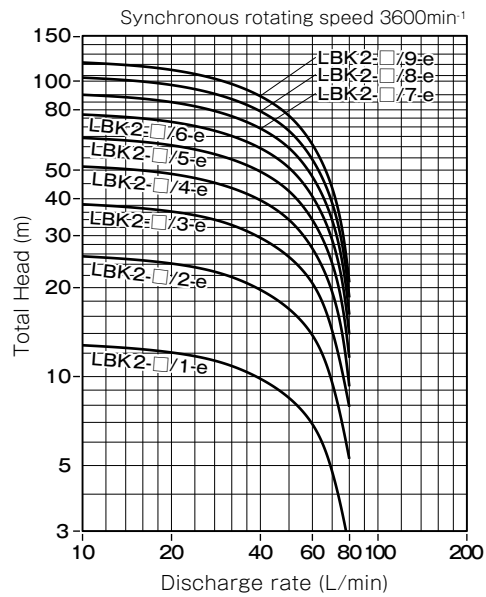

●Flow type LBK4

50Hz

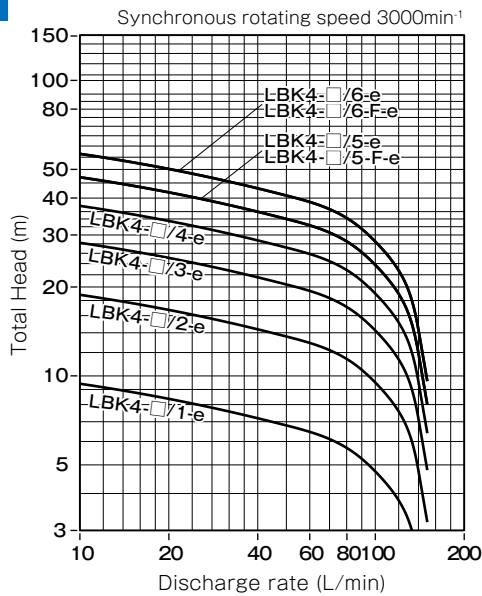

60Hz

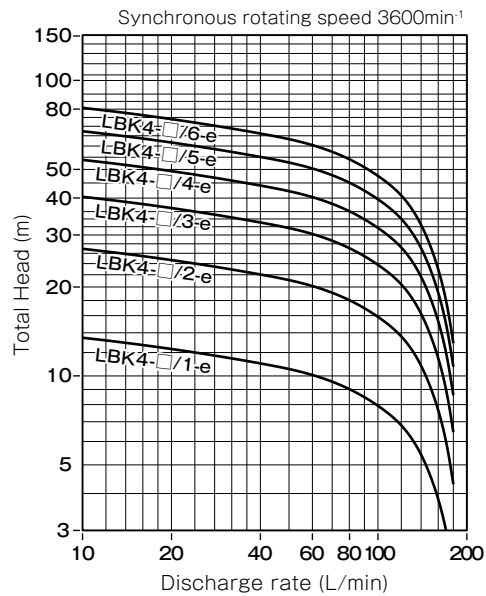

※ The specified flow may not be achieved in the large water volume range depending on the discharge pipe diameter.
 ※ Above selection chart (-e) is also available for -KS/-7W type.

Selection chart

(Values at kinematic viscosity 75mm²/s, specific gravity 0.86)

● Pressure type LBK2

50Hz

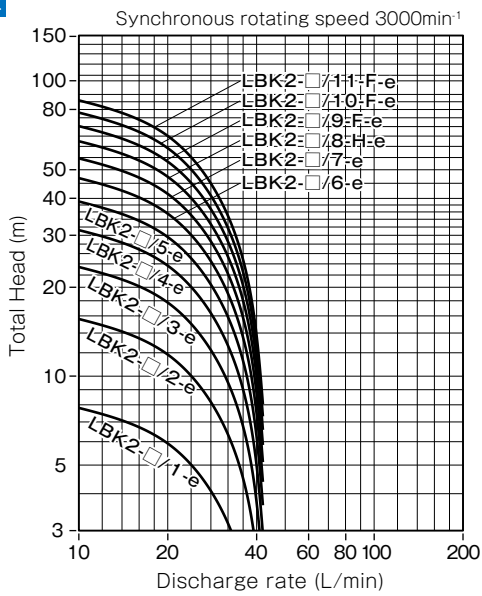

60Hz

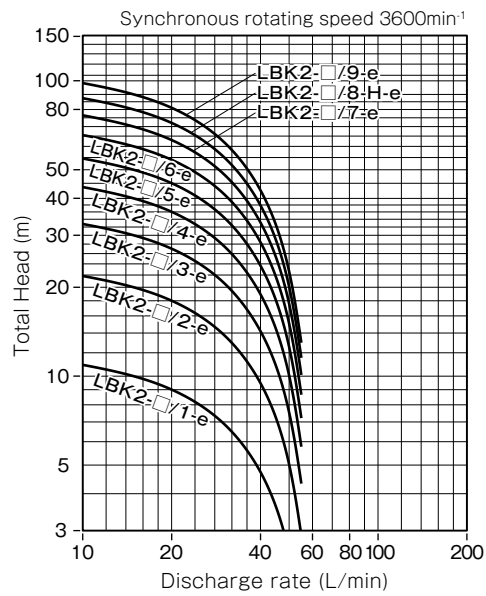

● Flow type LBK4

50Hz

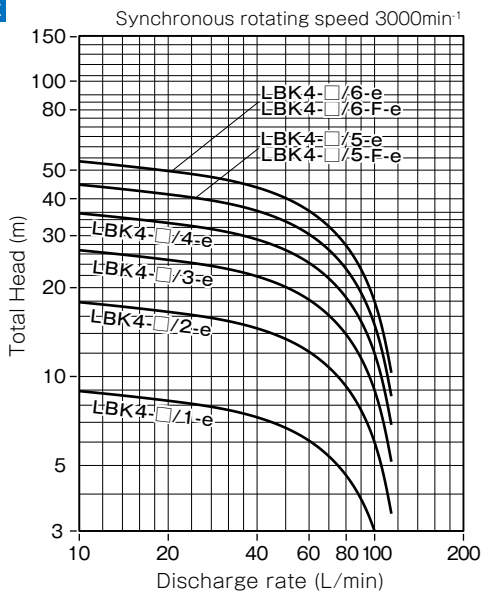

60Hz

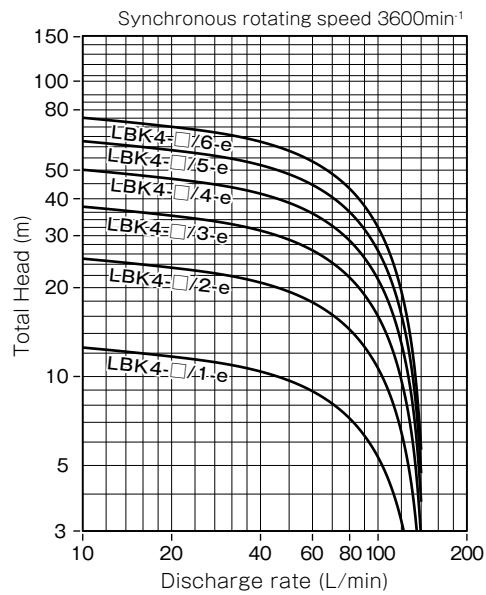

※ The specified flow may not be achieved in the large water volume range depending on the discharge pipe diameter.
 ※ Above selection chart (-e) is also available for -KS/-7W type.

■ Specification table

●-e type

Type	50Hz						60Hz					
	Rated voltage (V)	Output (kW)	Rated current (A)	Starting current (A)	Discharge rate (L/min)	Total head (m)	Rated voltage (V)	Output (kW)	Rated current (A)	Starting current (A)	Discharge rate (L/min)	Total head (m)
LBK2-□/1-e	200	0.35	3.5	16.4	42	6	200/230	0.55	3.5/3.5	15.5/17.9	50	8.4
LBK2-□/2-e	200	0.35	3.5	16.4	42	12	200/230	0.55	3.5/3.5	15.5/17.9	50	16.9
LBK2-□/3-e	200	0.35	3.5	16.4	42	18	200/230	0.55	3.5/3.5	15.5/17.9	50	25.4
LBK2-□/4-e	200	0.55	3.9	26	42	24	200/230	0.75	4.1/4.1	25.0/28.5	50	33.9
LBK2-□/5-e	200	0.55	3.9	26	42	30	200/230	0.75	4.1/4.1	25.0/28.5	50	42.4
LBK2-□/6-e	200	0.8	6.3	37.9	42	36	200/230	1.1	6.0/6.0	35.3/40.6	50	50.9
LBK2-□/7-e	200	0.8	6.3	37.9	42	42	200/230	1.1	6.0/6.0	35.3/40.6	50	59.3
LBK2-□/8-e	200	0.8	6.3	37.9	25	62.5	200/230	1.1	6.0/6.0	35.3/40.6	30	88.9
LBK2-□/8-H-e	200	1.2	6.2	47	42	48	200/230	1.5	7.8/7.0	41.0/47.6	50	67.8
LBK2-□/9-e	200	1.2	6.2	47	42	54	200/230	1.5	7.8/7.0	41.0/47.6	50	76.3
LBK2-□/9-F-e	200	1.1	6.2	35	42	54	-	-	-	-	-	-
LBK2-□/10-F-e	200	1.1	6.2	35	42	60	-	-	-	-	-	-
LBK2-□/11-F-e	200	1.1	6.2	35	42	66	-	-	-	-	-	-
LBK4-□/1-e	200	0.35	3.5	16.4	85	5.5	200/230	0.55	3.5/3.5	15.5/17.9	100	7.9
LBK4-□/2-e	200	0.35	3.5	16.4	85	11	200/230	0.55	3.5/3.5	15.5/17.9	100	15.9
LBK4-□/3-e	200	0.55	3.9	26	85	16.5	200/230	0.75	4.1/4.1	25.0/28.5	100	23.8
LBK4-□/4-e	200	0.8	6.3	37.9	85	21.9	200/230	1.1	6.0/6.0	35.3/40.6	100	31.7
LBK4-□/5-e	200	1.2	6.2	47	85	27.4	200/230	1.5	7.8/7.0	41.0/47.6	100	39.6
LBK4-□/6-e	200	1.8	7.4	83	85	32.9	200/230	2.2	10.5/9.7	78.0/82.6	100	47.6
LBK4-□/5-F-e	200	1.1	6.2	35	85	27.4	-	-	-	-	-	-
LBK4-□/6-F-e	200	1.1	6.2	35	85	32.9	-	-	-	-	-	-

Note 1) Discharge rate and total head are the values obtained in the test with a liquid viscosity of 1mm²/s (same as fresh water at normal temperature).
 Note 2) The pump's current (current value listed on the pump nameplate) is the recommended current setting for protection device.

●-e (50Hz 380V)

Type	50Hz					
	Rated voltage (V)	Output (kW)	Rated current (A)	Starting current (A)	Discharge rate (L-min)	Total head (m)
LBK2-□/1-e	380	0.35	1.7	9.1	42	6
LBK2-□/2-e	380	0.35	1.7	9.1	42	12
LBK2-□/3-e	380	0.35	1.7	9.1	42	18
LBK2-□/4-e	380	0.55	2.2	14	42	24
LBK2-□/5-e	380	0.55	2.2	14	42	30
LBK2-□/6-e	380	0.8	2.9	17.2	42	36
LBK2-□/7-e	380	0.8	2.9	17.2	42	42
LBK2-□/8-e	380	0.8	2.9	17.2	25	62.5
LBK2-□/8-H-e	380	1.2	3.6	31.9	42	48
LBK2-□/9-e	380	1.2	3.6	31.9	42	54
LBK2-□/9-F-e	380	1.1	3.6	19.6	42	54
LBK2-□/10-F-e	380	1.1	3.6	19.6	42	60
LBK2-□/11-F-e	380	1.1	3.6	19.6	42	66
LBK4-□/1-e	380	0.35	1.7	9.1	85	5.5
LBK4-□/2-e	380	0.35	1.7	9.1	85	11
LBK4-□/3-e	380	0.55	2.2	14	85	16.5
LBK4-□/4-e	380	0.8	2.9	17.2	85	21.9
LBK4-□/5-e	380	1.2	3.6	31.9	85	27.4
LBK4-□/6-e	380	1.8	4.1	42.7	85	32.9
LBK4-□/5-F-e	380	1.1	3.6	19.6	85	27.4
LBK4-□/6-F-e	380	1.1	3.6	19.6	85	32.9

Note 1) Discharge rate and total head are the values obtained in the test with a liquid viscosity of 1mm²/s (same as fresh water at normal temperature).
 Note 2) The pump's current (current value listed on the pump nameplate) is the recommended current setting for protection device.

●-7W type

Type	60Hz					
	Rated voltage (V)	Output (kW)	Rated current (A)	Starting current (A)	Discharge rate (L-min)	Total head (m)
LBK2-□-1-7W	200-230	0.55	3.1-3.1	15.5-17.9	50	8.4
LBK2-□-2-7W	200-230	0.55	3.1-3.1	15.5-17.9	50	16.9
LBK2-□-3-7W	200-230	0.55	3.1-3.1	15.5-17.9	50	25.4
LBK2-□-4-7W	200-230	0.75	4.0-4.0	25.0/28.5	50	33.9
LBK2-□-5-7W	200-230	0.75	4.0-4.0	25.0/28.5	50	42.4
LBK2-□-6-7W	200-230	1.1	5.9-5.9	35.3/40.6	50	50.9
LBK2-□-7-7W	200-230	1.1	5.9-5.9	35.3/40.6	50	59.3
LBK2-□-8-7W	200-230	1.1	5.9-5.9	35.3/40.6	30	88.9
LBK2-□-8-H-7W	200-230	1.5	6.4-5.8	41.0-47.6	50	67.8
LBK2-□-9-7W	200-230	1.5	6.4-5.8	41.0-47.6	50	76.3
LBK4-□-1-7W	200-230	0.55	3.1-3.1	15.5-17.9	100	7.9
LBK4-□-2-7W	200-230	0.55	3.1-3.1	15.5-17.9	100	15.9
LBK4-□-3-7W	200-230	0.75	4.0-4.0	25.0/28.5	100	23.8
LBK4-□-4-7W	200-230	1.1	5.9-5.9	35.3/40.6	100	31.7
LBK4-□-5-7W	200-230	1.5	6.4-5.8	41.0-47.6	100	39.6
LBK4-□-6-7W	200-230	2.2	9.1-8.5	78.0-82.6	100	47.6

Note 1) Discharge rate and total head are the values obtained in the test with a liquid viscosity of 1mm²/s (same as fresh water at normal temperature).

Note 2) The pump's current (current value listed on the pump nameplate) is the recommended current setting for protection device.

●-KS type

Type	60Hz					
	Rated voltage (V)	Output (kW)	Rated current (A)	Starting current (A)	Discharge rate (L-min)	Total head (m)
LBK2-□-4-KS	200-230	0.75	4.1-4.1	25.0-28.5	50	33.9
LBK2-□-5-KS	200-230	0.75	4.1-4.1	25.0-28.5	50	42.4
LBK2-□-6-KS	200-230	1.1	6.0-6.0	35.3-40.6	50	50.9
LBK2-□-7-KS	200-230	1.1	6.0-6.0	35.3-40.6	50	59.3
LBK2-□-8-KS	200-230	1.1	6.0-6.0	35.3-40.6	30	88.9
LBK2-□-8-H-KS	200-230	1.5	7.8-7.0	41.0-47.6	50	67.8
LBK2-□-9-KS	200-230	1.5	7.8-7.0	41.0-47.6	50	76.3
LBK4-□-3-KS	200-230	0.75	4.1-4.1	25.0-28.5	100	23.8
LBK4-□-4-KS	200-230	1.1	6.0-6.0	35.3-40.6	100	31.7
LBK4-□-5-KS	200-230	1.5	7.8-7.0	41.0-47.6	100	39.6
LBK4-□-6-KS	200-230	2.2	10.5-9.7	78.0-82.6	100	47.6

Note 1) Discharge rate and total head are the values obtained in the test with a liquid viscosity of 1mm²/s (same as fresh water at normal temperature).

Note 2) The pump's current (current value listed on the pump nameplate) is the recommended current setting for protection device.

■ Assembly drawing

Fig.1

●Output: 1.1kW (50/60Hz) or less

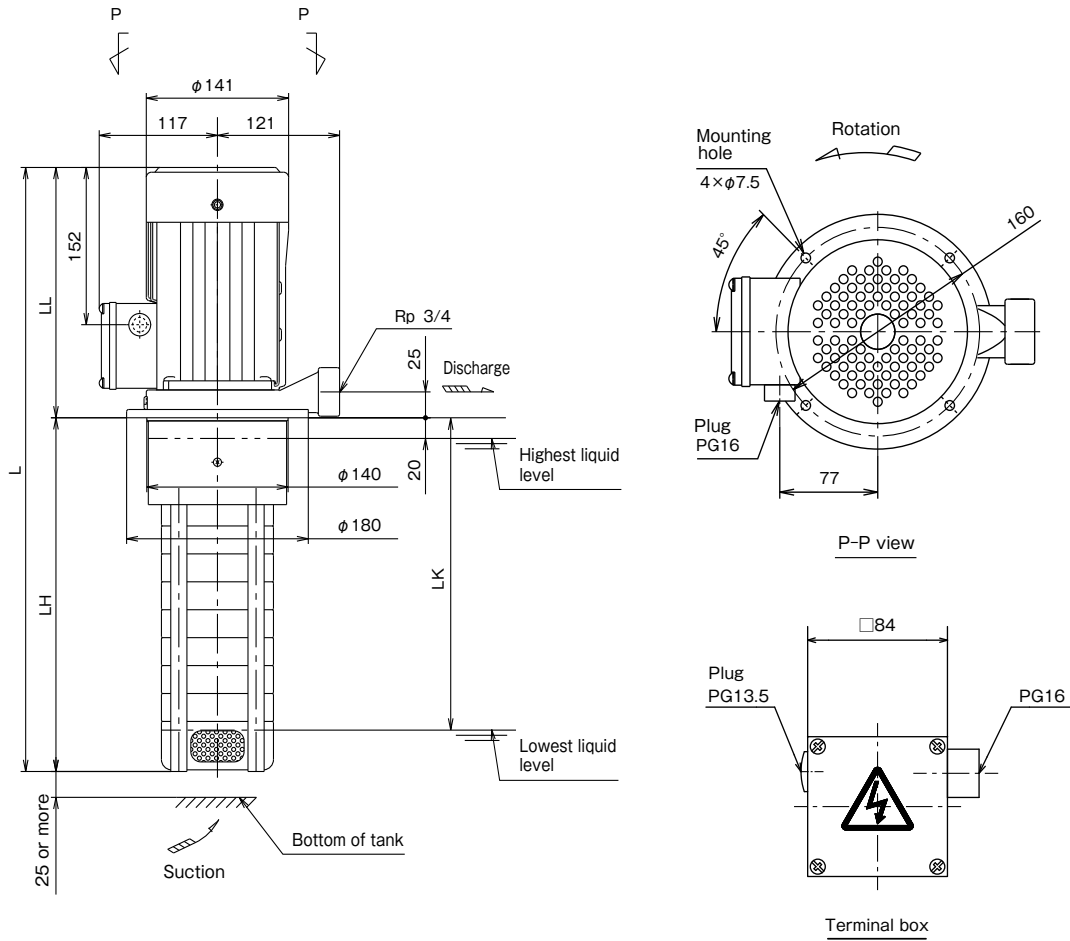

■ Dimensions

(Unit : mm)

Type	Fig.	L	LL	LH	LK	Approx. mass (kg)
LBK2-30/1-□	1	354	201	153	113	15
LBK2-40/1-□	1	372	201	171	131	15
LBK2-50/1-□	1	390	201	189	149	15
LBK2-60/1-□	1	408	201	207	167	15
LBK2-30/2-□	1	354	201	153	113	15
LBK2-40/2-□	1	372	201	171	131	15
LBK2-50/2-□	1	390	201	189	149	15
LBK2-60/2-□	1	408	201	207	167	15
LBK2-70/2-□	1	426	201	225	185	15
LBK2-80/2-□	1	444	201	243	203	16
LBK2-90/2-□	1	462	201	261	221	16
LBK2-100/2-□	1	480	201	279	239	16
LBK2-110/2-□	1	498	201	297	257	16
LBK2-30/3-□	1	354	201	153	113	15
LBK2-40/3-□	1	372	201	171	131	15
LBK2-50/3-□	1	390	201	189	149	15
LBK2-60/3-□	1	408	201	207	167	15
LBK2-70/3-□	1	426	201	225	185	15
LBK2-80/3-□	1	444	201	243	203	16
LBK2-90/3-□	1	462	201	261	221	16
LBK2-100/3-□	1	480	201	279	239	16
LBK2-110/3-□	1	498	201	297	257	16
LBK2-40/4-■	1	412	241	171	131	15
LBK2-50/4-■	1	430	241	189	149	15
LBK2-60/4-■	1	448	241	207	167	15
LBK2-70/4-■	1	466	241	225	185	15
LBK2-80/4-■	1	484	241	243	203	16
LBK2-90/4-■	1	502	241	261	221	16
LBK2-100/4-■	1	520	241	279	239	16
LBK2-110/4-■	1	538	241	297	257	16
LBK2-50/5-■	1	430	241	189	149	15
LBK2-60/5-■	1	448	241	207	167	15
LBK2-70/5-■	1	466	241	225	185	16
LBK2-80/5-■	1	484	241	243	203	16
LBK2-90/5-■	1	502	241	261	221	16
LBK2-100/5-■	1	520	241	279	239	16
LBK2-110/5-■	1	538	241	297	257	16
LBK2-60/6-■	1	448	241	207	167	15
LBK2-70/6-■	1	466	241	225	185	16
LBK2-80/6-■	1	484	241	243	203	16
LBK2-90/6-■	1	502	241	261	221	16
LBK2-100/6-■	1	520	241	279	239	16
LBK2-110/6-■	1	538	241	297	257	16
LBK2-70/7-■	1	466	241	225	185	16
LBK2-80/7-■	1	484	241	243	203	16
LBK2-90/7-■	1	502	241	261	221	16
LBK2-100/7-■	1	520	241	279	239	16
LBK2-110/7-■	1	538	241	297	257	16
LBK2-80/8-■	1	484	241	243	203	16
LBK2-90/8-■	1	502	241	261	221	16
LBK2-100/8-■	1	520	241	279	239	16
LBK2-110/8-■	1	538	241	297	257	16
LBK2-90/9-F-e	1	502	241	261	221	16
LBK2-100/9-F-e	1	520	241	279	239	16
LBK2-110/9-F-e	1	538	241	297	257	17
LBK2-100/10-F-e	1	520	241	279	239	16
LBK2-110/10-F-e	1	538	241	297	257	17
LBK2-110/11-F-e	1	538	241	297	257	17

(Unit : mm)

Type	Fig.	L	LL	LH	LK	Approx. mass (kg)
LBK4-20/1-□	1	354	201	153	113	14
LBK4-30/1-□	1	381	201	180	140	14
LBK4-40/1-□	1	408	201	207	167	14
LBK4-50/1-□	1	435	201	234	194	15
LBK4-60/1-□	1	462	201	261	221	15
LBK4-20/2-□	1	354	201	153	113	14
LBK4-30/2-□	1	381	201	180	140	14
LBK4-40/2-□	1	408	201	207	167	15
LBK4-50/2-□	1	435	201	234	194	15
LBK4-60/2-□	1	462	201	261	221	15
LBK4-70/2-□	1	489	201	288	248	15
LBK4-80/2-□	1	516	201	315	275	15
LBK4-90/2-□	1	543	201	342	302	16
LBK4-30/3-■	1	421	241	180	140	14
LBK4-40/3-■	1	448	241	207	167	15
LBK4-50/3-■	1	475	241	234	194	15
LBK4-60/3-■	1	502	241	261	221	15
LBK4-70/3-■	1	529	241	288	248	15
LBK4-80/3-■	1	556	241	315	275	16
LBK4-40/4-■	1	448	241	207	167	15
LBK4-50/4-■	1	475	241	234	194	15
LBK4-60/4-■	1	502	241	261	221	15
LBK4-70/4-■	1	529	241	288	248	15
LBK4-80/4-■	1	556	241	315	275	16
LBK4-90/4-■	1	583	241	342	302	16
LBK4-50/5-F-e	1	475	241	234	194	15
LBK4-60/5-F-e	1	502	241	261	221	15
LBK4-70/5-F-e	1	529	241	288	248	16
LBK4-80/5-F-e	1	556	241	315	275	16
LBK4-60/6-F-e	1	502	241	261	221	15
LBK4-70/6-F-e	1	529	241	288	248	16
LBK4-80/6-F-e	1	556	241	315	275	16

Note 1) "□" in pump type can be -e/-7W.

Note 2) "■" in pump type can be -e/-KS/-7W.

Assembly drawing

Fig.2

●Output: 1.2kW (50Hz), 1.5kW (60Hz) or more

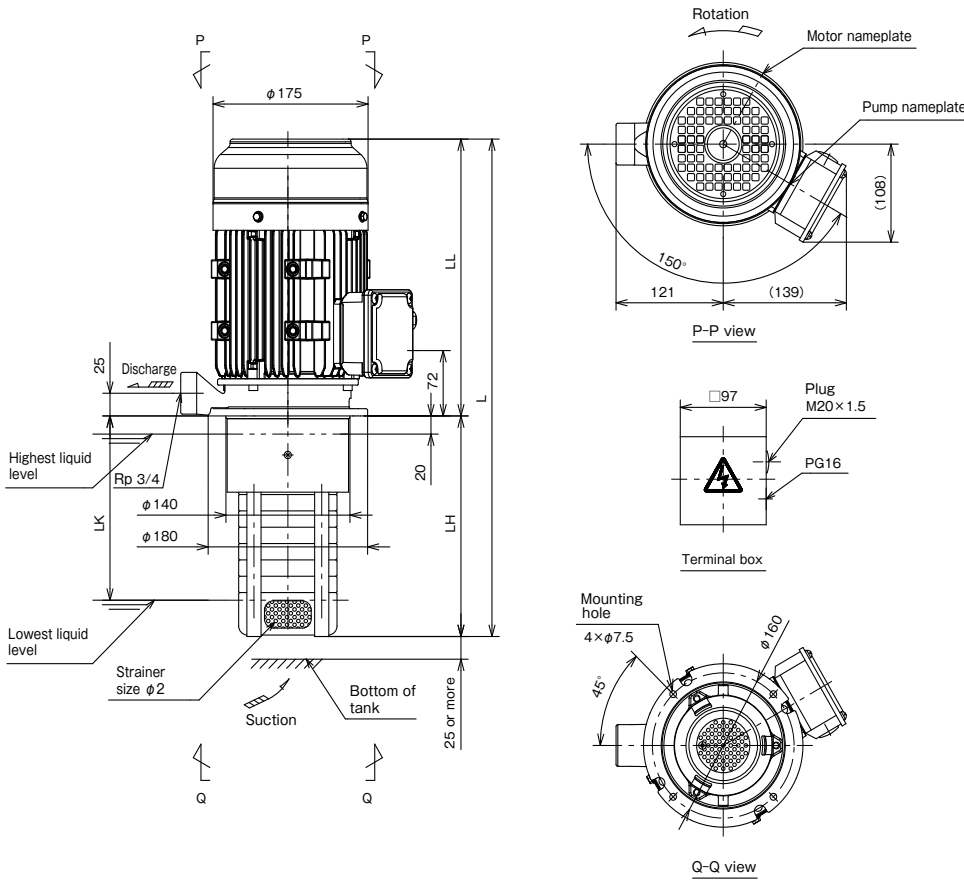

Dimensions

(Unit : mm)

Type	Fig.	L	LL	LH	LK	Approx. mass (kg)
LBK2-80/8-H-■	2	548	305	243	203	23
LBK2-90/8-H-■	2	566	305	261	221	23
LBK2-90/9-■	2	566	305	261	221	23

(Unit : mm)

Type	Fig.	L	LL	LH	LK	Approx. mass (kg)
LBK4-50/5-■	2	539	305	234	194	22
LBK4-60/5-■	2	566	305	261	221	22
LBK4-60/6-■	2	566	305	261	221	25
LBK4-70/6-■	2	593	305	288	248	26
LBK4-80/6-■	2	620	305	315	275	26
LBK4-90/6-■	2	647	305	342	302	26

Note 1) "■" in pump type can be any one of -e/-KS/-7W.

■ Detailed drawing of the terminal box

■ Assembly drawing (-e/-KS type)

● Output: 1.1kW (50/60Hz) or less

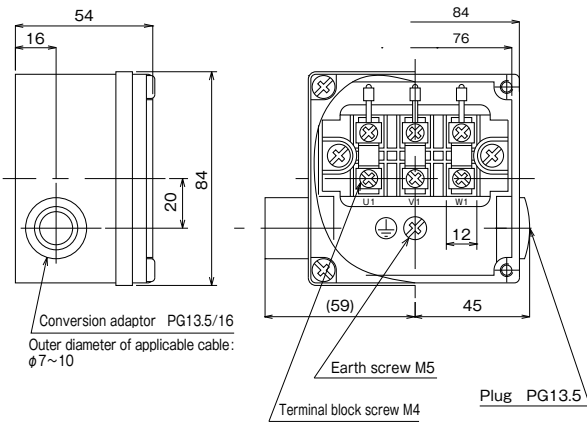

● Output: 1.2kW (50Hz), 1.5kW (60Hz) or more

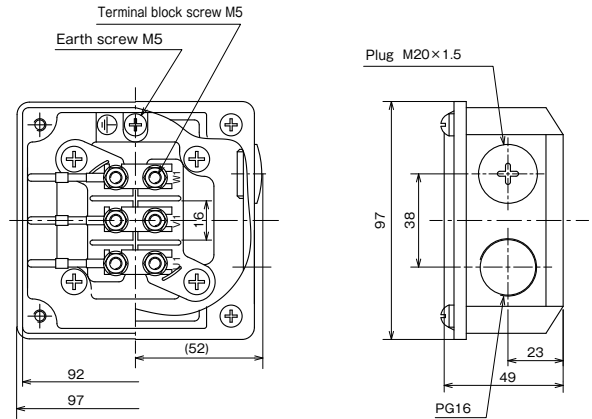

■ Connection diagram

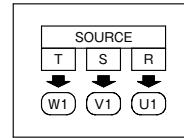
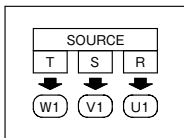

■ Assembly drawing -e (50Hz 380V)

● Output: 1.1kW or less

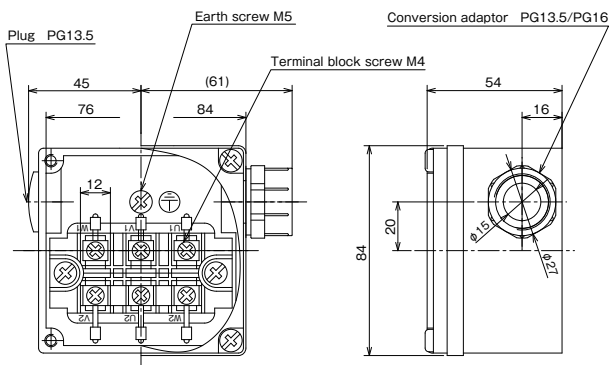

● 1.2kW or more

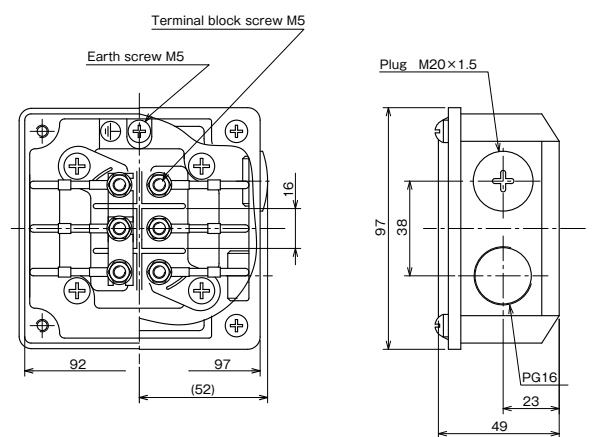

■ Connectin diagram

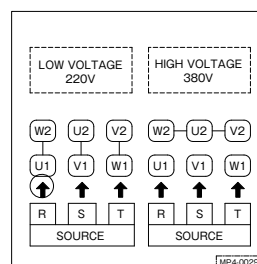
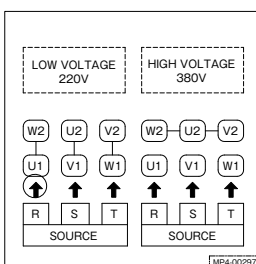

Assembly drawing (-7W type)

●Output: 1.1kW or less

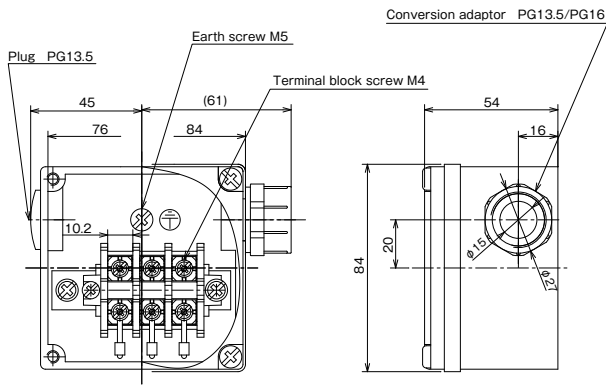

●1.5kW or more

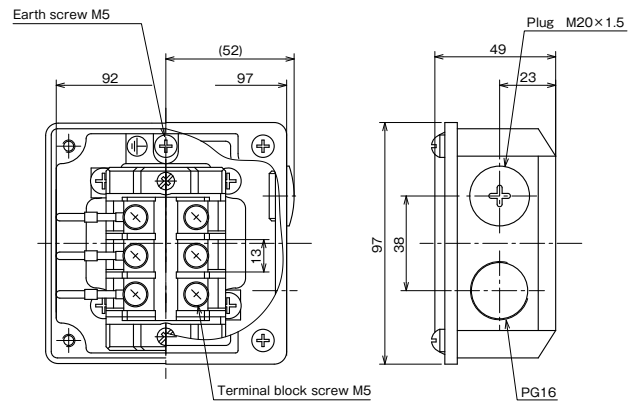

Connection diagram

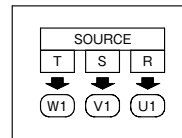
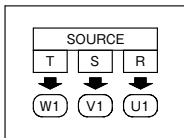

Sectional drawing

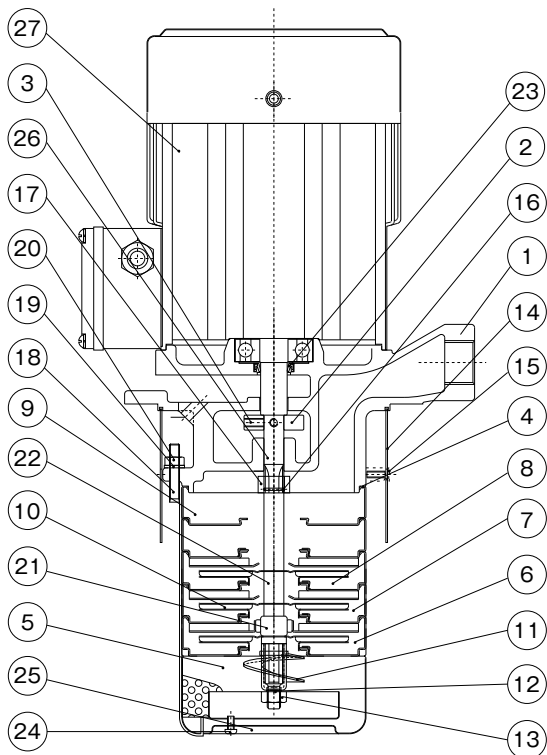

No.	Part name	Material
1	Discharge casing	FC200
2	Oil thrower	SUS304
3	Set screw	SCM435
4	Gasket	—
5	Suction casing	SUS304
6	Intermediate casing (First stage)	SUS304
7	Bearing casing	SUS304+SiC
8	Intermediate casing	SUS304
9	Intermediate casing (Last stage)	SUS304
10	Impeller	SUS304
11	Screw	SUS304
12	Washer	SUS304
13	Impeller nut	SUS304
14	Outer sleeve	SUS304
15	Cross recessed flat head screw	SUS304
16	Shaft ring	SUS316
17	Shaft pushing	SUS304
18	Bolt for fastening plate	SUS304
19	Washer	SUS304
20	Hexagon nut	SUS304
21	Bearing	SiC
22	Sleeve	SUS304
23	Oil seal	NBR
24	Cross recessed pan head screw	SUS304
25	Strainer	SUS304
26	Main shaft (motor side+pump side)	S45C+SUS431
27	Motor	—

Note 1) The materials in the table above are equivalents.

Note 2) Structure and other details are subject to change without notice.

Features

- ① Strong and tough enough to resist dirty coolants.
- ② Non-seal structure (mechanical seal-less) is adopted for excellent durability.
- ③ Two immersion depth options are available.
A suction pipe can be installed to allow flexible adjustment of the operating water level.
- ④ Can be used for high viscosity coolants.
- ⑤ The high-efficiency model (code "H") achieves one of the highest pump efficiencies in the market, delivering a maximum pump efficiency of over 70%.
- ⑥ The lineup including the models complying with global standards by supporting efficiency and other regulations.
Japan : Top Runner efficiency
Europe : IE3 efficiency, CE marking (EU Directive)
RoHS Directive (2011/65/EU) , 10 substances restricted
China : GB3 (GB18613-2020 GB3)



Please note that the paint color, etc. of the actual unit may partially differ from the photo.

Description of types

LPWE 40 4 A - 3.0 -e

① ② ③ ④ ⑤ ⑥ ⑦ ⑧

- ① Model
- ② Bore diameter
- ③ Number of impellers
- ④ Liquid viscosity A : for low viscosity liquid, B : for high viscosity liquid
- ⑤ ID Code None : Standard, L : Long leg type, H : High efficiency type
- ⑥ Frequency None : 50/60Hz, 5 : 50Hz
- ⑦ Output
- ⑧ Motor efficiency -e : Top Runner efficiency (equivalent to IE3)

Standard specifications/Special specifications - : Not available

Liquid used	Property of liquid	Water soluble coolant, liquids of similar viscosity to water containing additives (anti-rust agents) and the like*1	
	Liquid temperature	0 to 60°C (No frozen liquid)	
Installation location	Indoor, ambient temperature : 0 to 40°C, RH85% or less (no condensation), Height above sea level : 1000m or less		
	Place not exposed to direct sunlight, Place in an area free of corrosive or explosive gas or vapor		
Allowable kinematic viscosity	A (for low viscosity liquid) : 32mm ² /s or less		
	B (for high viscosity liquid) : 150mm ² /s or less		
Specifications	Standard specifications	Special specifications	
Structure	Shaft seal	Non-seal (mechanical seal less) -	
Material	Casing (Suction/Discharge/Middle)	FC200 High efficiency type: combination of FC200, FCD450, and SCS13 -	
	Impeller	FCD450 High efficiency type: SCS13 -	
	Main shaft	S45C -	
Motor	Type	Totally enclosed fan-cooled indoor type -	
	Protection method	IP44 -	
	Power source*2	3-phase 50/60Hz 200/200-220V 3-phase 50Hz 210V/220V/380V/400V/415V 3-phase 60Hz 400V/440V	
	Thermal class	B -	
	Rating	Continuous (S1) -	
	Number of poles	2P -	
	Terminal box position	90° to the left with discharge port facing the front Every 90 degrees with discharge port facing the front	
	Terminal box cable entry direction	Bottom With the terminal box facing the front, cable entry on the right side With the terminal box facing the front, cable entry on the left side	
Terminal box cable entry adaptor	- G3/4 conduit mounting		
Painting	Paint color	Munsell N1.5 -	

*Please note that in case of special specifications, the assembly drawing, etc., may differ from the standard drawing.

*1 The pump is not suitable for use with water. If the liquid contains high-hardness foreign matter or large amount of foreign matter (including cutting chips), please contact TERAL INC.

*2 GB3 : 3-phase 50Hz 200V, 50Hz 380V

Global standards

Type	Standards/Regulations	Output
		0.75kW-3.0kW
LPWE-e	Top Runner efficiency (IE3 equivalent)	●
	CE Marking EU energy efficiency	●
	GB3(GB18613-2020)	●*1

*1 GB certification label is attached as exclusive for GB standard. ● : Compliant

Special accessories

Companion flange	With O-ring and bolts
Eye bolt	2 pcs
Strainer for extension pipe *1	

*1 Extension pipe is not included. Available pipe diameter : 50A

Selection chart

Standard/High efficiency type

● For low viscosity liquid (Values at kinematic viscosity $1\text{mm}^2/\text{s}$, specific gravity 1)

50Hz

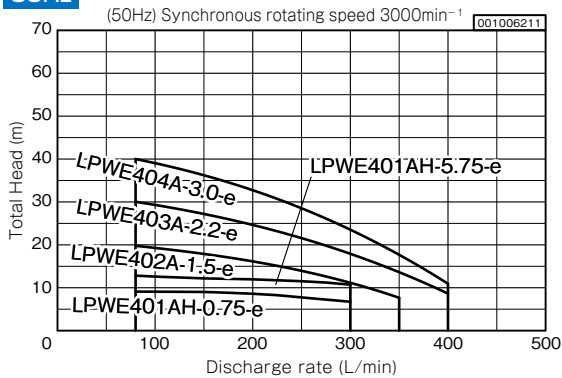

60Hz

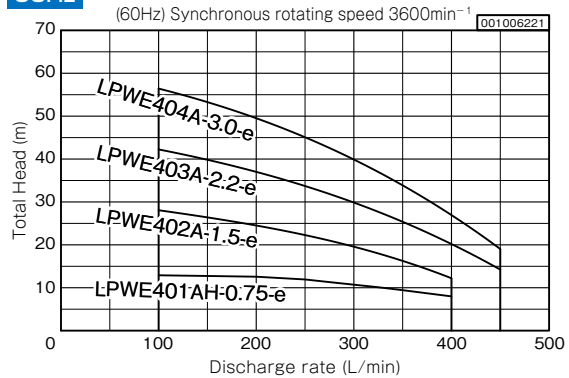

● For high-viscosity liquid (Value at $150\text{mm}^2/\text{s}$ kinematic viscosity, specific gravity 1)

50Hz

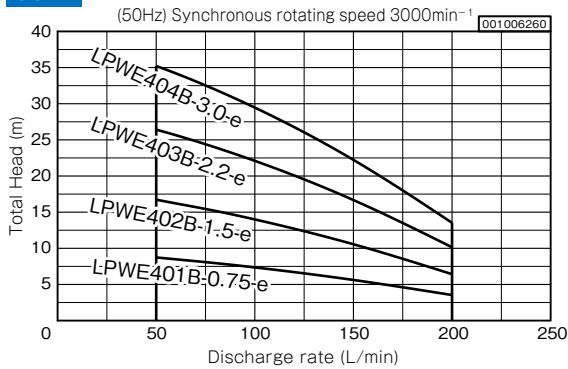

60Hz

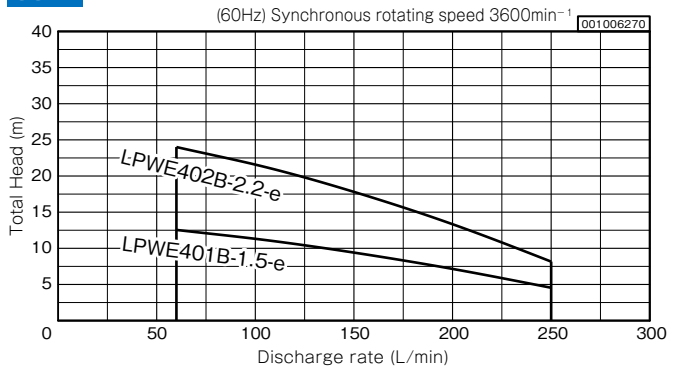

Long leg type

● For low viscosity liquid (Values at kinematic viscosity $1\text{mm}^2/\text{s}$, specific gravity 1)

50Hz

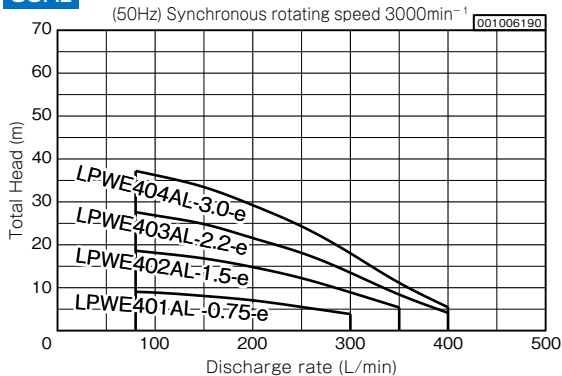

60Hz

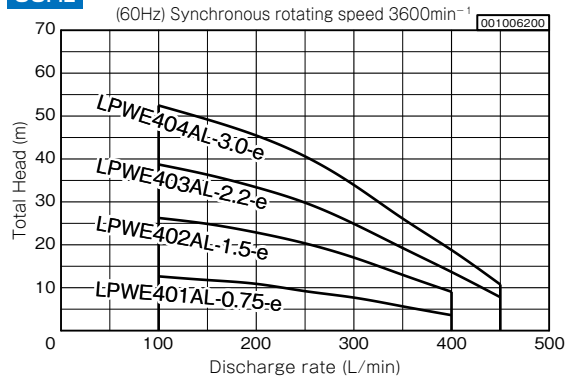

● For high viscosity liquid (Values at kinematic viscosity $150\text{mm}^2/\text{s}$, specific gravity 1)

50Hz

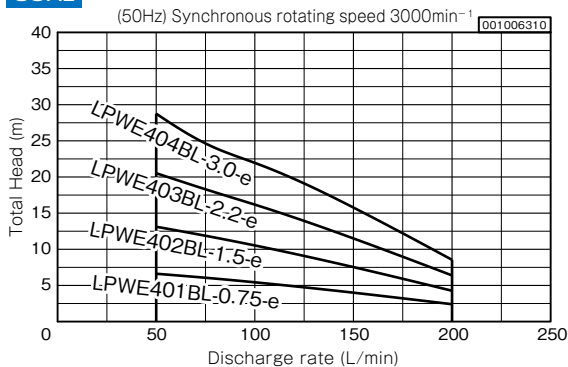

60Hz

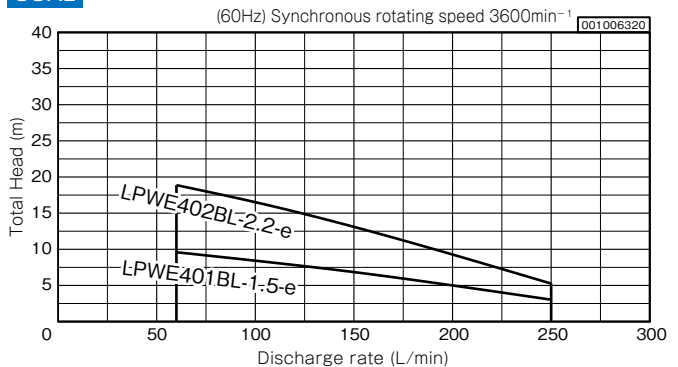

Specification table

● LPWE-e

Frequency Hz	Bore diameter mm	Rated output kW	Type	Rated voltage V	Rated current A	Start current A	Flow rate L/min	Total head m
50	40	0.75	LPWE401AH-0.75-e	200	3.5	28	80-300	8.6-6.2
		0.75	LPWE401AH-5.75-e	200	4.0	28		12.3-10.2
		1.5	LPWE402A-1.5-e	200	6.1	64	80-350	19.8-7.6
		2.2	LPWE403A-2.2-e	200	8.6	86	80-400	30.0-8.6
		3.0	LPWE404A-3.0-e	200	12.6	164		40.0-10.9
		0.75	LPWE401B-0.75-e	200	3.5	28		50-200
		1.5	LPWE402B-1.5-e	200	6.2	64	16.7-6.4	
		2.2	LPWE403B-2.2-e	200	9.0	86	26.4-10.1	
		3.0	LPWE404B-3.0-e	200	12.5	164	35.2-13.5	
		0.75	LPWE401AL-0.75-e	200	3.6	28	80-300	8.9-3.9
		1.5	LPWE402AL-1.5-e	200	6.1	64	80-350	18.6-5.4
		2.2	LPWE403AL-2.2-e	200	8.6	86	80-400	27.6-4.1
		3.0	LPWE404AL-3.0-e	200	12.6	164		37.2-5.4
		0.75	LPWE401BL-0.75-e	200	3.5	28		50-200
		1.5	LPWE402BL-1.5-e	200	6.2	64	13.1-4.3	
		2.2	LPWE403BL-2.2-e	200	9.0	86	20.5-6.4	
3.0	LPWE404BL-3.0-e	200	12.5	164	28.8-8.5			
0.75	LPWE401AH-0.75-e	200/220	3.6/3.4	27/29	100-400	12.4-7.5		
1.5	LPWE402A-1.5-e	200/220	7.5	61/68		28.1-12.2		
2.2	LPWE403A-2.2-e	200/220	10.0	79/87		100-450	42.2-14.2	
3.0	LPWE404A-3.0-e	200/220	14.0	129/144	56.4-19.0			
60	40	1.5	LPWE401B-1.5-e	200/220	6.0	61/68	50-250	12.5-4.5
		2.2	LPWE402B-2.2-e	200/220	8.4	79/87		24.0-8.2
		0.75	LPWE401AL-0.75-e	200/220	4.0	27/29	100-400	12.6-3.6
		1.5	LPWE402AL-1.5-e	200/220	7.5	61/68		26.3-9.0
		2.2	LPWE403AL-2.2-e	200/220	10.0	79/87		100-450
		3.0	LPWE404AL-3.0-e	200/220	14.0	129/144	52.5-10.7	
		1.5	LPWE401BL-1.5-e	200/220	6.0	61/68	50-250	9.6-3.0
		2.2	LPWE402BL-2.2-e	200/220	8.4	79/87		18.9-5.3

Note 1) The rated current shown in the table above (as listed on the name plate) represent the recommended current setting values for protection device.

Note 2) The start current in the table above is a representative value. The actual current may be up to approximately 20% higher than the listed value.

● LPWE-e (50Hz 380V)

Frequency Hz	Bore diameter mm	Rated output kW	Type	Rated voltage V	Rated current A	Start current A	Flow rate L/min	Total head m
50	40	0.75	LPWE401AH-0.75-e	380	1.5	13	80-300	8.6-6.2
		0.75	LPWE401AH-5.75-e	380	1.8	13		12.3-10.2
		1.5	LPWE402A-1.5-e	380	3.1	33	80-350	19.8-7.6
		2.2	LPWE403A-2.2-e	380	5.0	43	80-400	30.0-8.6
		3.0	LPWE404A-3.0-e	380	6.0	73		40.0-10.9
		0.75	LPWE401B-0.75-e	380	2.0	13		50-200
		1.5	LPWE402B-1.5-e	380	3.1	33	16.7-6.4	
		2.2	LPWE403B-2.2-e	380	5.0	43	26.4-10.1	
		3.0	LPWE404B-3.0-e	380	6.2	73	35.2-13.5	
		0.75	LPWE401AL-0.75-e	380	2.0	13	80-300	8.9-3.9
		1.5	LPWE402AL-1.5-e	380	3.1	33	80-350	18.6-5.4
		2.2	LPWE403AL-2.2-e	380	5.0	43	80-400	27.6-4.1
		3.0	LPWE404AL-3.0-e	380	6.0	73		37.2-5.4
		0.75	LPWE401BL-0.75-e	380	2.0	13		50-200
		1.5	LPWE402BL-1.5-e	380	3.1	33	13.1-4.3	
		2.2	LPWE403BL-2.2-e	380	5.0	43	20.5-6.4	
3.0	LPWE404BL-3.0-e	380	6.2	73	28.8-8.5			

Note 1) The rated current shown in the table above (as listed on the name plate) represent the recommended current setting values for protection device.

Note 2) The start current in the table above is a representative value. The actual current may be up to approximately 20% higher than the listed value.

Assembly drawing

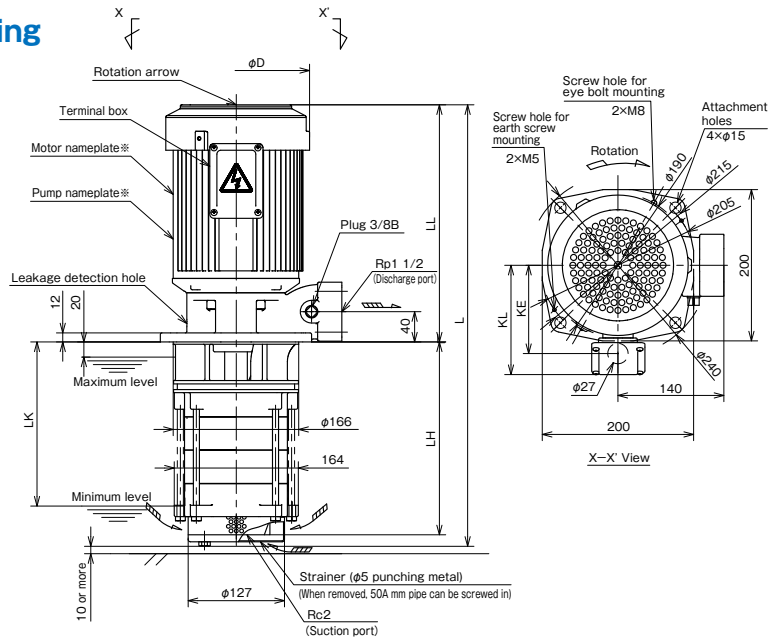

※ The product with GB3 motor has an additional certification nameplate and the nameplate position is different.

Dimensions

(Unit : mm)

Frequency Hz	Type	ϕD	K L	KE	L	LH	LK	L L	Approx. mass kg
50	LPWE401AH-0.75-e	170	139	111	551	255	217	281	33
	LPWE401AH-5.75-e	170	139	111	551	255	217	281	33
	LPWE402A-1.5-e	195	145	117	584	255	217	314	38
	LPWE403A-2.2-e	195	145	117	594	255	217	324	48
	LPWE404A-3.0-e	195	145	117	668	299	261	354	52
	LPWE401B-0.75-e	170	139	111	551	255	217	281	31
	LPWE402B-1.5-e	195	145	117	584	255	217	314	38
	LPWE403B-2.2-e	195	145	117	594	255	217	324	48
	LPWE404B-3.0-e	195	145	117	668	299	261	354	52
	LPWE401AL-0.75-e	170	139	111	683	387	349	281	35
	LPWE402AL-1.5-e	195	145	117	716	387	349	314	42
	LPWE403AL-2.2-e	195	145	117	726	387	349	324	53
	LPWE404AL-3.0-e	195	145	117	756	387	349	354	56
	LPWE401BL-0.75-e	170	139	111	683	387	349	281	35
LPWE402BL-1.5-e	195	145	117	716	387	349	314	42	
LPWE403BL-2.2-e	195	145	117	726	387	349	324	53	
LPWE404BL-3.0-e	195	145	117	756	387	349	354	56	
60	LPWE401AH-0.75-e	170	139	111	551	255	217	281	33
	LPWE402A-1.5-e	195	145	117	584	255	217	314	38
	LPWE403A-2.2-e	195	145	117	594	255	217	324	48
	LPWE404A-3.0-e	195	145	117	668	299	261	354	52
	LPWE401B-1.5-e	195	145	117	584	255	217	314	37
	LPWE402B-2.2-e	195	145	117	594	255	217	324	47
	LPWE401AL-0.75-e	170	139	111	683	387	349	281	35
	LPWE402AL-1.5-e	195	145	117	716	387	349	314	42
	LPWE403AL-2.2-e	195	145	117	726	387	349	324	53
	LPWE404AL-3.0-e	195	145	117	756	387	349	354	56
	LPWE401BL-1.5-e	195	145	117	716	387	349	314	41
	LPWE402BL-2.2-e	195	145	117	726	387	349	324	52

Detailed drawing of the terminal box

Assembly drawing

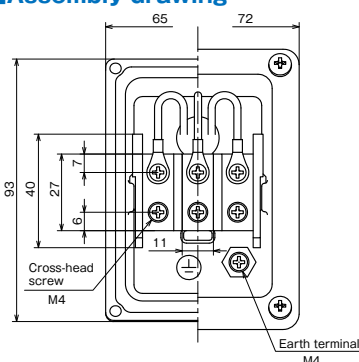

Connection diagram

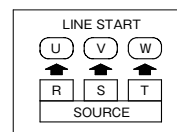

Sectional drawing

High efficiency type

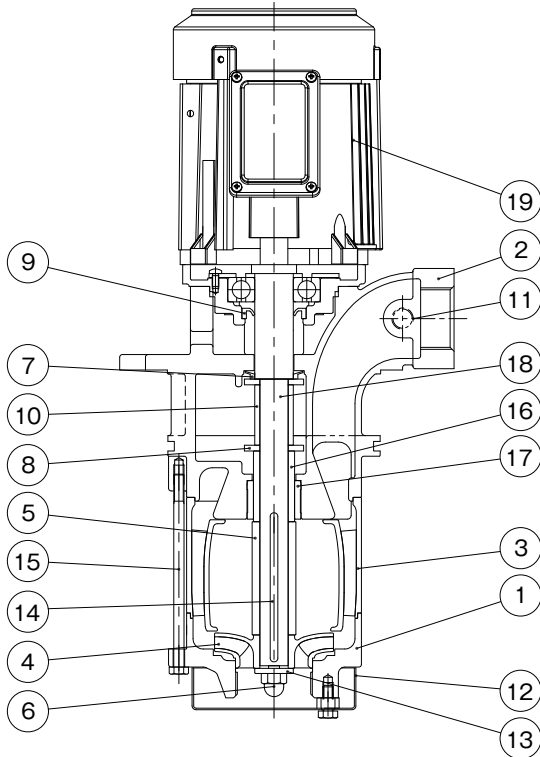

No.	Part name	Qty	Material
1	Suction casing	1	FCD450
2	Discharge casing	1	FC200
3	Intermediate casing	1	SCS13
4	Impeller	1	SCS13
5	Spacer	1	STKM
6	Impeller nut	1	SUS304
7	Deflector	1	NBR
8	Deflector	2	SPHC
9	Oil seal	1	NBR
10	Collar	1	STKM
11	Plug	1	SWCH
12	Strainer	1	SS400
13	Washer	1	SUS304
14	Key	1	S45C
15	Through bolt	4	SS400
16	Shaft sleeve	1	SUS440C
17	Discharge bushing	1	SKD11
18	Motor shaft	1	S45C
19	Motor	1	-

Note 1) The materials in the table above are equivalents.
 Note 2) Structure and other details are subject to change without notice.
 Applicable models : LPWE401AH-0.75-e · LPWE401AH-5.75-e

Standard type

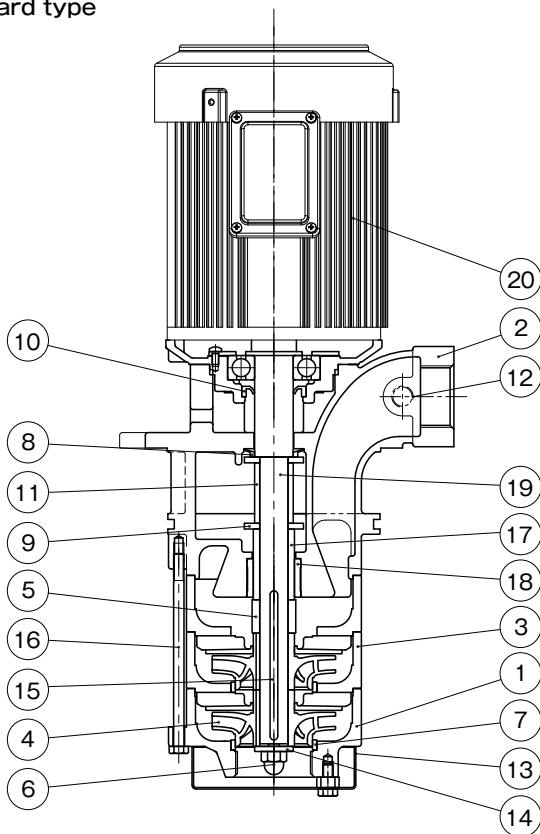

No.	Part name	Qty	Material
1	Suction casing	1	FC200
2	Discharge casing	1	FC200
3	Intermediate casing	2	FC200
4	Impeller	2	FCD450
5	Shaft spacer	1	STKM
6	Impeller nut	1	SUS304
7	Wearing ring	2	SUS304
8	Deflector	1	NBR
9	Deflector	2	SPHC
10	Oil seal	1	NBR
11	Collar	1	STKM
12	Plug	1	SWCH
13	Strainer	1	SS400
14	Washer	1	SUS304
15	Key	1	S45C
16	Through bolt	4	SS400
17	Shaft sleeve	1	SUS440C
18	Discharge bushing	1	SKD11
19	Motor shaft	1	S45C
20	Motor	1	-

Note 1) The materials in the table above are equivalents.
 Note 2) Structure and other details are subject to change without notice.
 Applicable models : LPWE402A(B)-1.5-e · LPWE402B-2.2-e

Long leg type

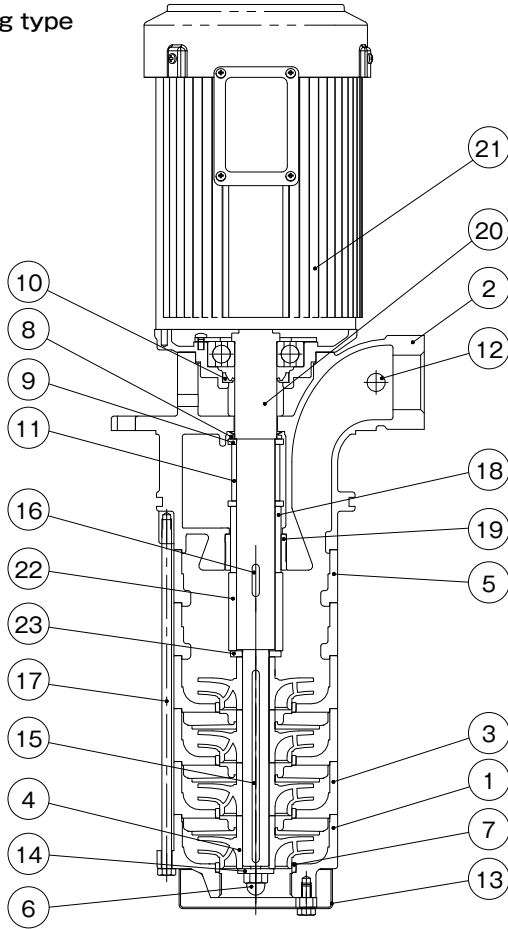

No.	Part name	Qty	Material
1	Suction casing	1	FC200
2	Discharge casing	1	FC200
3	Intermediate casing	3	FC200
4	Impeller	4	FCD450
5	Intermediate spacer	2	FC200
6	Impeller nut	1	SUS304
7	Wearing ring	4	SUS304
8	Deflector	1	NBR
9	Deflector	2	SPHC
10	Oil seal	1	NBR
11	Collar	1	STKM
12	Plug	1	SWCH
13	Strainer	1	SS400
14	Washer	1	SUS304
15	Key	1	S45C
16	Key	1	S45C
17	Through bolt	4	SS400
18	Shaft sleeve	1	SUS440C
19	Discharge bushing	1	SKD11
20	Motor shaft	1	S45C
21	Motor	1	-
22	Shaft spacer	1	STKM
23	Exclusive washer	1	SS400

Note 1) The materials in the table above are equivalents.

Note 2) Structure and other details are subject to change without notice.

Applicable models : LPWE404A(B)L-3.0-e

■ Features

- ① Strong and tough enough to resist dirty coolants.
- ② The impeller made of FCD material and non-seal (mechanical seal-less) structure is adopted for excellent durability.
- ③ Mounting the inlet piping allows you to freely set the operating water level (LPW65-e).
- ④ Can be used for high viscosity coolants (LPW40-7W/LPW65-e).
- ⑤ The lineup including the models complying with global standards by supporting efficiency and other regulations.
 Japan : Top Runner efficiency
 USA : NEMA Premium efficiency (IE3 efficiency), UL standards (safety)



Please note that the paint color, etc. of the actual unit may partially differ from the photo.

■ Description of types

Bore diameter 40mm **LPW 40 1 C - 0.75 -7W**
 ① ② ③ ⑤ ⑦ ⑨

Bore diameter 50/65mm **LPW 65 3 /2 A - 6 5.5 L -e**
 ① ② ③ ④ ⑤ ⑥ ⑦ ⑧ ⑨

- ① Model
- ② Bore diameter
- ③ Number of casings
- ④ Number of impellers
(blank if number is equal to number of casings)
- ⑤ Liquid viscosity
A,C : for low viscosity liquid
D : for high viscosity liquid
- ⑥ Frequency 5:50Hz 6:60Hz
- ⑦ Output
- ⑧ ID code
- ⑨ Motor efficiency
-e : Top Runner efficiency (equivalent to IE3)
-7W : UL approved motor (3.0kW or less is NEMA Premium efficiency)

■ Standard Specification

Bore diameter		40mm	50mm	65mm
Used liquid	Property of liquid	Coolants of the kinematic viscosity equivalent to that of water-soluble coolants or water containing an additive (anticorrosive, etc.) ^{*1}		Water-soluble coolant liquid ^{*1}
	Temperature	0 to 60° C (No frozen liquid)		
	Allowable kinematic viscosity	40C : 32mm ² /s 40D : 150mm ² /s	1mm ² /s	
Installation location		Indoor Ambient temperature: 0 to 40 ° C, RH 85% or below (no condensation), Height above sea level : 1000m or less, Place not exposed to direct sunlight, Place in an area free of corrosive or explosive gas or vapor.		
Material	Casing Suction · Discharge · Intermediate	FC200		
	Impeller	FCD450		
	Shaft	S35C	S45C	
Shaft seal structure		Non-seal (mechanical seal-less)		
Motor	Power source	3-phase 50/60/60Hz 200/200/220V ^{*2*}		
	Type	Totally enclosed fan-cooled indoor type	Totally enclosed fan-cooled outdoor type ^{*4}	
	Protection method	IP54	IP44	IP55
	Thermal class	F		
	Rating	Continuous		
	Number of poles	2P		
Paint color		Munsell N1.5		

^{*1} Avoid using the pump with water. Contact us when using the unit for coolant containing foreign substances with high hardness or a large amount of foreign substances including chips.
^{*2} NEMA Premium efficiency (IE3), UL Standards (safety) : 60Hz 208/230/460V
^{*3} LPW65-e: 3-phase 50/60/60Hz 200/200/230V
^{*4} The pump cannot be used outdoors.

■ Special specification

Shaft seal structure change (wear resistance improvement)

■ Table of Consumable Parts

Output (kW)	Specification	Bearing		Oil seal	
		Load side	Unload side	Load side	Unload side
1.5	-e	6306ZZC3	6303ZZC3	VC30508	—
5.5		6309ZZC3	6306ZZC3	VC45628	VC30528
7.5		6309ZZC3	6306ZZC3		
0.75	-7W	6306ZZC3	6203ZZCM	SC30457	HM25385
1.5		6306ZZC3	6205ZZCM		
2.2		6306ZZC3	6205ZZCM		
3.0		6307ZZC3	6205ZZCM		

Bore diameter (mm)	O-ring (for companion flange)	O-ring (for water seal plate)
50	S67	—
65	—	S56

Selection chart

● LPW40-7W

● For low viscosity liquid

(Values at kinematic viscosity 1mm²/s, specific gravity 1)

60Hz

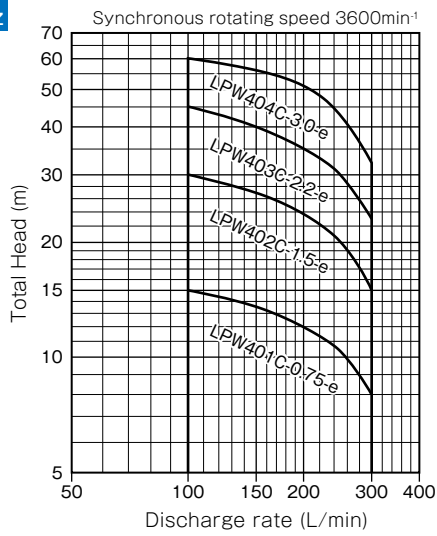

● For high-viscosity liquid

(Value at 150 mm²/s kinematic viscosity, specific gravity 1)

60Hz

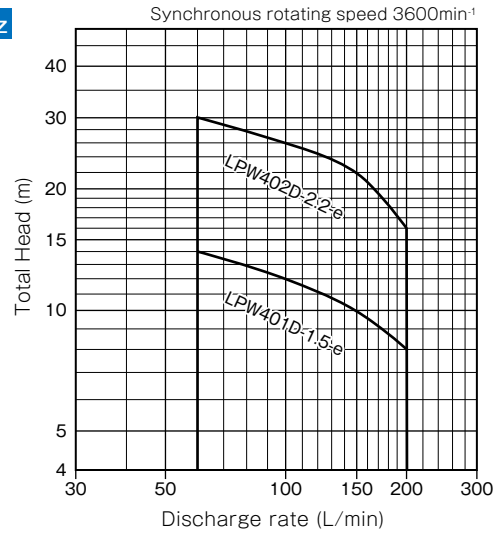

Specification table

● LPW40-7W

Bore diameter (mm)	Frequency (Hz)	Used liquid	Output (kW)	Type	Rated voltage (V)	Rated current (A)	Starting current (A)	Discharge rate (L/min)	Total head (m)
40	60	For low viscosity liquid	0.75	LPW401C-0.75-7W	208/230/460	4.0/3.9/2.0	33.9/38.0/19.0	100-300	15-8
			1.5	LPW402C-1.5-7W	208/230/460	6.5/6.0/3.1	47.3/52.0/26.0		30-15
			2.2	LPW403C-2.2-7W	208/230/460	8.9/8.5/4.3	74.8/83.0/41.5		45-23
			3.0	LPW404C-3.0-7W	208/230/460	12.5/11.8/6.0	119.4/130/65.0		64-32
		For high-viscosity liquid	1.5	LPW401D-1.5-7W	208/230/460	6.5/6.0/3.1	47.3/52.0/26.0	60-200	14-8
			2.2	LPW402D-2.2-7W	208/230/460	8.9/8.5/4.3	74.8/83.0/41.5		30-16

Note 1) Discharge rate and total head are the values obtained in the tests with a liquid viscosity of 1mm²/s (same as fresh water at normal temperature).

Note 2) The pump's rated current (current value listed on the pump nameplate) is the recommended current setting for protection device.

■ Selection chart

● LPW50

(Values at kinematic viscosity 1mm²/s, specific gravity 1)

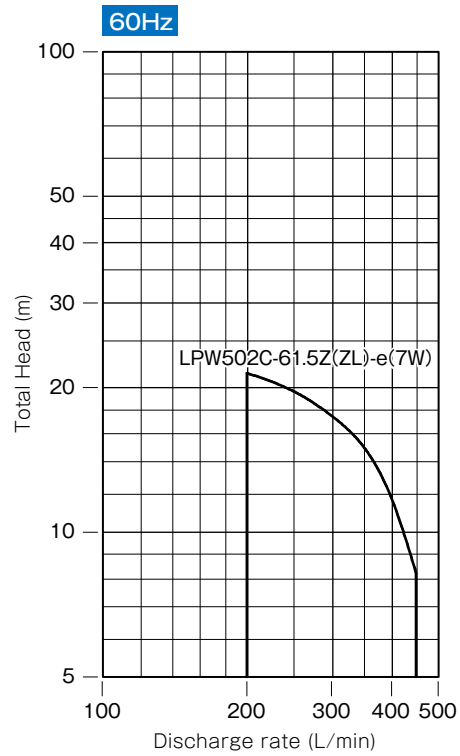
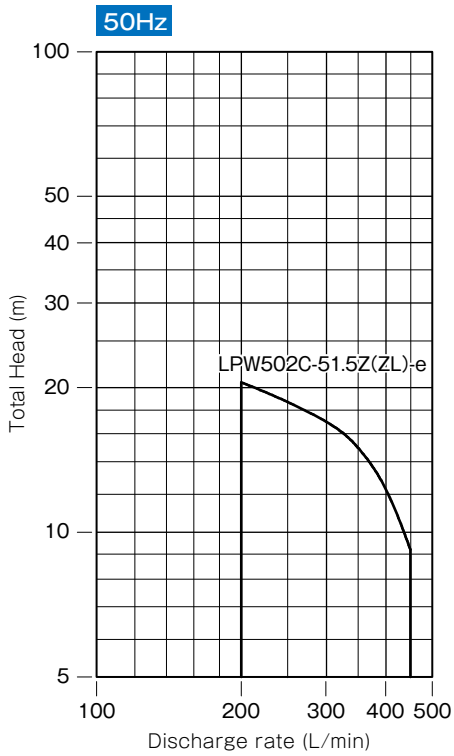

■ Specification table

● LPW50

Bore diameter (mm)	Frequency (Hz)	Output (kW)	Type	Rated voltage (V)	Rated current (A)	Starting current (A)	Discharge rate (L/min)	Total head (m)
50	50	1.5	LPW502C-51.5Z-e	200	6.6	66.0	200-450	20.5-9
			LPW502C-51.5ZL-e					
	60		LPW502C-61.5Z-e	200/220	6.5/6.0	64.0/70.0		
			LPW502C-61.5ZL-e					
			LPW502C-61.5ZL-7W	208/230/460	6.5/6.0/3.1	47.3/52.0/26.0		

Note) The pump's rated current (current value listed on the pump nameplate) is the recommended current setting for protection device.

Selection chart

● LPW65

● For low viscosity liquid (Values at kinematic viscosity 1mm²/s, specific gravity 1)

50Hz

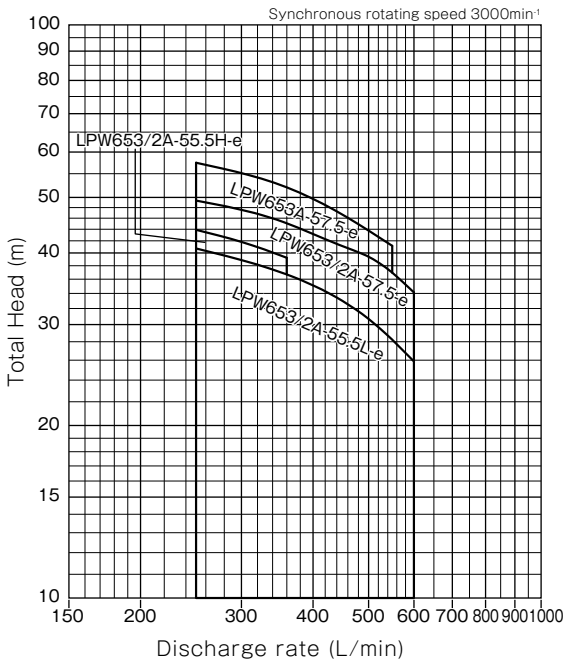

60Hz

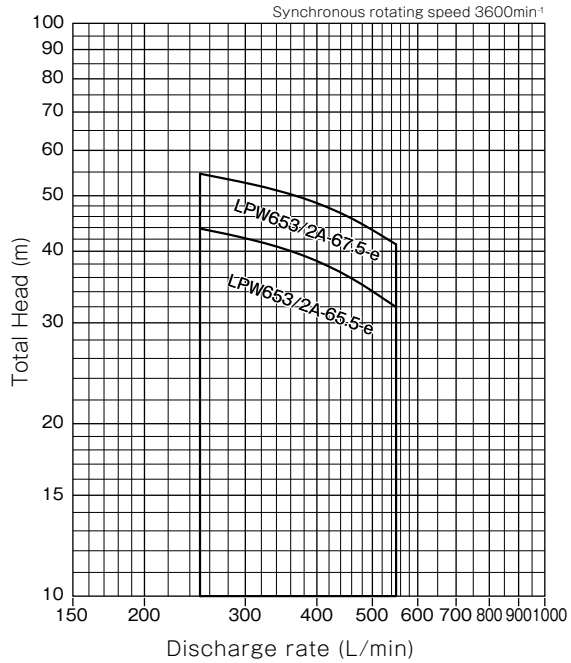

Specification table

● LPW65

Bore diameter (mm)	Frequency (Hz)	Output (kW)	Type	Rated voltage (V)	Rated current (A)	Starting current (A)	Discharge rate (L/min)	Total head (m)
65	50	5.5	LPW653/2A-55.5L-e	200	20.3	204	250-600	40.7-25.9
		5.5	LPW653/2A-55.5H-e		20.3	204	250-360	43.9-39.2
		7.5	LPW653/2A-57.5-e		27.2	288	250-600	49.4-34.1
		7.5	LPW653A-57.5-e		27.2	288	250-550	57.5-41.2
	60	5.5	LPW653/2A-65.5-e	200/230	19.8/17.8	178/206	250-550	43.8-32.0
		7.5	LPW653/2A-67.5-e		26.5/23.7	254/295	250-550	54.6-41.1

Note) The pump's rated current (current value listed on the pump nameplate) is the recommended current setting for protection device.

Assembly drawing

●LPW40-7W 0.75kW

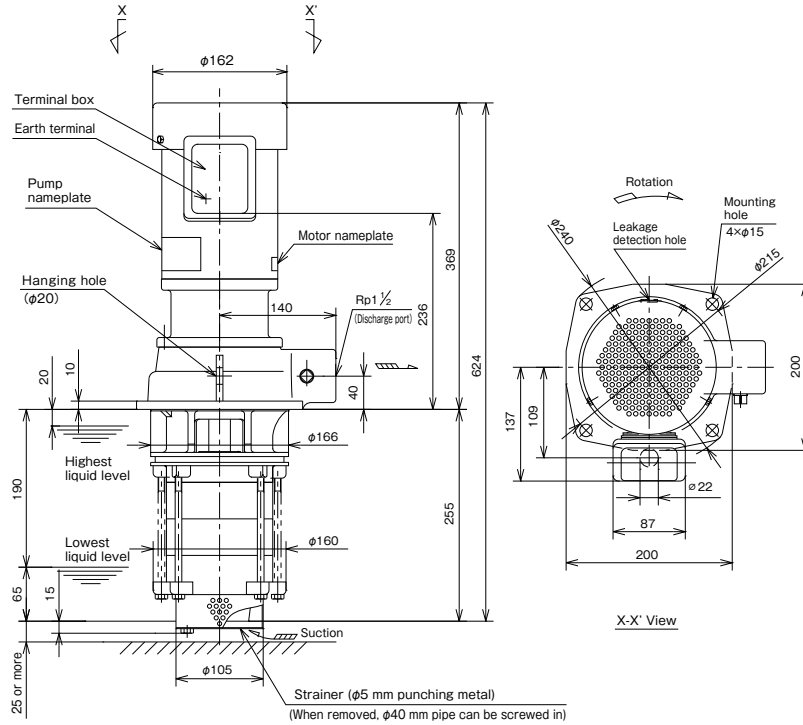

Approx.mass 35Kg

●LPW40-7W 1.5kW or more

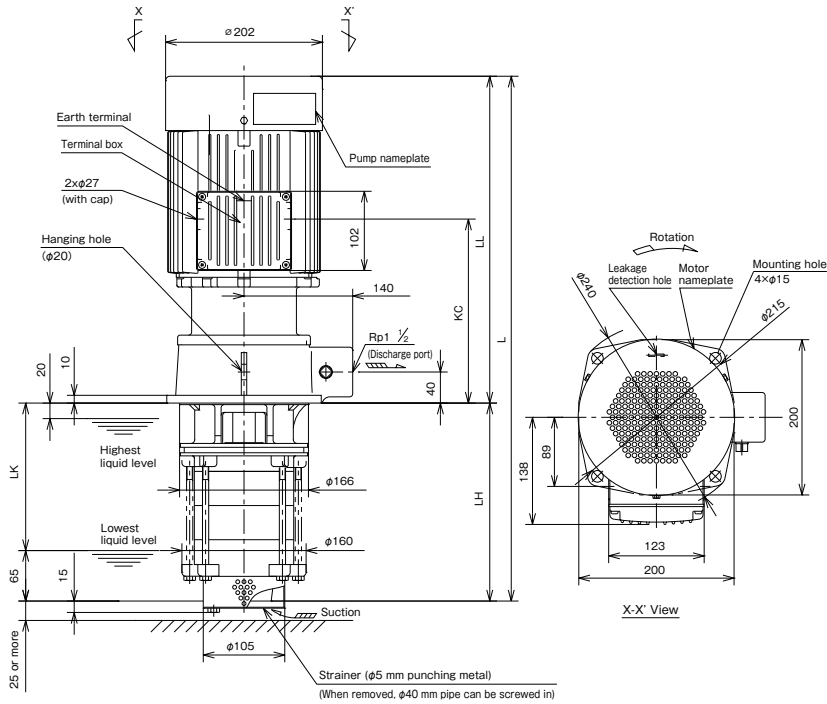

Dimensions

●LPW40-7W 1.5kW or more

(Unit : mm)

Bore diameter	Frequency (Hz)	Used liquid	Type	KC	L	LH	LK	LL	Approx. mass(kg)
40	60	For low viscosity	LPW402C-1.5-7W	237	676	255	190	421	45
			LPW403C-2.2-7W	237	676	255	190	421	52
			LPW404C-3.0-7W	240	743	299	234	444	59
		For high viscosity	LPW401D-1.5-7W	237	676	255	190	421	44
			LPW402D-2.2-7W	237	676	255	190	421	51

Assembly drawing

●LPW50-e

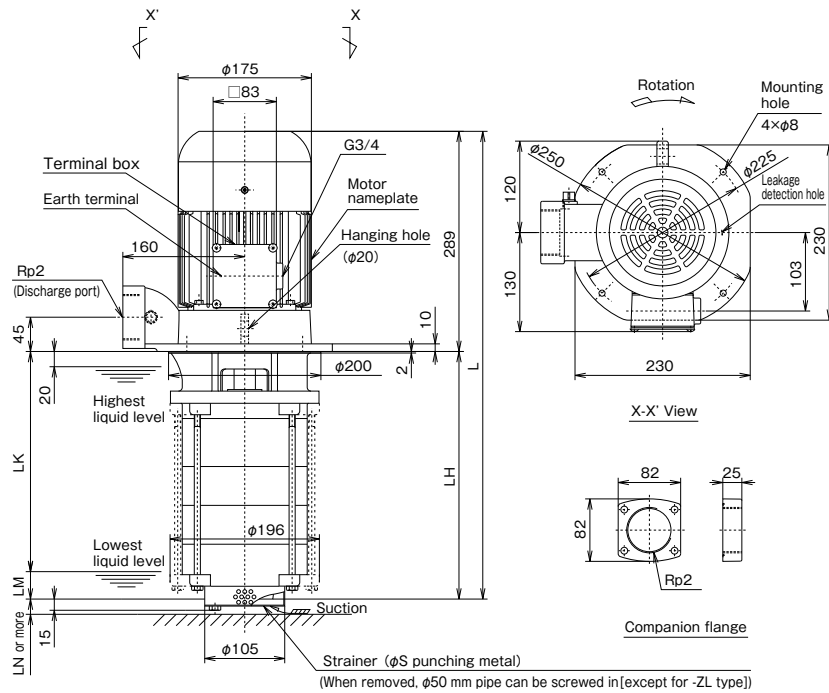

Dimensions

●LPW50-e

(Unit : mm)

Bore diameter	Frequency (Hz)	Type	LH	LK	LM	LN	L	S	Approx. mass(kg)
50	50	LPW502C-51.5Z-e	219	168	51	25	508	6	40
	60	LPW502C-61.5Z-e							
	50	LPW502C-51.5ZL-e	325	289	36	20	614	6	45
	60	LPW502C-61.5ZL-e							

●LPW502C-61.5ZL-7W

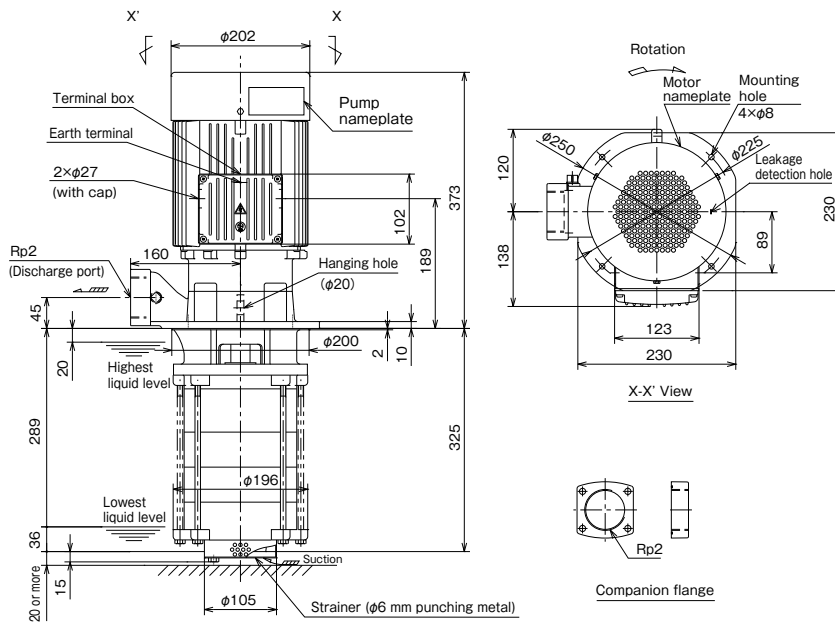

Approx.mass 55Kg

Assembly drawing

●LPW65-e

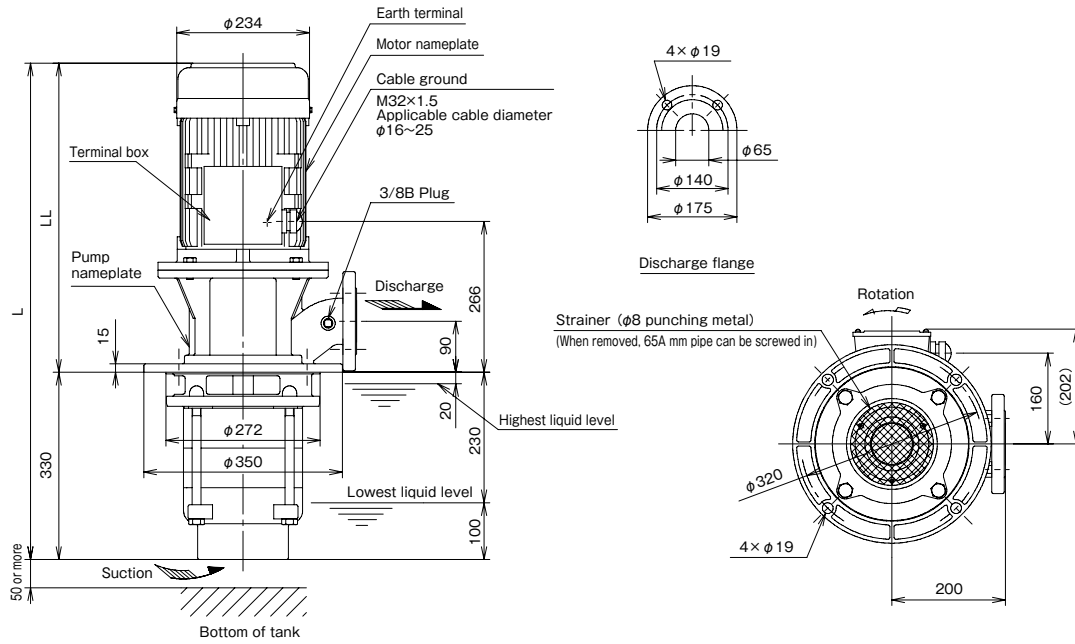

Dimensions

●LPW65-e

(Unit : mm)

Bore diameter	Frequency (Hz)	Type	LL	L	Approx. mass(kg)
65	50	LPW653/2A-55.5L-e	545	875	97
		LPW653/2A-55.5H-e			97
		LPW653/2A-57.5-e	585	915	100
		LPW653A-57.5-e			102
	60	LPW653/2A-65.5-e	545	875	97
		LPW653/2A-67.5-e	585	915	100

Detailed drawing of the terminal box

● LPW50-e

■ Assembly drawing

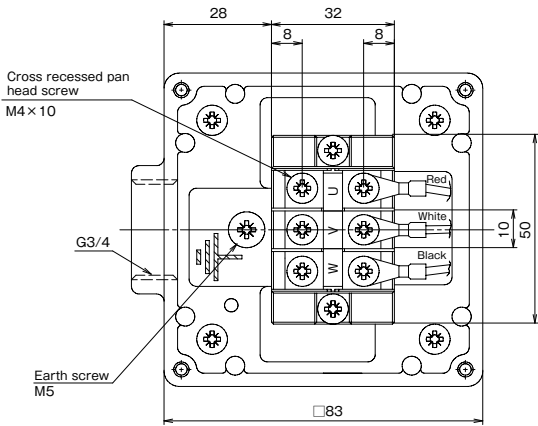

● LPW65-e

■ Assembly drawing

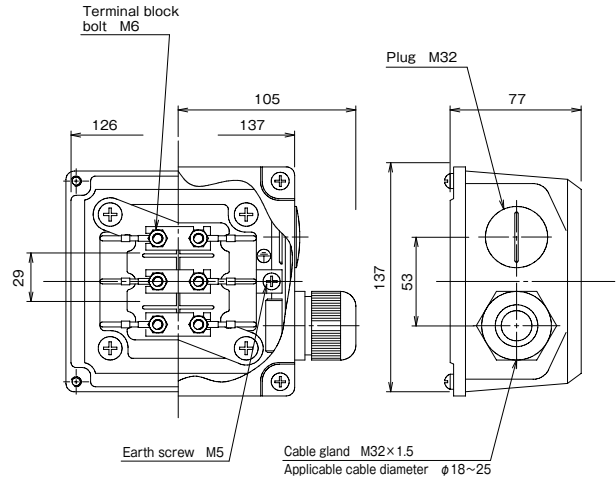

● LPW50-e

■ Connection diagram

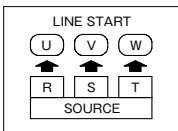

● LPW65-e

■ Connection diagram

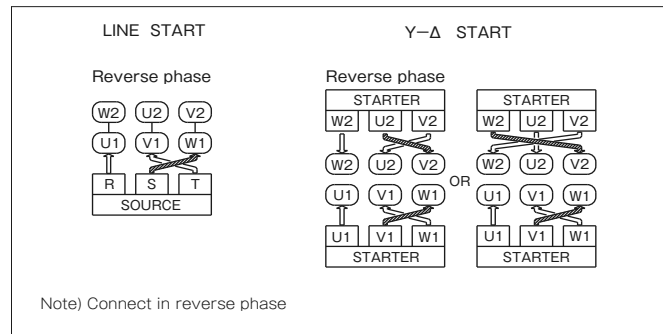

● LPW-7W 0.75kW

■ Assembly drawing

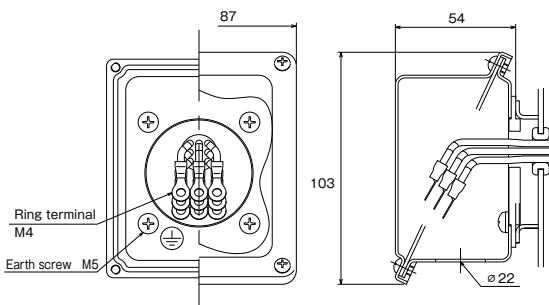

● LPW-7W 1.5kW or more

■ Assembly drawing

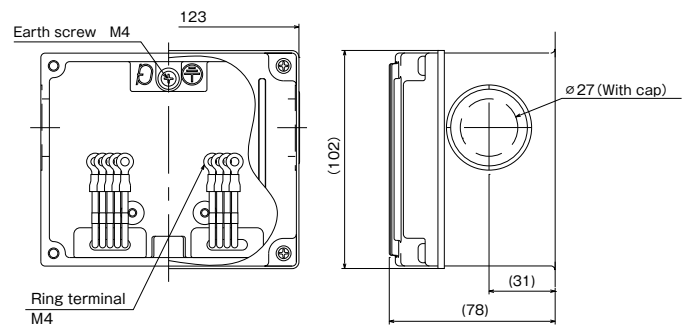

● LPW-7W Full output

■ Connection diagram

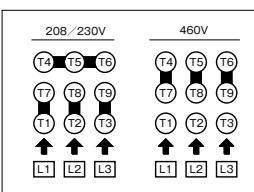

Sectional drawing

●LPW40-7W

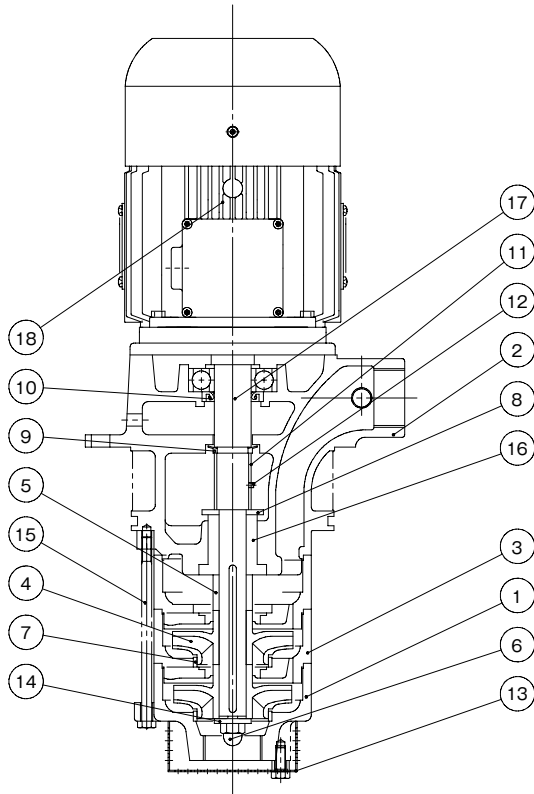

No.	Part name	Qty	Material
1	Suction casing	1	FC200
2	Discharge casing	1	FC200
3	Intermediate casing	2	FC200
4	Impeller	2	FCD450
5	Shaft spacer	1	STKM
6	Impeller nut	1	SUS304
7	Wearing ring	2	SUS304
8	Deflector	1	SS400
9	Deflector	1	NBR
10	Oil seal	1	NBR
11	Collar	1	STKM
12	Hexagon socket set screw	1	SCM435
13	Strainer	1	SPCC
14	Washer	1	SUS420J1
15	Through bolt	4	SS400
16	Shaft sleeve	1	FCD450
17	Main shaft	1	S35C
18	Motor	1	

Note 1) The materials in the table above are equivalents.
Note 2) Structure and other details are subject to change without notice.

●LPW50-ZL

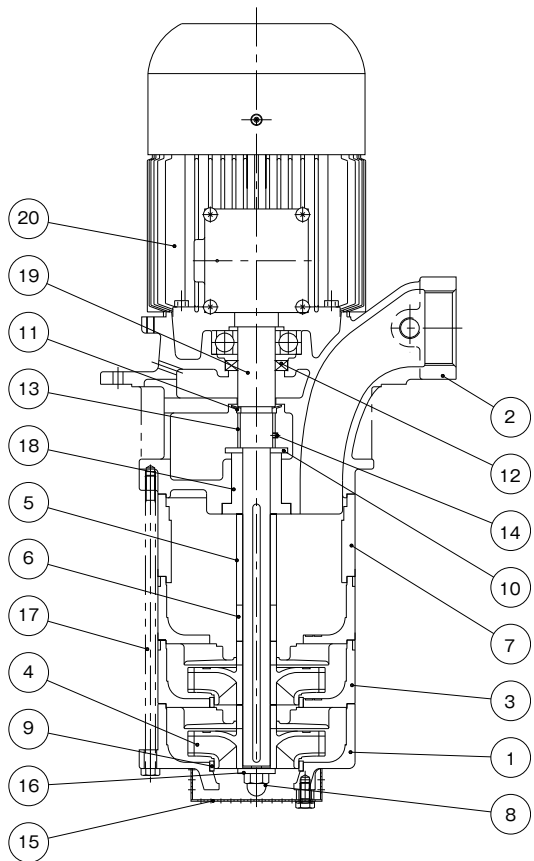

No.	Part name	Qty	Material
1	Suction casing	1	FC200
2	Discharge casing	1	FC200
3	Intermediate casing	2	FC200
4	Impeller	2	FCD450
5	Shaft spacer	1	STKM
6	Shaft spacer	1	STKM
7	Intermediate spacer	1	STKM
8	Impeller nut	1	SUS304
9	Wearing ring	2	SUS304
10	Deflector	1	SS400
11	Deflector	1	NBR
12	Oil seal	1	NBR
13	Collar	1	STKM
14	Hexagon socket set screw	1	SCM435
15	Strainer	1	SS400
16	Washer	1	SUS420J1
17	Through bolt	4	SS400
18	Shaft sleeve	1	FCD450
19	Main shaft	1	S35C
20	Motor	1	

Note 1) The materials in the table above are equivalents.
Note 2) Structure and other details are subject to change without notice.

Sectional drawing

●LPW65

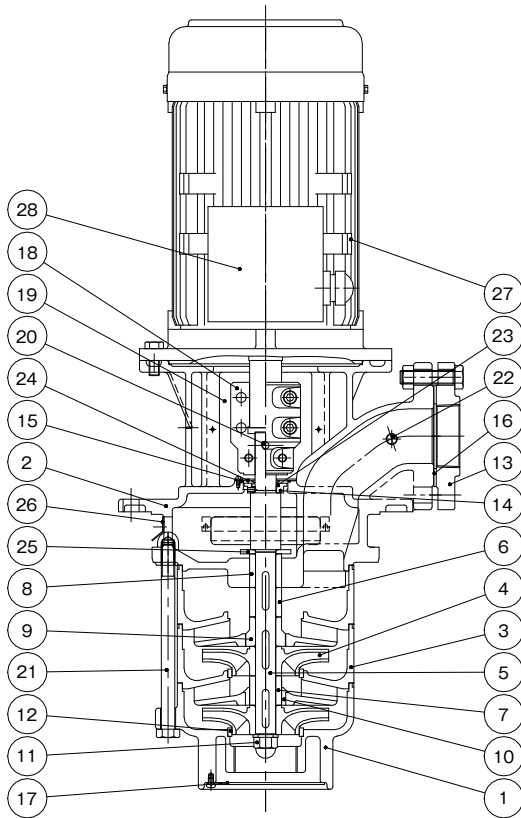

No.	Part name	Qty	Material
1	Suction casing	1	FC200
2	Discharge casing	1	FC200
3	Intermediate casing	2	FC200
4	Impeller	2	FCD450
5	Main shaft	1	S45C
6	Shaft sleeve A	1	SUS304
7	Shaft sleeve B	1	SiC
8	Shaft sleeve C	1	SUS304
9	Shaft sleeve D	1	SUS304
10	Intermediate bushing	1	SiC
11	Impeller nut	1	SUS304
12	Wearing ring	2	SUS304
13	Companion flange	1	FC200
14	Deflector	1	C3604B
15	O-ring	1	NBR
16	Sheet packing	1	NBR
17	Strainer	1	SPCC
18	Coupling	1	FC200
19	Coupling cover	2	SUS304
20	Hexagon socket set screw	1	SCM435
21	Through bolt	4	SS400
22	Plug	1	SS400
23	V-ring	1	FKM
24	Coolant sealing plate	1	SUS304
25	Deflector	1	SUS304
26	Cover	3	SUS304
27	Motor	1	
28	Terminal box	1	ADC12

Note 1) The materials in the table above are equivalents.
 Note 2) Structure and other details are subject to change without notice.
 Applicable models: 50Hz LPW653/2A-55.5L-e, LPW653/2A-55.5H-, LPW653/2A-57.5-e
 60Hz LPW653/2A-65.5-e, LPW653/2A-67.5-e

Features

- ① Energy-saving pump equipped with a Top Runner (equivalent to IE3) motor.
- ② As the immersion length is as short as 330mm in all models, tank depths can be reduced.
- ③ Serial operation allows generating up to 3.92 MPa.*
- ④ The fluid level during operation can be adjusted as preferred by connecting the intake piping.
- ⑤ Non-seal (mechanical seal-less) structure is adopted for excellent durability.
- ⑥ Stainless steel and special resin with high reliability are used in the pump's main unit.
- ⑦ The mounting dimension is compatible with conventional models.

*The value is for reference only.



Please note that the paint color, etc. of the actual unit may partially differ from the photo.

Description of types

LKW 20 09 -6 3.0 D -e

① ② ③ ④ ⑤ ⑥ ⑦

- | | |
|-----------------------------|---|
| ① Model | ⑥ Operating method |
| ② Bore diameter | None : single operation |
| ③ Number of impellers | D : series operation |
| ④ Frequency 5: 50Hz 6: 60Hz | ⑦ Motor efficiency Top Runner (equivalent to IE3) |
| ⑤ Output | |

Standard Specification

Used liquid	Property of liquid	Water-soluble coolant liquid
	Temperature	0 to 60° C (No frozen liquid)
	Allowable kinematic viscosity	1mm ² /s
Installation location		Indoor Ambient temperature: 0 to 40° C, RH 85% or below (no condensation), Height above sea level : 1000m or less, Place not exposed to direct sunlight, Place in an area free of corrosive or explosive gas or vapor.
Material	Suction cover · Discharge casing	FC200
	Intermediate casing	ARLS* +SUS304
	Impeller	ARLS*
	Shaft	S35C
Shaft seal structure		Non-seal (mechanical seal-less)
Motor	Power source	3-phase 50/60/60 Hz, 200/200/220 V
	Type	Totally enclosed fan-cooled indoor type
	Protection method	IP44
	Thermal class	F
	Rating	Continuous
	Number of poles	2P
Paint color		Munsell N1.5

* Special polyamide resin reinforced with glass fiber, etc.

Table of Consumable Parts

Output (kW)	Bearing		Oil seal	O-ring (For intermediate casing and spacer)
	Load side	Unload side		
2.2	6306ZZC3	6303ZZC3	VC30456	G135
3.0	6308ZZC3	6205ZZC3	VC40586	
4.0	6308ZZC3	6205ZZC3	VC40586	

■ Selection chart

(Values at kinematic viscosity 1mm²/s, specific gravity 1)

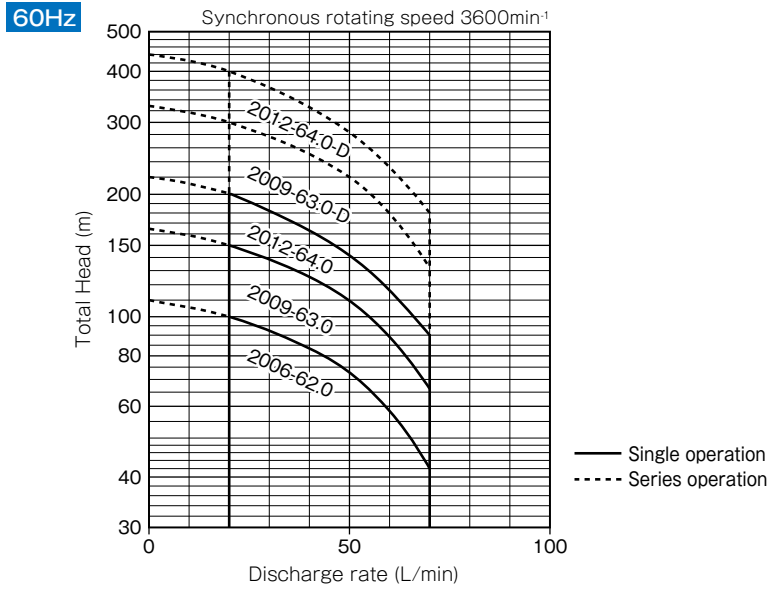
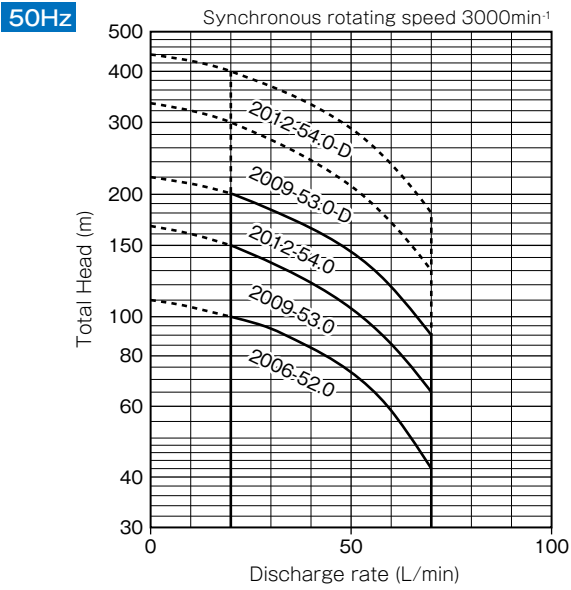

■ Specification table

Bore diameter (mm)	Frequency (Hz)	Type	Rated voltage (V)	Output (kW)	Rated current (A)	Starting current (A)	Discharge rate (L/min)	Total head (m)
20	50	LKW2006-52.0-e	200	2.2	9.3	84	20-70	100-42
		LKW2009-53.0-e		3.0	14.8	180	20-70	150-65
		LKW2012-54.0-e		4.0	16.0	179	20-70	200-90
		LKW2009-53.0-D-e		3.0	14.8	180	20-70	300-130
		LKW2012-54.0-D-e		4.0	16.0	179	20-70	400-180
	60	LKW2006-62.0-e	200/220	2.2	8.4/7.9	73/80	20-70	100-43
		LKW2009-63.0-e		3.0	12.0/12.1	152/167	20-70	150-67
		LKW2012-64.0-e		4.0	15.0/14.0	152/173	20-70	200-90
		LKW2009-63.0-D-e		3.0	12.0/12.1	152/167	20-70	300-134
		LKW2012-64.0-D-e		4.0	15.0/14.0	152/173	20-70	400-180

Notes 1) The pump's rated current (current value listed on the pump nameplate) is the recommended current setting for protection device.
Notes 2) The rated current and the starting current value in the table above are the values per unit.

Assembly drawing

Single operation

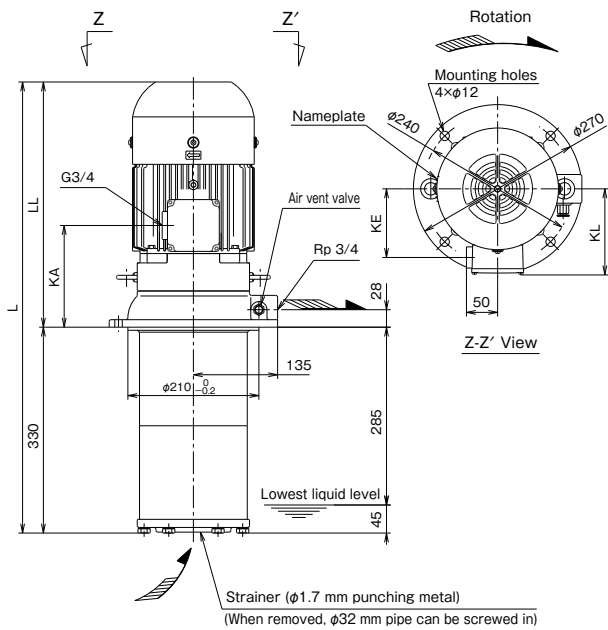

Dimensions

Single operation

(Unit : mm)

Bore diameter	Frequency (Hz)	Type	L	LL	KA	KE	KL	Approx. mass(kg)
20	50	LKW2006-52.0-e	693	363	158	100	128	47
		LKW2009-53.0-e	723	393	163	110	138	55
		LKW2012-54.0-e	736	406	176	110	138	68
	60	LKW2006-62.0-e	693	363	158	100	128	47
		LKW2009-63.0-e	723	393	163	110	138	55
		LKW2012-64.0-e	736	406	176	110	138	68

Series operation

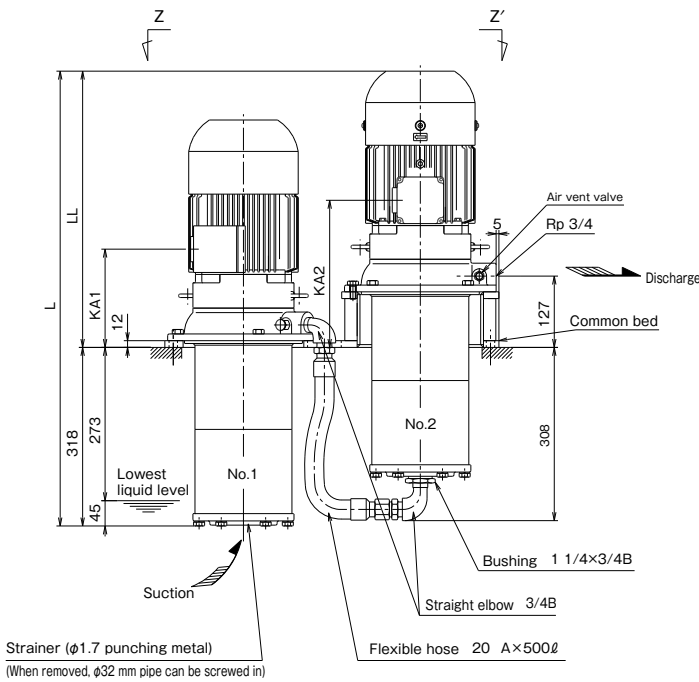

Series operation

(Unit : mm)

Bore diameter	Frequency (Hz)	Type	KA1	KA2	LL	L	Approx. mass(kg)
20	50	LKW2009-53.0-D-e	175	188	492	810	128
		LKW2012-54.0-D-e	262	275	505	823	152
	60	LKW2009-63.0-D-e	175	188	492	810	128
		LKW2012-64.0-D-e	262	275	505	823	152

In the case of series operation, we ship the pumps and the accompanying components in separate packages. Please assemble them at your site.

Detailed drawing of the terminal box

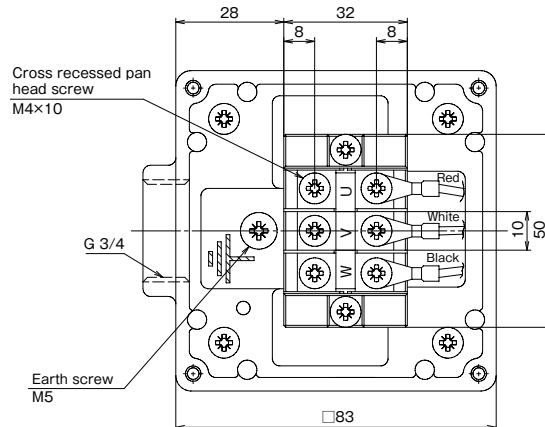
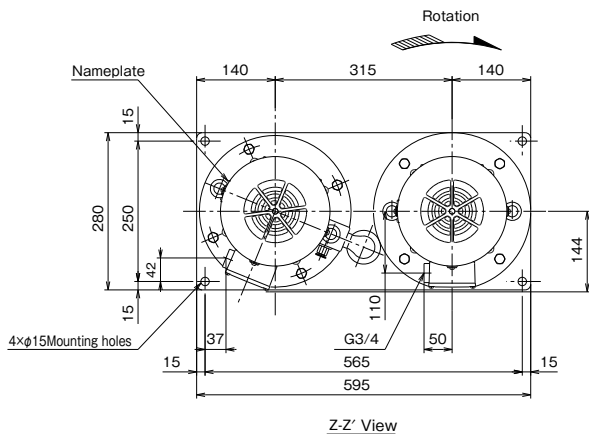

Sectional drawing

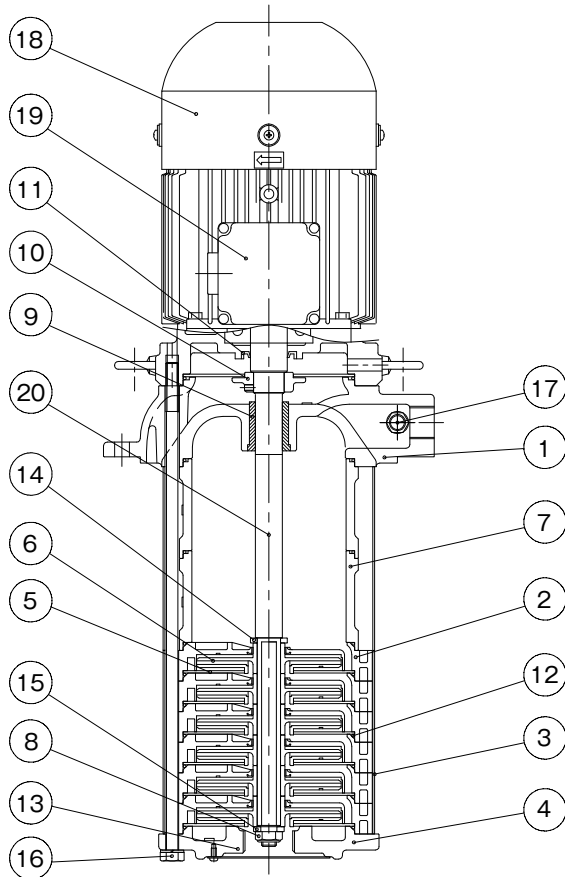

n: Number of stages

No.	Part name	Qty	Material
1	Discharge casing	1	FC200
2	Intermediate casing	n	ARLS ^{※1} + (SUS304)
3	Outer casing	2	SUS304
4	Suction cover	1	FC200
5	Casing cover	n +1	SUS304
6	Impeller	n	ARLS
7	Intermediate spacer	※2	FC200
8	Impeller nut	1	SUS304
9	Discharge bushing	1	SUS420J2
10	Deflector	1	FC200
11	Oil seal	1	NBR
12	O-ring	※3	NBR
13	Strainer	1	SUS304
14	Supporter ring	1	SUS403
15	Washer	1	SUS403
16	Through bolt	6	SS400
17	Air vent valve	1	SUS304
18	Motor	1	ADC
19	Terminal box	1	ADC (※4)
20	Main shaft	1	S35C

※1 Special polyamide resin reinforced with glass fiber, etc.

※2 2.2kW: 2, 3.0kW: 1, 4.0kW: 0

※3 2.2kW: 10, 3.0kW: 12, 4.0kW: 14

※4 Terminal box cover is SECE.

Note 1) The materials in the table above are equivalents.

Note 2) Structure and other details are subject to change without notice.

■ Features

- ① Non-seal (mechanical seal-less) structure is adopted.
- ② Energy-saving pump with a Top Runner (equivalent to IE3) motor.
- ③ Stainless steel is used in the pump's main liquid contact part.
- ④ Measures against air suction into the pump are taken when the fluid level lowers.
- ⑤ The lineup that includes both VKB-H type (pressure type) and VKB-Q type (flow type) broadens the scope of choices of heads and flow rates.
- ⑥ The lineup including the models complying with global standards by supporting efficiency and other regulations.
 Japan : Top Runner efficiency
 Europe : IE3 efficiency, CE marking (EU Directive)
 RoHS Directive (2011/65/EU) , 10 substances restricted
 China : GB3 (GB18613-2020)

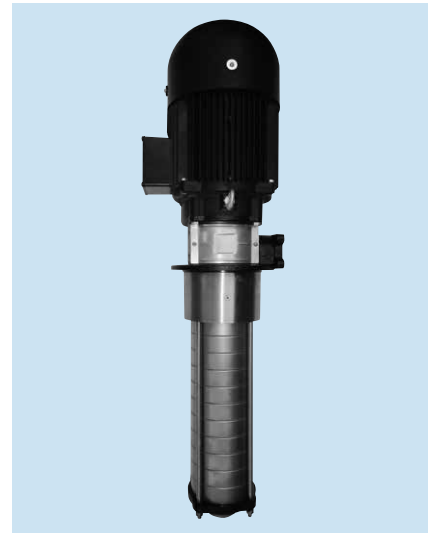

Please note that the paint color, etc. of the actual unit may partially differ from the photo.

■ Description of types

VKB 19 26 2 A H -e

- ① Model
- ② Number of impellers
- ③ Number of stages
- ④ Series number
- ⑤ Frequency A: 50/60Hz
F: 50Hz
- ⑥ Characteristics H: Pressure type
Q: Flow type
- ⑦ Motor efficiency Top Runner efficiency equivalent to IE3

■ Global standards

Type	Standards/Regulations	Output
VKB-e	Top Runner efficiency (IE3 equivalent)	●
	CE Marking EU energy efficiency	●
	GB3(GB18613-2020)	● ^{*1}

*1 GB certification label is attached as exclusive for GB standard. ● : Compliant

■ Standard Specification

Used liquid	Property of liquid	Grinding liquid, cutting liquid, etc., after secondary treatment *1		
	Temperature	-20 to 90° C (No frozen liquid)		
	Allowable kinematic viscosity	Model type	At 50 Hz	At 60 Hz
		VKB07□□2AH-e,VKB04□□2AQ-e VKB06□□2AQ-e,VKB12□□2AQ-e	75mm ² /s	37.5mm ² /s
VKB □□□□2F □ -e (50 Hz exclusive unit)		1mm ² /s	—	
	Models other than the above	75mm ² /s	75mm ² /s	
Installation location		Indoor Ambient temperature: -20 to 40 ° C, RH 85% or below (no condensation), Height above sea level : 1000m or less, Place not exposed to direct sunlight, Place in an area free of corrosive or explosive gas or vapor.		
Material	Pump leg	FC200		
	Casing· Outer casing	SUS304		
	Suction chamber	FC150		
	Impeller	SUS304		
	Main shaft (motor side + pump side)	S35C+SUS316		
Shaft seal structure		Non-seal (mechanical seal-less)		
Motor	Type	Totally enclosed fan-cooled indoor type		
	Protection method	IP54		
	Power source	A: 3-phase 50/60/60Hz 200/200/220V F: 3-phase 50Hz 200V		
	Thermal class	F		
	Number of poles	2P		
	Standard	IEC60034-1 CE Marking		
Paint color	Pump	Munsell N1		
	Motor	Black		

*1 Take note that special liquid such as water, printing liquid or acid liquid cannot be used. Contact us for other special liquid (ceramic, etc.).

■ Table of Consumable Parts

Type	Bearings		Oil seal			O-ring (Companion flange) Material: FKM		
	Load side	Unload side	Load side (Pump part)	Load side (Bearing part)	Unload side			
VKB05□□2FH-e ~ VKB07□□2FH-e	6305ZZC3	6203ZZC3	IS12257	DS17355	VC24406	G50		
VKB04□□2FQ-e								
VKB05□□2AH-e ~ VKB09□□2AH-e	6307ZZC3	6303ZZC3						
VKB08□□2FH-e ~ VKB19□□2FH-e								
VKB04□□2AQ-e ~ VKB06□□2AQ-e								
VKB05□□2FQ-e ~ VKB10□□2FQ-e	6309ZZC3	6205ZZC3					VC25455	VC24406
VKB10□□2AH-e ~ VKB19□□2AH-e								
VKB20□□2FH-e ~ VKB26□□2FH-e								
VKB07□□2AQ-e ~ VKB12□□2AQ-e								
VKB13□□2FQ-e ~ VKB22□□2FQ-e								

■ Special specification

Motor modifications	Voltage change, change of terminal box position, change of terminal box direction
Change of structure	Stainless steel suction chamber *

* The pump is not 100% made of stainless steel. Pump legs and companion flanges are made of cast iron. "-SU" is added to the model type as a suffix.

Selection chart

●VKB-H

(Values at kinematic viscosity 1mm²/s, specific gravity 1)

Synchronous rotating speed 50Hz : 3000min⁻¹
60Hz : 3600min⁻¹

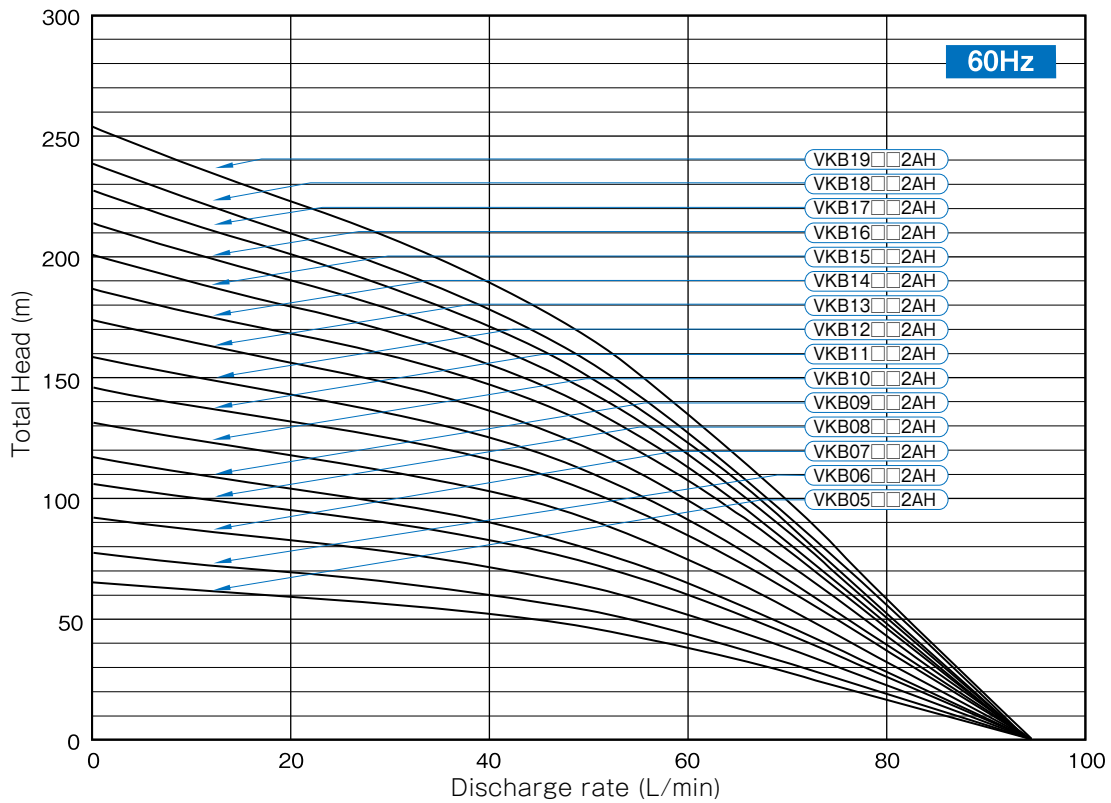
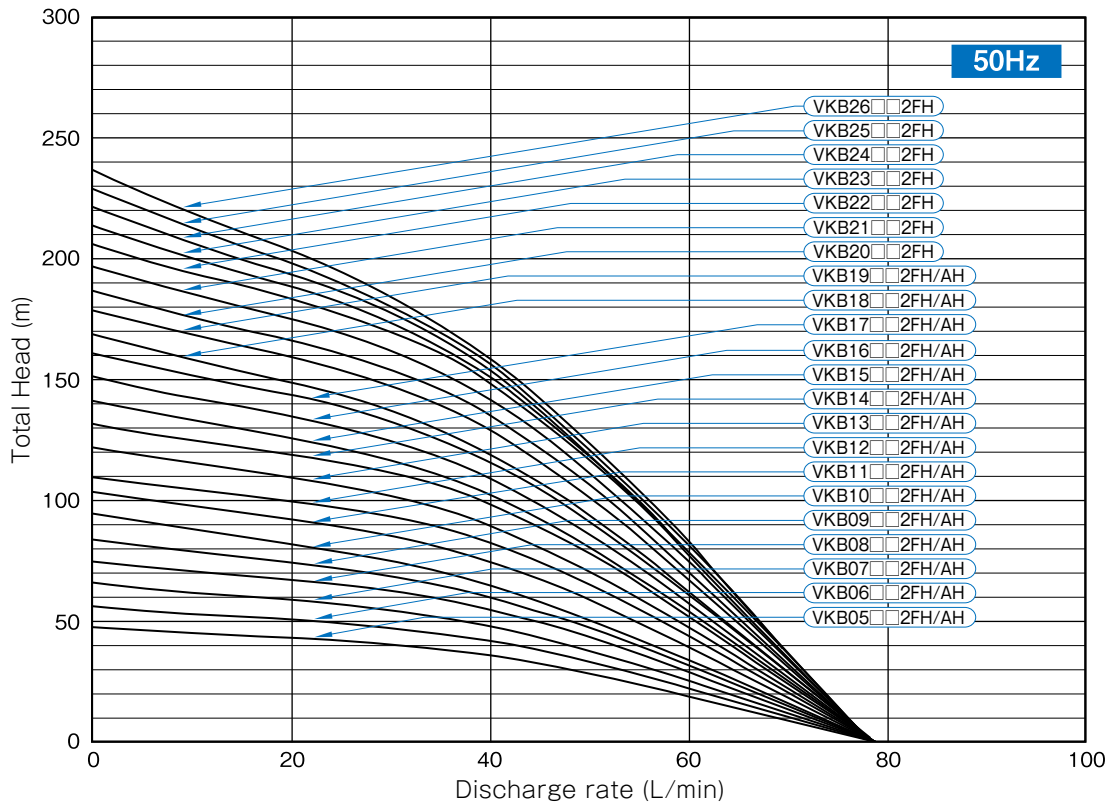

Note 1) The above characteristic curves reflect the full impeller condition of the units. The total head may be decreased depending on the flow rate if empty casings are involved because of pressure loss at the empty casings.

Note 2) Take note that discharge rate varies considerably depending on the type and kinematic viscosity of liquid. Above selection chart may not be used depending on the kinematic viscosity and specific gravity of the liquid.

Selection chart

●VKB-Q

(Values at kinematic viscosity 1mm²/s, specific gravity 1)

Synchronous rotating speed 50Hz : 3000min⁻¹
60Hz : 3600min⁻¹

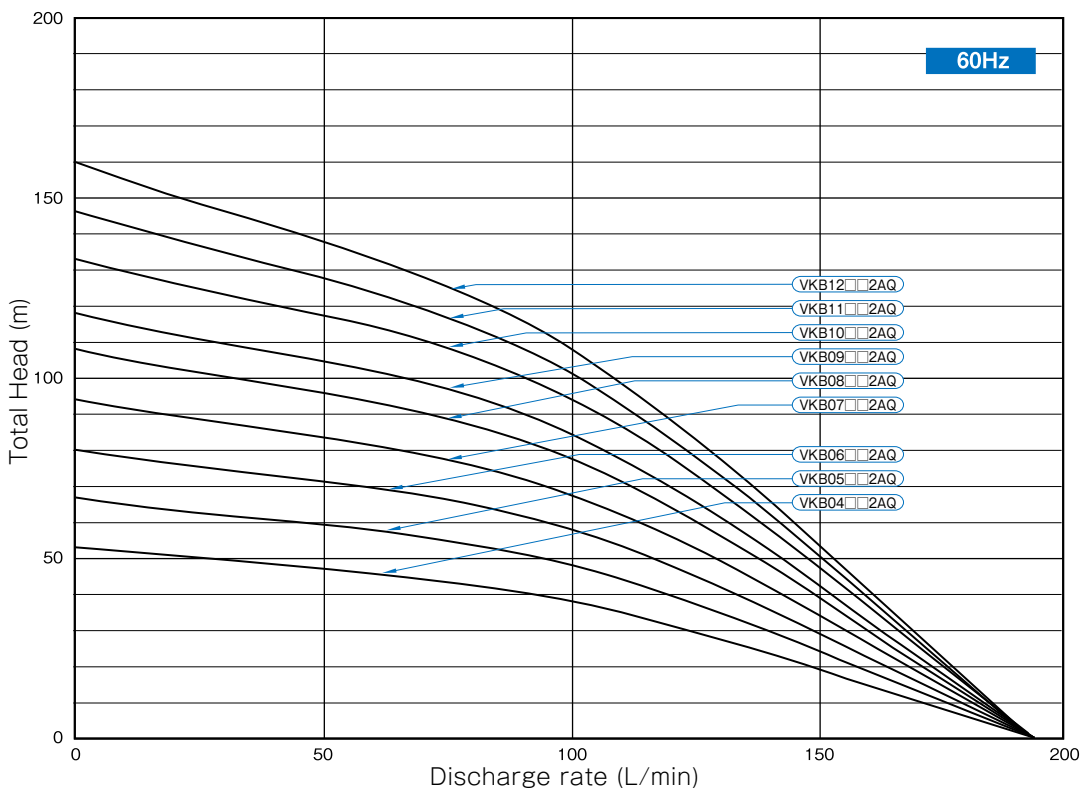
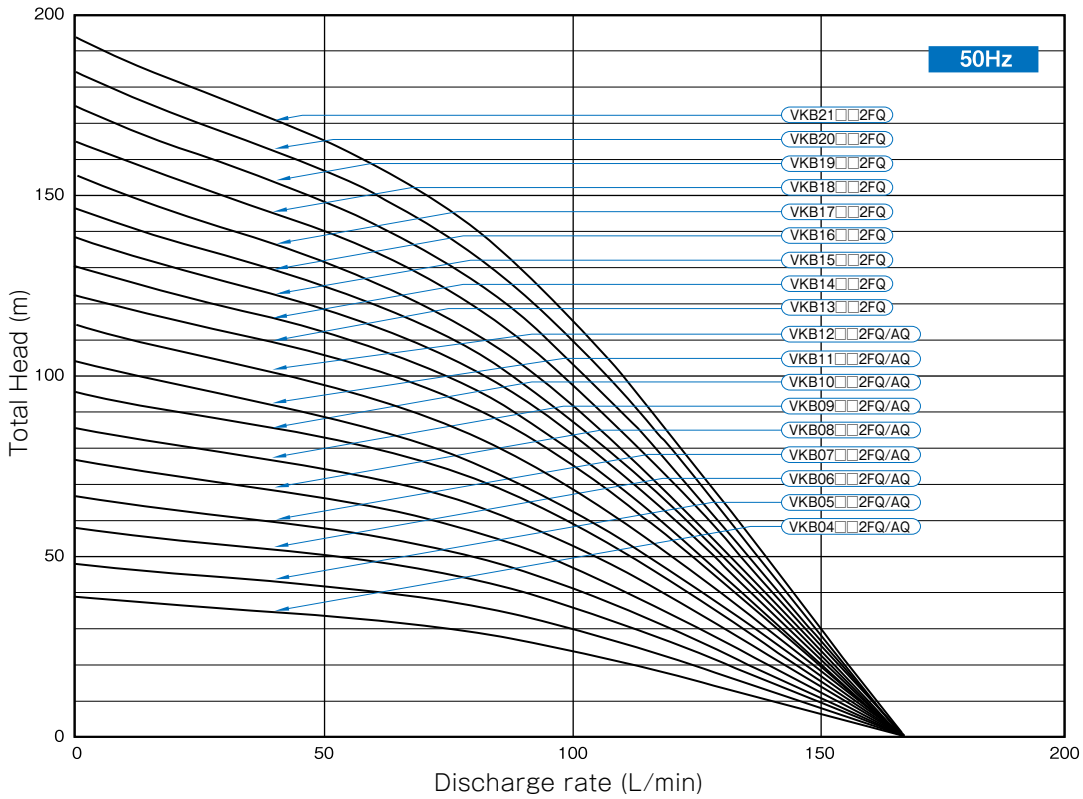

Note 1) The above characteristic curves reflect the full impeller condition of the units. The total head may be decreased depending on the flow rate if empty casings are involved because of pressure loss in the empty casings.

Note 2) Take note that discharge rate varies considerably depending on the type and kinematic viscosity of liquid. Above selection chart may not be used depending on the kinematic viscosity and specific gravity of the liquid.

■ Specification table

● VKB-H

· VKB-AH-e

Type	50Hz							60Hz						
	Rated voltage (V)	Nominal output (kW)	Rated current (A)	Starting current (A)	Discharge rate (L/min)	Total head (m)	Allowable kinematic viscosity (mm ² /s)	Rated voltage (V)	Nominal output (kW)	Rated current (A)	Starting current (A)	Discharge rate (L/min)	Total head (m)	Allowable kinematic viscosity (mm ² /s)
VKB05□□2AH-e	200	0.5	5.4	56	40	30	75	200/220	0.85	5.8/5.6	55/60	50	40	75
VKB06□□2AH-e		0.6	5.9	56	40	36			1.02	6.0/5.8	55/60	50	48	
VKB07□□2AH-e		0.7	6.2	56	40	42			1.19	6.0/5.8	55/60	50	56	
VKB08□□2AH-e		0.8	6.9	84	40	48			1.36	8.8/8.3	73/80	50	64	75
VKB09□□2AH-e		0.9	7.4	84	40	54			1.53	10.0/9.1	73/80	50	72	
VKB10□□2AH-e		1	12.0	180	40	60			1.7	10.3/10.6	152/167	50	80	
VKB11□□2AH-e		1.1	12.3	180	40	66			1.87	11.1/11.3	152/167	50	88	
VKB12□□2AH-e		1.2	12.5	180	40	72			2.04	11.7/11.8	152/167	50	96	
VKB13□□2AH-e		1.3	12.9	180	40	78			2.21	12.7/12.6	152/167	50	104	
VKB14□□2AH-e		1.4	13.1	180	40	84			2.38	13.5/13.2	152/167	50	112	
VKB15□□2AH-e		1.5	13.6	180	40	90			2.55	14.4/13.9	152/167	50	120	
VKB16□□2AH-e		1.6	14.0	180	40	96			2.72	15.3/14.6	152/167	50	128	
VKB17□□2AH-e		1.7	14.5	180	40	102			2.89	16.2/15.3	152/167	50	136	
VKB18□□2AH-e		1.8	15.2	180	40	108			3.06	16.2/15.3	152/167	50	144	
VKB19□□2AH-e		1.9	15.7	180	40	114			3.23	16.2/15.3	152/167	50	152	

Note) The pump's rated current (current value listed on the pump nameplate) is the recommended current setting for protection device.

· VKB-FH-e

Type	50H						
	Rated voltage (V)	Nominal output (kW)	Rated current (A)	Starting current (A)	Discharge rate (L/min)	Total head (m)	Allowable kinematic viscosity (mm ² /s)
VKB05□□2FH-e	200	0.5	3.6	30	40	30	1
VKB06□□2FH-e		0.6	4.0	30	40	36	
VKB07□□2FH-e		0.7	4.4	30	40	42	
VKB08□□2FH-e		0.8	5.8	56	40	48	
VKB09□□2FH-e		0.9	6.3	56	40	54	
VKB10□□2FH-e		1	6.4	56	40	60	
VKB11□□2FH-e		1.1	6.9	84	40	66	
VKB12□□2FH-e		1.2	7.2	84	40	72	
VKB13□□2FH-e		1.3	7.6	84	40	78	
VKB14□□2FH-e		1.4	8.0	84	40	84	
VKB15□□2FH-e		1.5	8.5	84	40	90	
VKB16□□2FH-e		1.6	9.0	84	40	96	
VKB17□□2FH-e		1.7	9.4	84	40	102	
VKB18□□2FH-e		1.8	10.0	84	40	108	
VKB19□□2FH-e		1.9	10.5	84	40	114	
VKB20□□2FH-e		2	13.3	180	40	120	
VKB21□□2FH-e		2.1	13.5	180	40	126	
VKB22□□2FH-e		2.2	13.8	180	40	132	
VKB23□□2FH-e		2.3	14.1	180	40	138	
VKB24□□2FH-e		2.4	14.5	180	40	144	
VKB25□□2FH-e		2.5	14.9	180	40	150	
VKB26□□2FH-e		2.6	15.4	180	40	156	

Note 1) The 50 Hz exclusive units are for use with water-soluble coolant liquids (1mm²/s kinematic viscosity) only. Contact us when your applications involve oil-based coolant liquids.

Note 2) The pump's rated current (current value listed on the pump nameplate) is the recommended current setting for protection device.

* Please inquire separately for China GB3 (GB18613-2020) compliant products.

●VKB-Q

· VKB-AQ-e

Type	50Hz							60Hz						
	Rated voltage (V)	Nominal output (kW)	Rated current (A)	Starting current (A)	Discharge rate (L/min)	Total head (m)	Allowable kinematic viscosity (mm ² /s)	Rated voltage (V)	Nominal output (kW)	Rated current (A)	Starting current (A)	Discharge rate (L/min)	Total head (m)	Allowable kinematic viscosity (mm ² /s)
VKB04□□2AQ-e	200	0.72	6.0	56	85	26	75	200/220	1.2	6.0/5.8	55/60	100	36	37.5
VKB05□□2AQ-e		0.9	7.0	84	85	33			1.5	8.8/8.3	73/80	100	46	75
VKB06□□2AQ-e		1.08	7.8	84	85	39			1.8	10.0/9.1	73/80	100	54	37.5
VKB07□□2AQ-e		1.26	12.4	180	85	45			2.1	11.3/11.4	152/167	100	63	75
VKB08□□2AQ-e		1.44	12.9	180	85	52			2.4	12.7/12.6	152/167	100	72	
VKB09□□2AQ-e		1.62	13.6	180	85	58			2.7	14.0/13.5	152/167	100	81	
VKB10□□2AQ-e		1.8	14.3	180	85	65			3	15.5/14.8	152/167	100	90	
VKB11□□2AQ-e		1.98	15.3	180	85	71			3.3	16.2/15.3	152/167	100	99	37.5
VKB12□□2AQ-e		2.16	16.3	180	85	78			3.6	16.2/15.3	152/167	100	108	

Note) The pump's rated current (current value listed on the pump nameplate) is the recommended current setting for protection device.

· VKB-FQ-e

Type	50Hz						
	Rated voltage (V)	Nominal output (kW)	Rated current (A)	Starting current (A)	Discharge rate (L/min)	Total head (m)	Allowable kinematic viscosity (mm ² /s)
VKB04□□2FQ-e	200	0.72	4.4	30	85	26	1
VKB05□□2FQ-e		0.9	6.0	56	85	33	
VKB06□□2FQ-e		1.08	6.4	56	85	39	
VKB07□□2FQ-e		1.26	6.8	84	85	45	
VKB08□□2FQ-e		1.44	7.6	84	85	52	
VKB09□□2FQ-e		1.62	8.4	84	85	58	
VKB10□□2FQ-e		1.8	9.2	84	85	65	
VKB13□□2FQ-e		2.34	13.7	180	85	84	
VKB14□□2FQ-e		2.52	14.2	180	85	91	
VKB15□□2FQ-e		2.7	14.8	180	85	97	
VKB16□□2FQ-e		2.88	15.6	180	85	104	
VKB17□□2FQ-e		3.06	16.3	180	85	110	
VKB18□□2FQ-e		3.24	16.9	180	85	117	
VKB19□□2FQ-e		3.42	17.4	180	85	123	
VKB20□□2FQ-e		3.6	17.4	180	85	130	
VKB21□□2FQ-e		3.78	17.4	180	85	136	

Note 1) The 50Hz exclusive units are for use with water-soluble coolant liquids (1mm²/s kinematic viscosity) only. Contact us when your applications involve oil-based coolant liquids.

Note 2) The pump's rated current (current value listed on the pump nameplate) is the recommended current setting for protection device.

* Please inquire separately for China GB3 (GB18613-2020) compliant products.

■ Assembly drawing

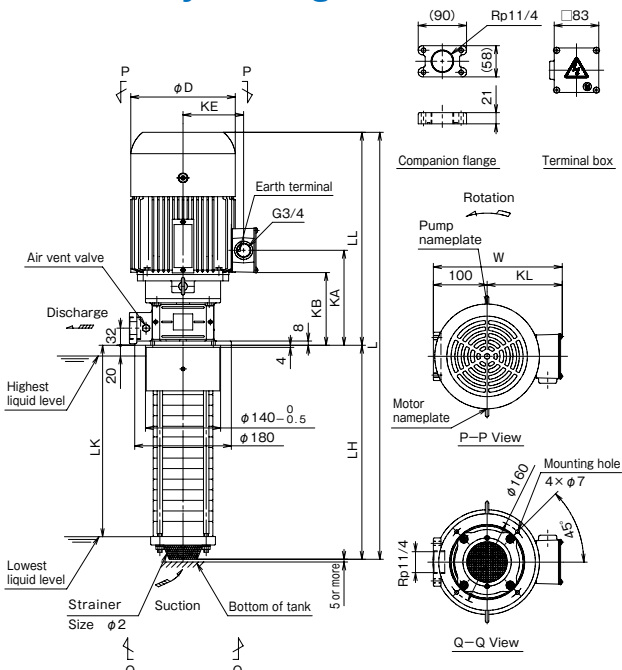

■ Detailed drawing of the terminal box

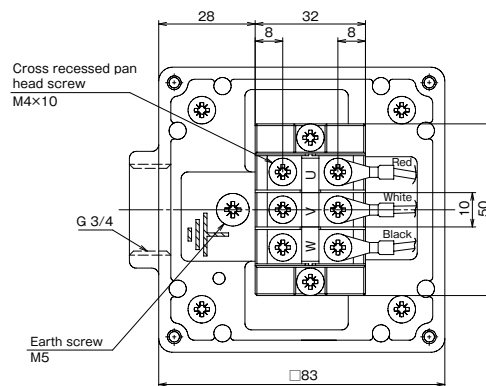

■ Dimensions

●VKB-H

• VKB-AH-e

(Unit : mm)

Type	L	LH	LK	Approx.mass (kg)
VKB05102AH-e	632	300	258	25
VKB05112AH-e	652	320	278	25
VKB05132AH-e	692	360	318	25
VKB05152AH-e	731	399	357	26
VKB05172AH-e	770	438	396	26
VKB05182AH-e	790	458	416	26
VKB06102AH-e	632	300	258	25
VKB06112AH-e	652	320	278	25
VKB06132AH-e	692	360	318	25
VKB06152AH-e	731	399	357	26
VKB06172AH-e	770	438	396	26
VKB06182AH-e	790	458	416	26
VKB07102AH-e	632	300	258	25
VKB07112AH-e	652	320	278	25
VKB07132AH-e	692	360	318	25
VKB07152AH-e	731	399	357	26
VKB07172AH-e	770	438	396	26
VKB07182AH-e	790	458	416	26
VKB08102AH-e	657	300	258	30
VKB08112AH-e	677	320	278	30
VKB08132AH-e	717	360	318	30
VKB08152AH-e	756	399	357	31
VKB08172AH-e	795	438	396	31
VKB08182AH-e	815	458	416	31
VKB08212AH-e	874	517	475	32
VKB08222AH-e	894	537	495	32
VKB08262AH-e	973	616	574	33
VKB09102AH-e	657	300	258	30
VKB09112AH-e	677	320	278	30
VKB09132AH-e	717	360	318	30
VKB09152AH-e	756	399	357	31
VKB09172AH-e	795	438	396	31
VKB09182AH-e	815	458	416	32
VKB09212AH-e	874	517	475	32
VKB09222AH-e	894	537	495	32
VKB09262AH-e	973	616	574	33
VKB10102AH-e	697	300	258	37
VKB10112AH-e	717	320	278	37
VKB10132AH-e	757	360	318	38
VKB10152AH-e	796	399	357	38
VKB10172AH-e	835	438	396	39
VKB10182AH-e	855	458	416	39
VKB10212AH-e	914	517	475	39
VKB10222AH-e	934	537	495	40
VKB10262AH-e	1013	616	574	41
VKB11112AH-e	717	320	278	37
VKB11132AH-e	757	360	318	38
VKB11152AH-e	796	399	357	38
VKB11172AH-e	835	438	396	39
VKB11182AH-e	855	458	416	39
VKB11212AH-e	914	517	475	39
VKB11222AH-e	934	537	495	40
VKB11262AH-e	1013	616	574	41

(Unit : mm)

Type	L	LH	LK	Approx.mass (kg)
VKB12122AH-e	737	340	298	38
VKB12132AH-e	757	360	318	38
VKB12152AH-e	796	399	357	38
VKB12172AH-e	835	438	396	39
VKB12182AH-e	855	458	416	39
VKB12202AH-e	894	497	455	39
VKB12222AH-e	934	537	495	40
VKB12262AH-e	1013	616	574	41
VKB13132AH-e	757	360	318	38
VKB13152AH-e	796	399	357	38
VKB13182AH-e	855	458	416	39
VKB13202AH-e	894	497	455	39
VKB13222AH-e	934	537	495	40
VKB13262AH-e	1013	616	574	41
VKB14142AH-e	776	379	337	38
VKB14152AH-e	796	399	357	38
VKB14182AH-e	855	458	416	39
VKB14192AH-e	875	478	436	39
VKB14202AH-e	894	497	455	39
VKB14222AH-e	934	537	495	40
VKB14262AH-e	1013	616	574	41
VKB15152AH-e	796	399	357	38
VKB15182AH-e	855	458	416	39
VKB15202AH-e	894	497	455	40
VKB15222AH-e	934	537	495	40
VKB15262AH-e	1013	616	574	41
VKB16162AH-e	816	419	377	39
VKB16182AH-e	855	458	416	39
VKB16202AH-e	894	497	455	40
VKB16222AH-e	934	537	495	40
VKB16262AH-e	1013	616	574	41
VKB17172AH-e	835	438	396	39
VKB17182AH-e	855	458	416	39
VKB17202AH-e	894	497	455	40
VKB17212AH-e	914	517	475	40
VKB17222AH-e	934	537	495	40
VKB17262AH-e	1013	616	574	41
VKB18182AH-e	855	458	416	39
VKB18202AH-e	894	497	455	40
VKB18212AH-e	914	517	475	40
VKB18222AH-e	934	537	495	40
VKB18242AH-e	973	576	534	41
VKB18252AH-e	993	596	554	41
VKB18262AH-e	1013	616	574	41
VKB19212AH-e	914	517	475	40
VKB19262AH-e	1013	616	574	41

(Unit : mm)

Number of impellers	D	KA	KB	KE	KL	LL	W
05~07	157	167	125	95	122	332	222
08~09	175	167	125	103	130	357	230
10~19	195	177	135	113	140	397	240

· VKB-FH-e

(Unit : mm)

Type	L	LH	LK	Approx.mass (kg)
VKB05102FH-e	612	300	258	21
VKB05112FH-e	632	320	278	20
VKB05132FH-e	672	360	318	21
VKB05152FH-e	711	399	357	21
VKB05182FH-e	770	458	416	22
VKB06102FH-e	612	300	258	21
VKB06112FH-e	632	320	278	21
VKB06132FH-e	672	360	318	21
VKB06152FH-e	711	399	357	21
VKB06182FH-e	770	458	416	22
VKB07102FH-e	612	300	258	21
VKB07112FH-e	632	320	278	21
VKB07132FH-e	672	360	318	21
VKB07152FH-e	711	399	357	22
VKB07172FH-e	750	438	396	22
VKB07182FH-e	770	458	416	22
VKB07222FH-e	849	537	495	23
VKB07262FH-e	928	616	574	24
VKB08102FH-e	632	300	258	25
VKB08112FH-e	652	320	278	25
VKB08132FH-e	692	360	318	25
VKB08152FH-e	731	399	357	26
VKB08172FH-e	770	438	396	26
VKB08182FH-e	790	458	416	27
VKB08212FH-e	849	517	475	27
VKB08222FH-e	869	537	495	27
VKB08262FH-e	948	616	574	28
VKB09102FH-e	632	300	258	25
VKB09112FH-e	652	320	278	25
VKB09132FH-e	692	360	318	26
VKB09152FH-e	731	399	357	26
VKB09172FH-e	770	438	396	26
VKB09182FH-e	790	458	416	27
VKB09212FH-e	849	517	475	27
VKB09222FH-e	869	537	495	28
VKB09262FH-e	948	616	574	28
VKB10102FH-e	632	300	258	25
VKB10112FH-e	652	320	278	25
VKB10132FH-e	692	360	318	26
VKB10152FH-e	731	399	357	26
VKB10172FH-e	770	438	396	26
VKB10182FH-e	790	458	416	27
VKB10212FH-e	849	517	475	27
VKB10222FH-e	869	537	495	28
VKB10262FH-e	948	616	574	28
VKB11112FH-e	677	320	278	30
VKB11132FH-e	717	360	318	31
VKB11152FH-e	756	399	357	31
VKB11172FH-e	795	438	396	31
VKB11182FH-e	815	458	416	32
VKB11212FH-e	874	517	475	32
VKB11222FH-e	894	537	495	33
VKB11262FH-e	973	616	574	33
VKB12122FH-e	697	340	298	30
VKB12132FH-e	717	360	318	31
VKB12152FH-e	756	399	357	31
VKB12172FH-e	795	438	396	32
VKB12182FH-e	815	458	416	32
VKB12212FH-e	854	497	455	32
VKB12222FH-e	894	537	495	33
VKB12262FH-e	973	616	574	34

(Unit : mm)

Type	L	LH	LK	Approx.mass (kg)
VKB13132FH-e	717	360	318	31
VKB13152FH-e	756	399	357	31
VKB13172FH-e	795	438	396	32
VKB13182FH-e	815	458	416	32
VKB13212FH-e	854	497	455	32
VKB13222FH-e	894	537	495	33
VKB13262FH-e	973	616	574	34
VKB14142FH-e	736	379	337	31
VKB14152FH-e	756	399	357	31
VKB14182FH-e	815	458	416	32
VKB14212FH-e	854	497	455	33
VKB14222FH-e	894	537	495	33
VKB14262FH-e	973	616	574	34
VKB15152FH-e	756	399	357	31
VKB15162FH-e	776	419	377	32
VKB15172FH-e	795	438	396	32
VKB15182FH-e	815	458	416	32
VKB15212FH-e	854	497	455	33
VKB15222FH-e	894	537	495	33
VKB15262FH-e	973	616	574	34
VKB16162FH-e	776	419	377	32
VKB16172FH-e	795	438	396	32
VKB16182FH-e	815	458	416	32
VKB16212FH-e	854	497	455	33
VKB16222FH-e	894	537	495	33
VKB16262FH-e	973	616	574	34
VKB17172FH-e	795	438	396	32
VKB17182FH-e	815	458	416	32
VKB17212FH-e	874	517	475	33
VKB17222FH-e	894	537	495	33
VKB17262FH-e	973	616	574	34
VKB18182FH-e	815	458	416	32
VKB18212FH-e	874	517	475	33
VKB18222FH-e	894	537	495	33
VKB18232FH-e	933	576	534	33
VKB18262FH-e	973	616	574	34
VKB19192FH-e	835	478	436	33
VKB19212FH-e	874	517	475	33
VKB19222FH-e	894	537	495	33
VKB19262FH-e	973	616	574	34
VKB20202FH-e	894	497	455	40
VKB20212FH-e	914	517	475	40
VKB20222FH-e	934	537	495	40
VKB20262FH-e	1013	616	574	41
VKB21212FH-e	914	517	475	40
VKB21222FH-e	934	537	495	41
VKB21262FH-e	1013	616	574	41
VKB22222FH-e	934	537	495	41
VKB22242FH-e	973	576	534	41
VKB22262FH-e	1013	616	574	41
VKB23232FH-e	953	556	514	41
VKB23262FH-e	1013	616	574	42
VKB24242FH-e	973	576	534	41
VKB24262FH-e	1013	616	574	42
VKB25252FH-e	993	596	554	41
VKB25262FH-e	1013	616	574	42
VKB26262FH-e	1013	616	574	42

(Unit : mm)

Number of impellers	D	KA	KB	KE	KL	LL	W
05~07	140	167	125	88	115	312	215
08~10	157	167	125	95	122	332	222
11~19	175	167	125	103	130	357	230
20~26	195	177	135	113	140	397	240

●VKB-Q

• VKB-AQ-e

(Unit : mm)

Type	L	LH	LK	Approx.mass (kg)
VKB04072AQ-e	623	291	249	24
VKB04082AQ-e	651	319	277	24
VKB04092AQ-e	679	347	305	24
VKB04102AQ-e	707	375	333	25
VKB04122AQ-e	763	431	389	25
VKB04142AQ-e	819	487	445	26
VKB04152AQ-e	847	515	473	26
VKB04162AQ-e	875	543	501	26
VKB04192AQ-e	959	627	585	27
VKB04222AQ-e	1043	711	669	28
VKB05072AQ-e	648	291	249	29
VKB05082AQ-e	676	319	277	29
VKB05092AQ-e	704	347	305	29
VKB05102AQ-e	732	375	333	30
VKB05122AQ-e	788	431	389	30
VKB05142AQ-e	844	487	445	31
VKB05152AQ-e	872	515	473	31
VKB05162AQ-e	900	543	501	31
VKB05192AQ-e	984	627	585	32
VKB05222AQ-e	1068	711	669	33
VKB06072AQ-e	648	291	249	29
VKB06082AQ-e	676	319	277	29
VKB06092AQ-e	704	347	305	30
VKB06102AQ-e	732	375	333	30
VKB06122AQ-e	788	431	389	30
VKB06142AQ-e	844	487	445	31
VKB06152AQ-e	872	515	473	31
VKB06162AQ-e	900	543	501	31
VKB06192AQ-e	984	627	585	32
VKB06222AQ-e	1068	711	669	33
VKB07072AQ-e	688	291	249	36
VKB07082AQ-e	716	319	277	37
VKB07092AQ-e	744	347	305	37
VKB07102AQ-e	772	375	333	37
VKB07122AQ-e	828	431	389	37
VKB07142AQ-e	884	487	445	38
VKB07152AQ-e	912	515	473	38
VKB07162AQ-e	940	543	501	38
VKB07192AQ-e	1024	627	585	39

(Unit : mm)

Number of impellers	D	KA	KB	KE	KL	LL	W
04	157	167	125	95	122	332	222
05~06	175	167	125	103	130	357	230
07~12	195	177	135	113	140	397	240

(Unit : mm)

Type	L	LH	LK	Approx.mass (kg)
VKB07222AQ-e	1108	711	669	40
VKB08082AQ-e	716	319	277	37
VKB08092AQ-e	744	347	305	37
VKB08102AQ-e	772	375	333	37
VKB08122AQ-e	828	431	389	38
VKB08142AQ-e	884	487	445	38
VKB08152AQ-e	912	515	473	38
VKB08162AQ-e	940	543	501	39
VKB08192AQ-e	1024	627	585	39
VKB08222AQ-e	1108	711	669	40
VKB09092AQ-e	744	347	305	37
VKB09102AQ-e	772	375	333	37
VKB09122AQ-e	828	431	389	38
VKB09142AQ-e	884	487	445	38
VKB09152AQ-e	912	515	473	38
VKB09162AQ-e	940	543	501	39
VKB09192AQ-e	1024	627	585	39
VKB09222AQ-e	1108	711	669	40
VKB10102AQ-e	772	375	333	37
VKB10122AQ-e	828	431	389	38
VKB10142AQ-e	884	487	445	38
VKB10152AQ-e	912	515	473	39
VKB10162AQ-e	940	543	501	39
VKB10192AQ-e	1024	627	585	39
VKB10222AQ-e	1108	711	669	40
VKB11112AQ-e	800	403	361	38
VKB11122AQ-e	828	431	389	38
VKB11142AQ-e	884	487	445	38
VKB11152AQ-e	912	515	473	39
VKB11162AQ-e	940	543	501	39
VKB11192AQ-e	1024	627	585	40
VKB11222AQ-e	1108	711	669	40
VKB12122AQ-e	828	431	389	38
VKB12142AQ-e	884	487	445	38
VKB12152AQ-e	912	515	473	39
VKB12162AQ-e	940	543	501	39
VKB12192AQ-e	1024	627	585	40
VKB12222AQ-e	1108	711	669	40

· VKB-FQ-e

(Unit : mm)

Type	L	LH	LK	Approx.mass (kg)
VKB04072FQ-e	603	291	249	20
VKB04082FQ-e	631	319	277	20
VKB04102FQ-e	687	375	333	20
VKB04122FQ-e	743	431	389	21
VKB04142FQ-e	799	487	445	21
VKB04162FQ-e	855	543	501	22
VKB04192FQ-e	939	627	585	23
VKB04222FQ-e	1023	711	669	23
VKB05072FQ-e	623	291	249	24
VKB05082FQ-e	651	319	277	24
VKB05102FQ-e	707	375	333	25
VKB05122FQ-e	763	431	389	25
VKB05142FQ-e	819	487	445	26
VKB05162FQ-e	875	543	501	26
VKB05192FQ-e	959	627	585	27
VKB05222FQ-e	1043	711	669	28
VKB06072FQ-e	623	291	249	24
VKB06082FQ-e	651	319	277	24
VKB06102FQ-e	707	375	333	25
VKB06122FQ-e	763	431	389	25
VKB06142FQ-e	819	487	445	26
VKB06162FQ-e	875	543	501	26
VKB06192FQ-e	959	627	585	27
VKB06222FQ-e	1043	711	669	28
VKB07072FQ-e	648	291	249	29
VKB07082FQ-e	676	319	277	29
VKB07102FQ-e	732	375	333	30
VKB07122FQ-e	788	431	389	30
VKB07142FQ-e	844	487	445	31
VKB07162FQ-e	900	543	501	31
VKB07192FQ-e	984	627	585	32
VKB07222FQ-e	1068	711	669	33
VKB08082FQ-e	676	319	277	30
VKB08102FQ-e	732	375	333	30
VKB08122FQ-e	788	431	389	30
VKB08142FQ-e	844	487	445	31
VKB08162FQ-e	900	543	501	31
VKB08192FQ-e	984	627	585	32
VKB08222FQ-e	1068	711	669	33
VKB09092FQ-e	704	347	305	30
VKB09102FQ-e	732	375	333	30

(Unit : mm)

Type	L	LH	LK	Approx.mass (kg)
VKB09122FQ-e	788	431	389	31
VKB09142FQ-e	844	487	445	31
VKB09162FQ-e	900	543	501	32
VKB09192FQ-e	984	627	585	32
VKB09222FQ-e	1068	711	669	33
VKB10102FQ-e	732	375	333	30
VKB10122FQ-e	788	431	389	31
VKB10142FQ-e	844	487	445	31
VKB10162FQ-e	984	627	585	32
VKB10192FQ-e	1012	655	613	32
VKB10222FQ-e	1068	711	669	33
VKB13132FQ-e	856	459	417	38
VKB13142FQ-e	884	487	445	39
VKB13162FQ-e	940	543	501	39
VKB13192FQ-e	1024	627	585	40
VKB13202FQ-e	1052	655	613	40
VKB13222FQ-e	1108	711	669	41
VKB14142FQ-e	884	487	445	39
VKB14162FQ-e	940	543	501	39
VKB14192FQ-e	1024	627	585	40
VKB14222FQ-e	1108	711	669	41
VKB15152FQ-e	912	515	473	39
VKB15162FQ-e	940	543	501	39
VKB15192FQ-e	1024	627	585	40
VKB15222FQ-e	1108	711	669	41
VKB16162FQ-e	940	543	501	39
VKB16192FQ-e	1024	627	585	40
VKB16222FQ-e	1108	711	669	41
VKB17172FQ-e	968	571	529	40
VKB17192FQ-e	1024	627	585	40
VKB17222FQ-e	1108	711	669	41
VKB18182FQ-e	996	599	557	40
VKB18192FQ-e	1024	627	585	40
VKB18222FQ-e	1108	711	669	41
VKB19192FQ-e	1024	627	585	40
VKB19222FQ-e	1108	711	669	41
VKB20202FQ-e	1052	655	613	41
VKB20222FQ-e	1108	711	669	41
VKB21212FQ-e	1080	683	641	41
VKB21222FQ-e	1108	711	669	41

(Unit : mm)

Number of impellers	D	KA	KB	KE	KL	LL	W
04	140	167	125	88	115	312	215
05~06	157	167	125	95	122	332	222
07~10	175	167	125	103	130	357	230
13~21	195	177	135	113	140	397	240

Sectional drawing

●VKB-H

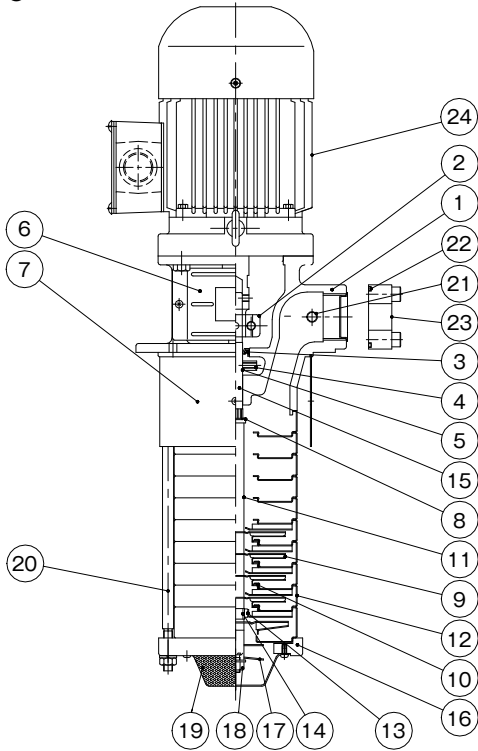

No.	Part name	Material
1	Pump leg	FC200
2	Coupling	S45C
3	Oil seal	NBR
4	Oil thrower	SUS304
5	O-ring	FKM
6	Coupling guard	SUS304
7	Outer casing	SUS304
8	Washer	SUS403
9	Impeller	SUS304
10	Seal ring	PTFE
11	Collar	SUS304
12	Casing	SUS304
13	Bearing ring	CERAMIC
14	Sleeve	WC
15	Main shaft (motor side+pump side)	S35C+SUS316
16	Suction chamber	FC200
17	Screw	SUS304
18	U-nut	SUS304
19	Wide strainer	SUS304
20	Fastening bolt	SUS304
21	Air vent valve	BRASS
22	O-ring	FKM
23	Companion flange	FC150
24	Motor	—

Note 1) The materials in the table above are equivalents.
Note 2) Structure and other details are subject to change without notice.

●VKB-Q

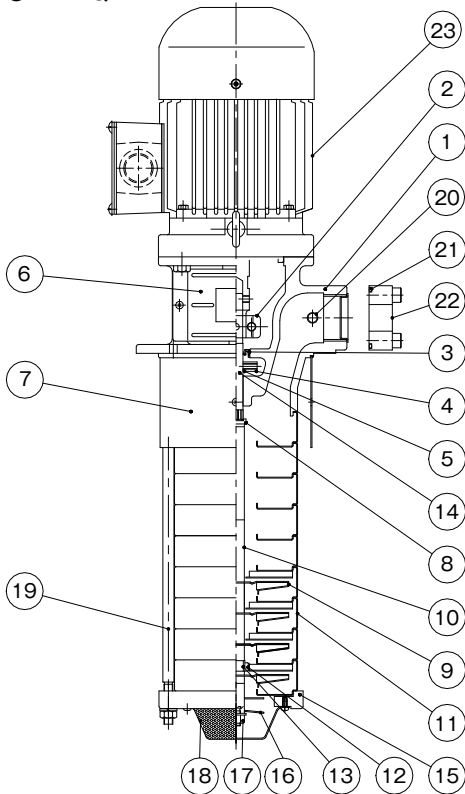

No.	Part name	Material
1	Pump leg	FC200
2	Coupling	S45C
3	Oil seal	NBR
4	Oil thrower	SUS304
5	O-ring	FKM
6	Coupling guard	SUS304
7	Outer casing	SUS304
8	Washer	SUS403
9	Impeller	SUS304
10	Collar	SUS304
11	Casing	SUS304
12	Bearing ring	CERAMIC
13	Sleeve	WC
14	Main shaft (motor side+pump side)	S35C+SUS316
15	Suction chamber	FC200
16	Screw	SUS304
17	U-nut	SUS304
18	Wide strainer	SUS304
19	Fastening bolt	SUS304
20	Air vent valve	BRASS
21	O-ring	FKM
22	Companion flange	FC150
23	Motor	—

Note 1) The materials in the table above are equivalents.
Note 2) Structure and other details are subject to change without notice.

Features

- ① Non-seal (mechanical seal-less) structure is adopted.
- ② Stainless steel is used in the pump's main liquid contact part and SiC bearings with increased wear resistance are adopted.
- ③ Measures against air suction into the pump are taken when the fluid level lowers.
- ④ Energy saving by high efficiency impeller!
Power consumption decreases by 20% compared to conventional models!
- ⑤ The lineup including the models complying with global standards by supporting efficiency and other regulations.
 - Japan : Top Runner efficiency
 - Europe : IE3 efficiency, CE marking(EU Directive)
RoHS Directive (2011/65/EU), 10 restricted substances
 - USA : NEMA Premium efficiency (IE3 efficiency), UL standards (safety)
 - Korea : Energy Efficiency Label and Standard Program (IE3)
 - Canada : CSA standard (efficiency), CSA standard (safety)
 - China : GB3 (GB18613-2020)
- ⑥ The mounting dimension is compatible with conventional models.



Please note that the paint color, etc. of the actual unit may partially differ from the photo.

Non-seal structure

TERAL's original "non-seal" structure allows coolant to flow from a narrow clearance without using a seal between the pump section and the motor section.

The advantages of a non-seal pump

- 1 No trouble such as coolant leaks.**
Helps cut down on running costs.
- 2 Prevents air entrainment.**
Reduces initial problems.
- 3 Not easily affected by a small quantity of liquid or shut-off operations.**
Enables a flexible operation system.

※What is non-seal structure?

This structure inwardly releases coolant by depressurizing through a narrow clearance without the use of a mechanical seal.

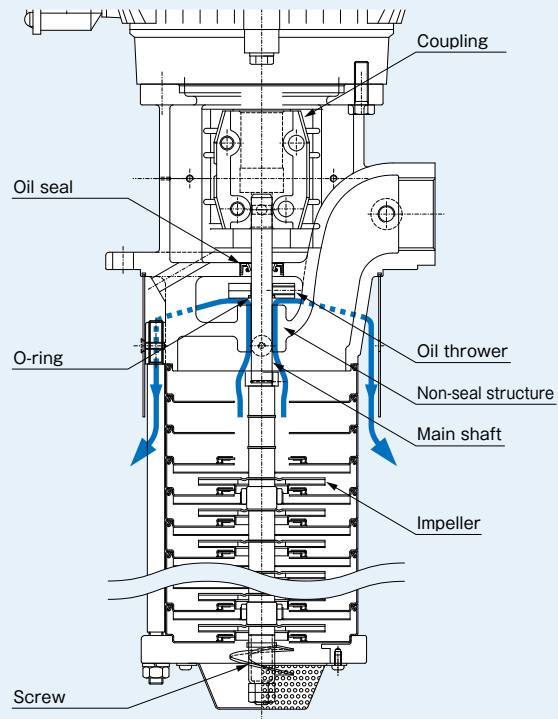

Description of types

50 LVS 10 - 20 / 12 - 6 7.5 -e

① ② ③ ④ ⑤ ⑥ ⑦ ⑧

- ① Discharge diameter
- ② Model
- ③ Nominal flow rate (m³/h)
- ④ Number of casings
- ⑤ Number of impellers
- ⑥ Frequency 5 : 50Hz 6 : 60Hz
- ⑦ Output
- ⑧ Motor efficiency
 - e : Top Runner efficiency (equivalent to IE3)
 - 7W: Equipped with NEMA Premium efficiency, UL/CSA certified motor (Output less than 0.75kW complies to safety standards only)
 - KS : Equipped with Korea Energy Efficiency Label and Standard Program compliant motor (IE3)

Global standards

Type	Standards/Regulations	Output	
		0.75kW-7.5kW	11kW-18.5kW
LVS-e	Top Runner efficiency (IE3 equivalent)	●	●
	CE Marking EU energy efficiency	●	
	GB3(GB18613-2020)	● ^{※1}	
LVS-7W	UL Standards (safety) NEMA Premium efficiency	●	
	Canada CSA standard (efficiency, safety)	●	
LVS-KS	Energy Efficiency Label and Standard Program (IE3)	●	

※1 GB certification label is attached as exclusive for GB standard. ● : Compliant

Standard Specification

Used liquid	Property of liquid	Water soluble coolants (e.g. grinding liquid, cutting liquid after secondary treatment) *1
	Temperature	0 to 90° C (No frozen liquid)
	Allowable kinematic viscosity	1mm ² /s
Installation location		Indoor Ambient temperature: 0 to 40° C. RH 85% or below (no condensation). Height above sea level : 1000m or less, Place not exposed to direct sunlight. Place in an area free of corrosive or explosive gas or vapor.
Material	Suction/Discharge casing	FC200
	Intermediate casing	SUS304
	Impeller	SUS304
	Main shaft	SUS420J2
Shaft seal structure		Non-seal (mechanical seal-less)
Motor	Type	Totally enclosed fan-cooled outdoor type *2
	Protection method	IP55
	Power source	3-phase 50/60/60Hz, 200/200/230V 0.75~7.5kW *3 3-phase 50/60/60Hz, 200/200/220V 11~18.5kW
	Thermal class	F *4
	Number of poles	2P
	Standard	IEC60034-1
Paint color	Pump	Munsell N1
	Motor	Black

*1 If the liquid contains hard sludge, such as abrasive powder, ground powder, or ground diamond grains, the service life might be shortened. Please set up a filter (magnet filter or paper filter, etc.). Take note that water cannot be used. Contact us for other special liquid (pure water, alkali-acid liquid, ceramic, etc.).

*2 The pump cannot be installed outside.

*3 Korea Energy Efficiency Label and Standard Program (IE3)/NEMA Premium efficiency (IE3), UL Standards (safety) : 3-phase 60Hz 200V-230V, GB18613-2020: 3-phase 50Hz 200V, 50Hz 380V

*4 Thermal class of -7W type is class A.

Special specification

Motor modifications	Voltage change *1, change of terminal box position *2, change of terminal box direction *3
Change of structure	Stainless steel suction casing *4

*1 7.5kW or less (50Hz/380V,400V 60Hz/400V 460V)

11kW or more(50Hz/380V,400V,415V,420V,440V 60Hz/400V,440V,460V,480V)

*2 Change of terminal box position (every 90° when viewed from above)

*3 Terminal box direction (every 90° when viewed from front), Applicable: 1.5 kW to 18.5 kW

*4 "-SU" is appended to the end of model type.

Note: The pump is not 100% made of stainless steel. Discharge casings and companion flanges are made of cast iron.

Special accessory

Companion flange (discharge diameter 32 mm)

Table of Consumable Parts

Output (kW)	Bearing		Oil seal				O-ring (For oil thrower) Material: FKM		
	Load side	Unload side	Motor		Discharge casing		Bore diameter 32	Bore diameter 50	
			Load side (Bearing side)	Unload side	Bore diameter 32	Bore diameter 50			
0.75	6204ZZC3	6201ZZC3	—	—	IS12257	SC16328	S12	S16	
1.1		6304ZZC3	—	VC20407					
1.5	VC25407		VC20407						
2.2				VC35557					VC25477
3.0	6307ZZC3		6305ZZC3	VC35527					VC25407
4.0	6309ZZC3		6306ZZC3	VC45628					VC30528
5.5				7309B					6309ZZC3
7.5									
11									
15									
18.5									

Selection chart

(Values at kinematic viscosity 1mm²/s, specific gravity 1)

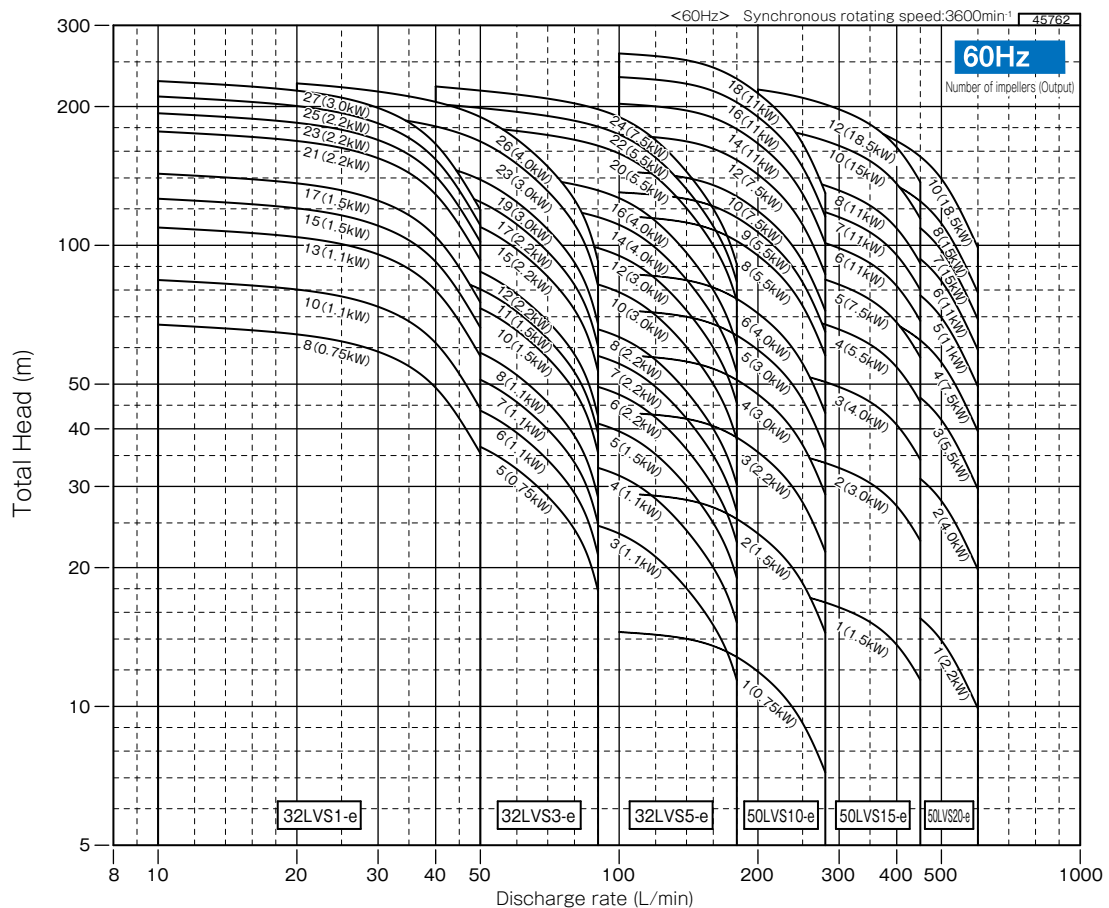
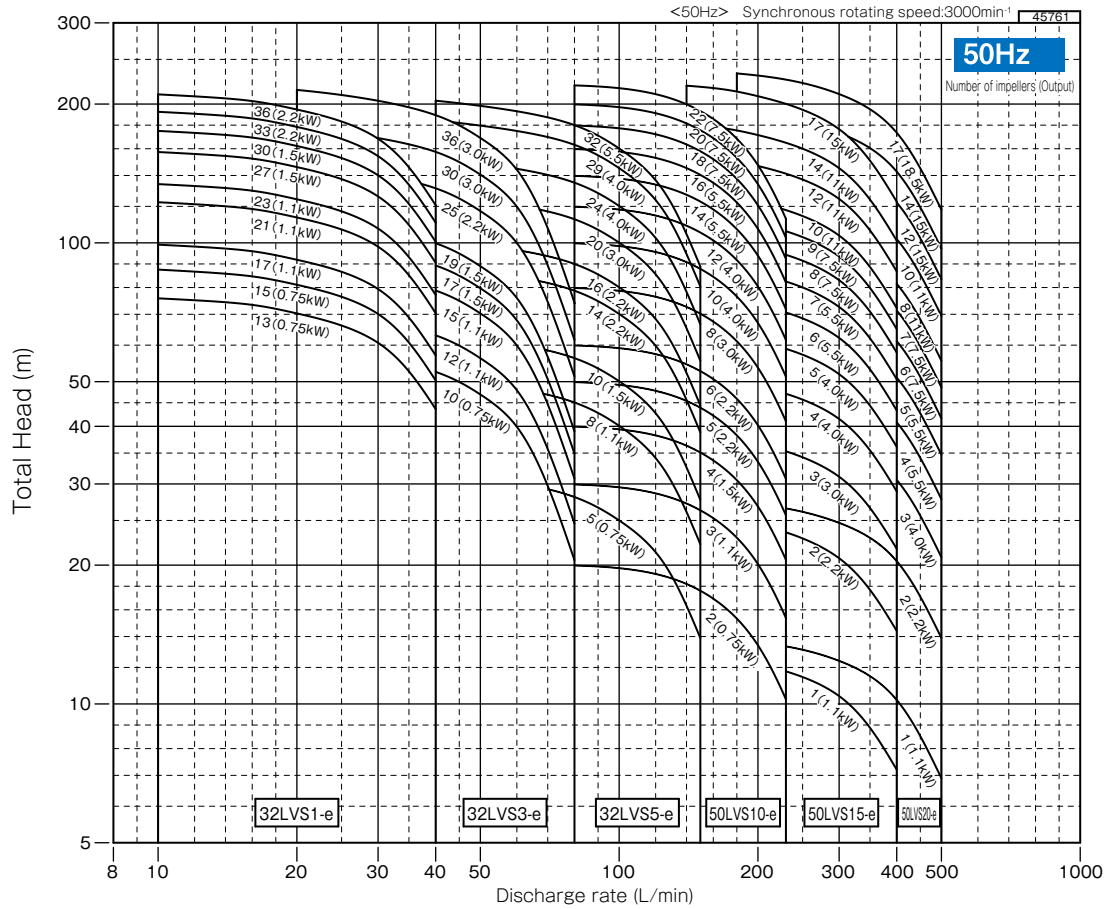

Note 1) The selection chart reflects the full impeller condition of the units. The total head may be decreased depending on the flow rate if empty casings are involved because of pressure loss in the empty casings.

* Above selection chart (-e) is also available for -KS/-7W type.

■ Pressure loss in the empty casings (50 Hz/60 Hz)

Pressure loss for 1 stage of empty casing is as follows:

LVS1

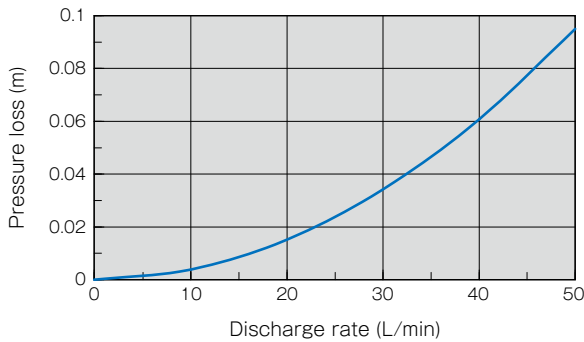

LVS10

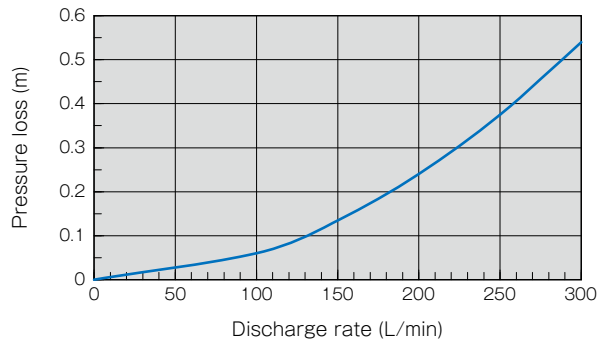

LVS3

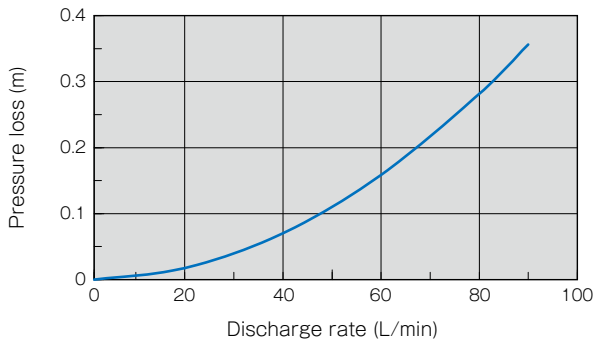

LVS15

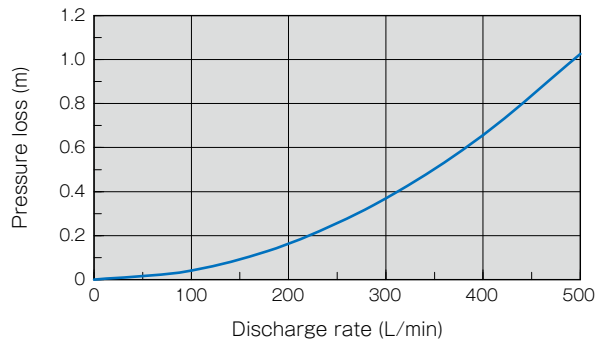

LVS5

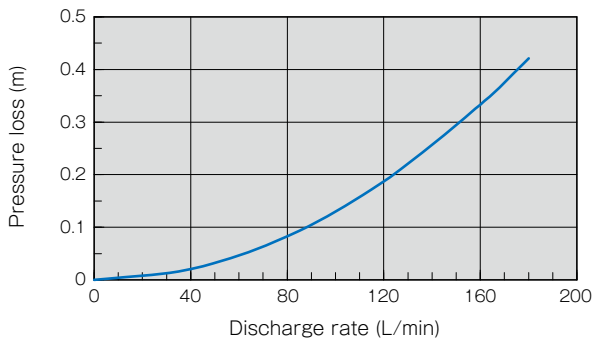

LVS20

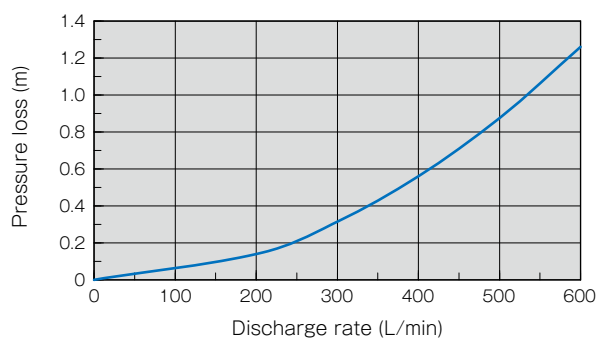

The selection chart is a performance chart of the full-impeller model (all casings are equipped with impeller). A pump with empty casings (without impeller) will have some influence on the total head of the pump depending on the flow rate due to its pressure loss.

The pressure loss per 1 stage of empty casing of each model is as shown in the graph above.

In the case of a pump with many stages of empty casings, the maximum flow rate may slightly decrease.

For details, refer to the characteristic curve chart.

● Calculation example of total pump head in consideration of pressure loss of empty casing

- Pump type : 32LVS5-20/5-5.75-e
- Specification flow rate : 100L/min
- Specification total head : 20m
- The number of stages : 20
- Number of impellers : 5

From the graph above, the pressure loss per 1 stage of empty casing is 0.13 m for a flow rate of 100L/min

The number of stages of the empty casing is 20 - 5 = 15 stages.

Total pressure loss = 0.13 × 15 = 2.0m

From the selection chart, the total head is 25 m for a flow rate of 100L/min.

The pressure loss is subtracted from the total head.

Total head = 25 - 2.0 = 23.0m

Therefore, the total head of 32LVS5-20/5-5.75-e is 23.0 m for a flow rate of 100 L/min.

■ Specification table

●-e type

50Hz

Bore diameter (mm)	Nominal flow rate (m ³ /h)	Type	Output (kW)	Rated voltage (V)	Rated current (A)	Starting current (A)	Discharge rate (L/min)	Total Head (m)				
32	1	32LVS1-□/13-5.75-e	0.75	200	3.4	26	10-40	75.5 - 43.5				
		32LVS1-□/15-5.75-e						87 - 50				
		32LVS1-□/17-51.1-e	1.1					4.7	34	99 - 56.5		
		32LVS1-□/21-51.1-e								122 - 70		
		32LVS1-□/23-51.1-e	1.5					6.2	47	134 - 77		
		32LVS1-□/27-51.5-e								157 - 90		
		32LVS1-□/30-51.5-e	2.2					8.7	83	174.5 - 100.5		
		32LVS1-□/33-52.2-e								192 - 110.5		
	32LVS1-36/36-52.2-e					209.5 - 120.5						
	3	3	32LVS3-□/10-5.75-e		0.75	3.4	26	20-80	59.5 - 20.5			
			32LVS3-□/12-51.1-e		1.1	4.7	34		71.5 - 24.5			
			32LVS3-□/15-51.1-e						89 - 30.5			
			32LVS3-□/17-51.5-e		1.5	6.2	47		101 - 34.5			
			32LVS3-□/19-51.5-e						113 - 38.5			
			32LVS3-□/25-52.2-e		2.2	8.7	83		149 - 51			
			32LVS3-□/30-53.0-e						178.5 - 61.5			
			32LVS3-36/36-53.0-e		3.0	12.2	129		214.5 - 73.5			
			5		5	32LVS5-□/5-5.75-e	0.75		3.4	26	40-150	31.5 - 13.5
						32LVS5-□/8-51.1-e	1.1		4.7	34		50.5 - 22
						32LVS5-□/10-51.5-e	1.5		6.2	47		63 - 27.5
						32LVS5-□/14-52.2-e						88.5 - 38.5
	32LVS5-□/16-52.2-e	2.2				8.7	83	101 - 44				
	32LVS5-□/20-53.0-e							126.5 - 55				
	32LVS5-□/24-54.0-e	4.0				14.7	145	152 - 66.5				
32LVS5-□/29-54.0-e	183.5 - 80											
32LVS5-32/32-55.5-e	5.5	20.3	204	202.5 - 88.5								
50	10	50LVS10-□/2-5.75-e	0.75	3.4	26	80-230	19.5 - 9					
		50LVS10-□/3-51.1-e	1.1	4.7	34		29.5 - 15					
		50LVS10-□/4-51.5-e	1.5	6.2	47		39.5 - 20.5					
		50LVS10-□/5-52.2-e	2.2	8.7	83		49.5 - 26					
		50LVS10-□/6-52.2-e					59.5 - 31					
		50LVS10-□/8-53.0-e	3.0	12.2	129		79.5 - 41.5					
		50LVS10-□/10-54.0-e					99.5 - 52					
		50LVS10-□/12-54.0-e	4.0	14.7	145		119.5 - 62.5					
		50LVS10-□/14-55.5-e					139.5 - 73					
		50LVS10-□/16-55.5-e	5.5	20.3	204		159.5 - 83.5					
		50LVS10-□/18-57.5-e					179.5 - 94					
		50LVS10-□/20-57.5-e	7.5	27.2	290		199.5 - 104.5					
	50LVS10-22/22-57.5-e	219 - 114.5										
	15	15	50LVS15-□/1-51.1-e	1.1	4.7	34	140-400	12.5 - 5.5				
			50LVS15-□/2-52.2-e	2.2	8.7	83		25.5 - 13.5				
			50LVS15-□/3-53.0-e	3.0	12.2	129		38.5 - 21.5				
			50LVS15-□/4-54.0-e	4.0	14.7	145		51.5 - 28.5				
			50LVS15-□/5-54.0-e					64.5 - 36				
			50LVS15-□/6-55.5-e	5.5	20.3	204		77 - 43				
			50LVS15-□/7-55.5-e					90 - 50.5				
			50LVS15-□/8-57.5-e	7.5	27.2	290		103 - 57.5				
			50LVS15-□/9-57.5-e					116 - 65				
			50LVS15-□/10-511-e	11	40.5	361		129 - 72				
			50LVS15-□/12-511-e					154.5 - 86.5				
			50LVS15-□/14-511-e	15	54.0	484		180.5 - 101				
	50LVS15-17/17-515-e	219 - 122.5										
	20	20	50LVS20-□/1-51.1-e	1.1	4.7	34	180-500	13 - 5				
			50LVS20-□/2-52.2-e	2.2	8.7	83		27 - 13				
			50LVS20-□/3-54.0-e	4.0	14.7	145		41 - 20.5				
			50LVS20-□/4-55.5-e	5.5	20.3	204		54.5 - 27.5				
			50LVS20-□/5-55.5-e					68.5 - 34.5				
			50LVS20-□/6-57.5-e	7.5	27.2	290		82 - 41.5				
			50LVS20-□/7-57.5-e					95.9 - 48.5				
			50LVS20-□/8-511-e	11	40.5	361		109.5 - 55.5				
			50LVS20-□/10-511-e					137 - 69				
			50LVS20-□/12-515-e	15	54.0	484		163 - 83				
50LVS20-□/14-515-e			191.5 - 97									
50LVS20-17/17-518-e			18.5	66.0	563	232.5 - 117.5						

Note) The rated current in the table above is the recommended setting for the current value of the protective device.

●-e (380V)

50Hz

Bore diameter (mm)	Nominal flow rate (m ³ /h)	Type	Output (kW)	Rated voltage (V)	Rated current (A)	Starting current (A)	Discharge rate (L/min)	Total head (m)	
32	1	32LVS1-□/13-5.75-e	0.75	380	1.7	12.5	10-40	75.5 - 43.5	
		32LVS1-□/15-5.75-e						87 - 50	
		32LVS1-□/17-51.1-e	1.1		2.4	16.3		99 - 56.5	
		32LVS1-□/21-51.1-e						122 - 70	
		32LVS1-□/23-51.1-e	1.5		3.2	22.4		134 - 77	
		32LVS1-□/27-51.5-e						157 - 90	
		32LVS1-□/30-51.5-e	2.2		4.5	38		174.5 - 100.5	
		32LVS1-□/33-52.2-e						192 - 110.5	
	32LVS1-36/36-52.2-e					209.5 - 120.5			
	3	32LVS3-□/10-5.75-e	0.75		1.7	12.5	20-80	59.5 - 20.5	
			32LVS3-□/12-51.1-e		1.1	2.4		16.3	71.5 - 24.5
		32LVS3-□/15-51.1-e	89 - 30.5						
		32LVS3-□/17-51.5-e	1.5		3.2	22.4		101 - 34.5	
		32LVS3-□/19-51.5-e						113 - 38.5	
		32LVS3-□/25-52.2-e	2.2		4.5	38		149 - 51	
		32LVS3-□/30-53.0-e	3.0		6.3	60.5		178.5 - 61.5	
		32LVS3-36/36-53.0-e						214.5 - 73.5	
	5	32LVS5-□/5-5.75-e	0.75		1.7	12.5	40-150	31.5 - 13.5	
			32LVS5-□/8-51.1-e		1.1	2.4		16.3	50.5 - 22
		32LVS5-□/10-51.5-e	1.5						3.2
		32LVS5-□/14-52.2-e	2.2		4.5	38		88.5 - 38.5	
		32LVS5-□/16-52.2-e						101 - 44	
		32LVS5-□/20-53.0-e	3.0		6.3	60.5		126.5 - 55	
		32LVS5-□/24-54.0-e	4.0		7.7	69		152 - 66.5	
		32LVS5-□/29-54.0-e						183.5 - 80	
	32LVS5-32/32-55.5-e	5.5	10.6		96.5	202.5 - 88.5			
	50	10	50LVS10-□/2-5.75-e		0.75	1.7	12.5	80-230	19.5 - 9
			50LVS10-□/3-51.1-e		1.1	2.4	16.3		29.5 - 15
50LVS10-□/4-51.5-e			1.5	3.2	22.4	39.5 - 20.5			
50LVS10-□/5-52.2-e			2.2	4.5	38	49.5 - 26			
50LVS10-□/6-52.2-e						59.5 - 31			
50LVS10-□/8-53.0-e			3.0	6.3	60.5	79.5 - 41.5			
50LVS10-□/10-54.0-e			4.0	7.7	69	99.5 - 52			
50LVS10-□/12-54.0-e						119.5 - 62.5			
50LVS10-□/14-55.5-e			5.5	10.6	96.5	139.5 - 73			
50LVS10-□/16-55.5-e						159.5 - 83.5			
50LVS10-□/18-57.5-e			7.5	14.2	137	179.5 - 94			
50LVS10-□/20-57.5-e						199.5 - 104.5			
50LVS10-22/22-57.5-e					219 - 114.5				
15		50LVS15-□/1-51.1-e	1.1	2.4	16.3	140-400	12.5 - 5.5		
			50LVS15-□/2-52.2-e	2.2	4.5		38	25.5 - 13.5	
		50LVS15-□/3-53.0-e	3.0	6.3	60.5		38.5 - 21.5		
		50LVS15-□/4-54.0-e	4.0	7.7	69		51.5 - 28.5		
		50LVS15-□/5-54.0-e					64.5 - 36		
		50LVS15-□/6-55.5-e	5.5	10.6	96.5		77 - 43		
		50LVS15-□/7-55.5-e					90 - 50.5		
		50LVS15-□/8-57.5-e	7.5	14.2	137		103 - 57.5		
50LVS15-□/9-57.5-e		116 - 65							
20		50LVS20-□/1-51.1-e	1.1	2.4	16.3	180-500	13 - 5		
			50LVS20-□/2-52.2-e	2.2	4.5		38	27 - 13	
		50LVS20-□/3-54.0-e	4.0	7.7	69		41 - 20.5		
		50LVS20-□/4-55.5-e	5.5	10.6	96.5		54.5 - 27.5		
		50LVS20-□/5-55.5-e					68.5 - 34.5		
		50LVS20-□/6-57.5-e	7.5	14.2	137		82 - 41.5		
	50LVS20-□/7-57.5-e	95.5 - 48.5							

Note 1) Contact us when your applications involve oil-based coolant liquid or special liquid (e.g. pure water, alkaline/acidic liquids).
 Note 2) The rated current is the recommended current setting for the protection device.

●-e type

60Hz

Bore diameter (mm)	Nominal flow rate (m ³ /h)	Type	Output (kW)	Rated voltage (V)	Rated current (A)	Starting current (A)	Discharge rate (L/min)	Total Head (m)	
32	1	32LVS1-□/8-6.75-e	0.75	200/230	3.2/3.1	25.0/28.5	10-50	67 - 35	
		32LVS1-□/10-61.1-e	1.1		4.4/4.1	32.5/37.0		84 - 44	
		32LVS1-□/13-61.1-e			109 - 57				
		32LVS1-□/15-61.5-e	1.5		5.9/5.4	41.0/47.6		126 - 66	
		32LVS1-□/17-61.5-e			142.5 - 75				
		32LVS1-□/21-62.2-e	2.2		8.4/7.6	78.0/82.6		176.5 - 92.5	
		32LVS1-□/23-62.2-e			193 - 101.5				
		32LVS1-□/25-62.2-e			210 - 110.5				
	32LVS1-□/27-63.0-e	227 - 119							
	3	32LVS3-□/5-6.75-e	0.75		3.2/3.1	25.0/28.5	20-90	43 - 17.5	
			32LVS3-□/6-61.1-e		1.1	4.4/4.1		32.5/37.0	51.5 - 21
		32LVS3-□/7-61.1-e	60 - 24.5						
		32LVS3-□/8-61.1-e	1.5		5.9/5.4	41.0/47.6		69 - 28	
		32LVS3-□/10-61.5-e			86 - 35.5				
		32LVS3-□/11-61.5-e	2.2		8.4/7.6	78.0/82.6		94.5 - 39	
		32LVS3-□/12-62.2-e			103.5 - 42.5				
		32LVS3-□/15-62.2-e	3.0		11.5/10.8	115/135		129.5 - 53	
		32LVS3-□/17-62.2-e			146.5 - 60				
		5	32LVS5-□/3-61.1-e		0.75	3.2/3.1		25.0/28.5	40-180
	32LVS5-□/4-61.1-e				1.1	4.4/4.1	32.5/37.0	198.5 - 81.5	
	32LVS5-□/5-61.5-e		1.5			5.9/5.4	41.0/47.6	224.5 - 92	
	32LVS5-□/6-62.2-e				2.2	8.4/7.6	78.0/82.6	27.5 - 11	
	32LVS5-□/7-62.2-e		36.5 - 15						
	32LVS5-□/8-62.2-e		3.0		11.5/10.8	115/135	46 - 18.5		
	32LVS5-□/10-63.0-e				55 - 22.5				
	32LVS5-□/12-63.0-e		4.0		14.3/12.8	132/151	64 - 26.5		
	32LVS5-□/14-64.0-e				73.5 - 30				
	32LVS5-□/16-64.0-e		5.5		19.8/17.8	178/206	92 - 37.5		
	32LVS5-□/20-65.5-e				110.5 - 45				
	32LVS5-□/22-65.5-e		7.5		26.5/23.7	254/295	128.5 - 53		
	32LVS5-□/24-67.5-e	147 - 60.5							
	50	10	50LVS10-□/1-6.75-e		0.75	200/220	3.2/3.1	25.0/28.5	100-280
50LVS10-□/2-61.5-e			1.5	5.9/5.4	41.0/47.6		28.5 - 13		
50LVS10-□/3-62.2-e			2.2	8.4/7.6	78.0/82.6		43 - 21		
50LVS10-□/4-63.0-e			3.0	11.5/10.8	115/135		57.5 - 28.5		
50LVS10-□/5-63.0-e				72 - 36.5					
50LVS10-□/6-64.0-e			4.0	14.3/12.8	132/151		86.5 - 44		
50LVS10-□/8-65.5-e			5.5	19.8/17.8	178/206		115.5 - 58.5		
50LVS10-□/9-65.5-e				130 - 66					
50LVS10-□/10-67.5-e			7.5	26.5/23.7	254/295		144.5 - 73		
50LVS10-□/12-67.5-e				173.5 - 88					
50LVS10-□/14-611-e		11	38.3/34.8	296/333	202.5 - 102.5				
50LVS10-□/16-611-e			231.5 - 117						
50LVS10-□/18-611-e		260.5 - 132							
15		50LVS15-□/1-61.5-e	1.5	200/230	5.9/5.4		41.0/47.6	160-450	18 - 9.5
			50LVS15-□/2-63.0-e		3.0		11.5/10.8		115/135
		50LVS15-□/3-64.0-e	4.0		14.3/12.8		132/151		55.5 - 34.5
		50LVS15-□/4-65.5-e	5.5		19.8/17.8		178/206		74 - 46
		50LVS15-□/5-67.5-e	7.5		26.5/23.7		254/295		92.5 - 57.5
		50LVS15-□/6-611-e	11		38.3/34.8		296/333		111 - 69
		50LVS15-□/7-611-e			130 - 81				
		50LVS15-□/8-611-e	15		53.0/49.0		397/447		148.5 - 92.5
		50LVS15-□/10-615-e			185.5 - 115.5				
		50LVS15-□/12-618-e	18.5		65.0/59.0		456/515		222.5 - 138.5
20		50LVS20-□/1-62.2-e	2.2	200/230	8.4/7.6		78.0/82.6	220-600	19 - 7
			50LVS20-□/2-64.0-e		4.0		14.3/12.8		132/151
		50LVS20-□/3-65.5-e	5.5		19.8/17.8		178/206		58.5 - 29.5
		50LVS20-□/4-67.5-e	7.5		26.5/23.7		254/295		78 - 39.5
		50LVS20-□/5-611-e	11		38.3/34.8		296/333		98 - 49
		50LVS20-□/6-611-e			117.5 - 59				
		50LVS20-□/7-615-e	15		53.0/49.0		397/447		137 - 69
		50LVS20-□/8-615-e			156.5 - 79				
		50LVS20-□/10-618-e	18.5		65.0/59.0		456/515		196 - 98.5

Note) The rated current in the table above is the recommended setting for the current value of the protective device.

●-7W type

60Hz

Bore diameter (mm)	Nominal flow rate (m³/h)	Type	Output (kW)	Rated voltage (V)	Rated current (A)	Starting current (A)	Discharge rate (L/min)	Total Head (m)
32	1	32LVS1-□/8-6.75-7W	0.75	200-230	3.2-3.1	25.0-28.5	10-50	67 - 35
		32LVS1-□/10-61.1-7W	1.1		4.4-4.1	32.5-37.0		84 - 44
		32LVS1-□/13-61.1-7W			1.5	5.9-5.4		41.0-47.6
		32LVS1-□/15-61.5-7W	2.2			8.4-7.6		78.0-82.6
		32LVS1-□/17-61.5-7W			3.0			
		32LVS1-□/21-62.2-7W	4.0			14.3-12.8		132-151
		32LVS1-□/23-62.2-7W			5.5			
		32LVS1-□/25-62.2-7W	7.5			26.5-23.7		254-295
	32LVS1-□/27-63.0-7W	10.5			32.5-37.0		32.5-37.0	
	3		32LVS3-□/5-6.75-7W			0.75		3.2-3.1
		32LVS3-□/6-61.1-7W	1.1		4.4-4.1	32.5-37.0	51.5 - 21	
		32LVS3-□/7-61.1-7W					1.5	5.9-5.4
		32LVS3-□/8-61.1-7W	2.2		8.4-7.6	78.0-82.6		
		32LVS3-□/10-61.5-7W					3.0	11.5-10.8
		32LVS3-□/11-61.5-7W	4.0		14.3-12.8	132-151		
		32LVS3-□/12-62.2-7W					5.5	19.8-17.8
		32LVS3-□/15-62.2-7W	7.5		26.5-23.7	254-295		
		32LVS3-□/17-62.2-7W					10.5	32.5-37.0
		32LVS3-□/19-63.0-7W	14.5		44.5-41.5	44.5-41.5		
		32LVS3-□/23-63.0-7W					20.5	61.5-58.5
		32LVS3-□/26-64.0-7W	28.5		84.5-81.5	84.5-81.5		
	5	32LVS5-□/3-61.1-7W					1.1	4.4-4.1
		32LVS5-□/4-61.1-7W	1.5		5.9-5.4	41.0-47.6		
		32LVS5-□/5-61.5-7W					2.2	8.4-7.6
		32LVS5-□/6-62.2-7W	3.0		11.5-10.8	115-135		
		32LVS5-□/7-62.2-7W					4.0	14.3-12.8
		32LVS5-□/8-62.2-7W	5.5		19.8-17.8	178-206		
		32LVS5-□/10-63.0-7W					7.5	26.5-23.7
		32LVS5-□/12-63.0-7W	10.5		32.5-37.0	32.5-37.0		
		32LVS5-□/14-64.0-7W					14.5	44.5-41.5
		32LVS5-□/16-64.0-7W	20.5		61.5-58.5	61.5-58.5		
		32LVS5-□/20-65.5-7W					28.5	84.5-81.5
32LVS5-□/22-65.5-7W		38.5	113.5-110.5	113.5-110.5	202.5 - 83			
32LVS5-□/24-67.5-7W	50.5				151.5-148.5	151.5-148.5	221 - 90.5	
50		10	50LVS10-□/1-6.75-7W	0.75			3.2-3.1	25.0-28.5
	50LVS10-□/2-61.5-7W		1.5	5.9-5.4	41.0-47.6	28.5 - 13		
	50LVS10-□/3-62.2-7W		2.2	8.4-7.6	78.0-82.6	43 - 21		
	50LVS10-□/4-63.0-7W		3.0	11.5-10.8	115-135	57.5 - 28.5		
	50LVS10-□/5-63.0-7W					4.0	14.3-12.8	132-151
	50LVS10-□/6-64.0-7W		5.5	19.8-17.8	178-206			
	50LVS10-□/8-65.5-7W					7.5	26.5-23.7	254-295
	50LVS10-□/9-65.5-7W		10.5	32.5-37.0	32.5-37.0			
	50LVS10-□/10-67.5-7W					14.5	44.5-41.5	44.5-41.5
	50LVS10-□/12-67.5-7W		20.5	61.5-58.5	61.5-58.5			
	15	50LVS15-□/1-61.5-7W				1.5	5.9-5.4	41.0-47.6
		50LVS15-□/2-63.0-7W	3.0	11.5-10.8	115-135	37 - 22		
		50LVS15-□/3-64.0-7W	4.0	14.3-12.8	132-151	55.5 - 34.5		
		50LVS15-□/4-65.5-7W	5.5	19.8-17.8	178-206	74 - 46		
		50LVS15-□/5-67.5-7W	7.5	26.5-23.7	254-295	92.5 - 57.5		
		20	50LVS20-□/1-62.2-7W	2.2	8.4-7.6	78.0-82.6	220-600	19 - 7
	50LVS20-□/2-64.0-7W		4.0	14.3-12.8	132-151	39 - 18		
	50LVS20-□/3-65.5-7W		5.5	19.8-17.8	178-206	58.5 - 29.5		
	50LVS20-□/4-67.5-7W		7.5	26.5-23.7	254-295	78 - 39.5		

Note 1) Contact us when your applications involve oil-based coolant liquid or special liquid (e.g. pure water, alkaline/acidic liquids).
 Note 2) The rated current is the recommended current setting for the protection device.

●-KS type

60Hz

Bore diameter (mm)	Nominal flow rate (m ³ /h)	Type	Output (kW)	Rated voltage (V)	Rated current (A)	Starting current (A)	Discharge rate (L/min)	Total Head (m)
32	1	32LVS1-□/8-6.75-KS	0.75	200-230	3.2-3.1	25.0-28.5	10-50	67 - 35
		32LVS1-□/10-61.1-KS	1.1		4.4-4.1	32.5-37.0		84 - 44
		32LVS1-□/13-61.1-KS			1.5	5.9-5.4		41.0-47.6
		32LVS1-□/15-61.5-KS	2.2			8.4-7.6		78.0-82.6
		32LVS1-□/17-61.5-KS			3.0			
		32LVS1-□/21-62.2-KS	4.0			14.3-12.8		132-151
		32LVS1-□/23-62.2-KS			5.5			
		32LVS1-□/25-62.2-KS	7.5			26.5-23.7		254-295
	32LVS1-□/27-63.0-KS	10.5			32.5-37.0		41.0-47.6	
	3		32LVS3-□/5-6.75-KS			0.75		3.2-3.1
		32LVS3-□/6-61.1-KS	1.1		4.4-4.1	32.5-37.0	51.5 - 21	
		32LVS3-□/7-61.1-KS					1.5	5.9-5.4
		32LVS3-□/8-61.1-KS	2.2		8.4-7.6	78.0-82.6		
		32LVS3-□/10-61.5-KS					3.0	11.5-10.8
		32LVS3-□/11-61.5-KS	4.0		14.3-12.8	132-151		
		32LVS3-□/12-62.2-KS					5.5	19.8-17.8
		32LVS3-□/15-62.2-KS	7.5		26.5-23.7	254-295		
		32LVS3-□/17-62.2-KS					10.5	32.5-37.0
		32LVS3-□/19-63.0-KS	14.5		44.4-4.1	32.5-37.0		
	32LVS3-□/23-63.0-KS	20.5					59.5-5.4	41.0-47.6
	32LVS3-□/26-64.0-KS		28.5		84.4-4.1	32.5-37.0		
	5	32LVS5-□/3-61.1-KS					1.1	4.4-4.1
		32LVS5-□/4-61.1-KS	1.5		5.9-5.4	41.0-47.6		
		32LVS5-□/5-61.5-KS					2.2	8.4-7.6
		32LVS5-□/6-62.2-KS	3.0		11.5-10.8	115-135		
		32LVS5-□/7-62.2-KS					4.0	14.3-12.8
		32LVS5-□/8-62.2-KS	5.5		19.8-17.8	178-206		
		32LVS5-□/10-63.0-KS					7.5	26.5-23.7
		32LVS5-□/12-63.0-KS	10.5		32.5-37.0	41.0-47.6		
		32LVS5-□/14-64.0-KS					14.5	44.4-4.1
		32LVS5-□/16-64.0-KS	20.5		59.5-5.4	41.0-47.6		
		32LVS5-□/20-65.5-KS					28.5	84.4-4.1
32LVS5-□/22-65.5-KS		38.5	114.4-4.1	41.0-47.6	202.5 - 83			
32LVS5-□/24-67.5-KS	50.5				154.4-4.1	41.0-47.6	221 - 90.5	
50		10	50LVS10-□/1-6.75-KS	0.75			3.2-3.1	25.0-28.5
	50LVS10-□/2-61.5-KS		1.5	5.9-5.4	41.0-47.6	28.5 - 13		
	50LVS10-□/3-62.2-KS		2.2	8.4-7.6	78.0-82.6	43 - 21		
	50LVS10-□/4-63.0-KS		3.0	11.5-10.8	115-135	57.5 - 28.5		
	50LVS10-□/5-63.0-KS					4.0	14.3-12.8	132-151
	50LVS10-□/6-64.0-KS		5.5	19.8-17.8	178-206			
	50LVS10-□/8-65.5-KS					7.5	26.5-23.7	254-295
	50LVS10-□/9-65.5-KS		10.5	32.5-37.0	41.0-47.6			
	50LVS10-□/10-67.5-KS					14.5	44.4-4.1	32.5-37.0
	50LVS10-□/12-67.5-KS	20.5	59.5-5.4	41.0-47.6	173.5 - 88			
	15				50LVS15-□/1-61.5-KS	1.5	5.9-5.4	41.0-47.6
		50LVS15-□/2-63.0-KS	3.0	11.5-10.8	115-135	37 - 22		
		50LVS15-□/3-64.0-KS	4.0	14.3-12.8	132-151	55.5 - 34.5		
		50LVS15-□/4-65.5-KS	5.5	19.8-17.8	178-206	74 - 46		
		50LVS15-□/5-67.5-KS	7.5	26.5-23.7	254-295	92.5 - 57.5		
		50LVS15-□/6-69.0-KS	10.5	32.5-37.0	41.0-47.6	111 - 70		
	20	50LVS20-□/1-62.2-KS	2.2	8.4-7.6	78.0-82.6	220-600	19 - 7	
		50LVS20-□/2-64.0-KS	4.0	14.3-12.8	132-151		39 - 18	
50LVS20-□/3-65.5-KS		5.5	19.8-17.8	178-206	58.5 - 29.5			
50LVS20-□/4-67.5-KS		7.5	26.5-23.7	254-295	78 - 39.5			
50LVS20-□/5-69.0-KS		10.5	32.5-37.0	41.0-47.6	98 - 50.5			

Note 1) Contact us when your applications involve oil-based coolant liquid or special liquid (e.g. pure water, alkaline/acidic liquids).

Note 2) The rated current is the recommended current setting for the protection device.

Assembly drawing

● Discharge diameter : 32mm

Fig.1

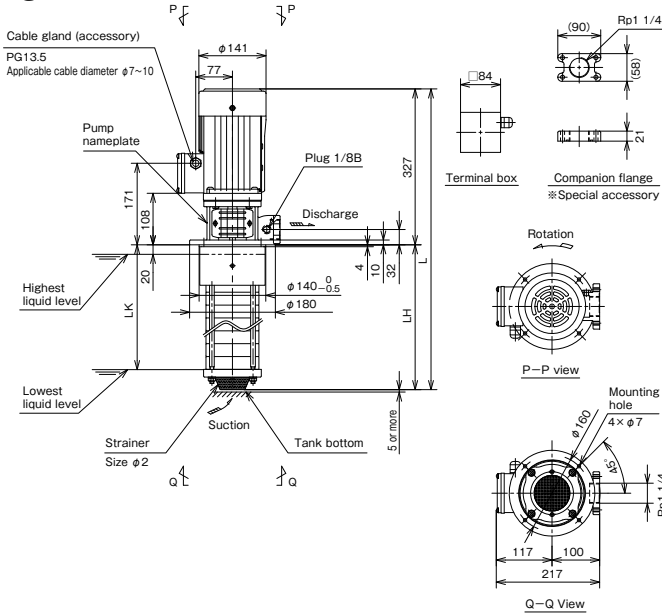

※Output 0.75kW

Fig.2

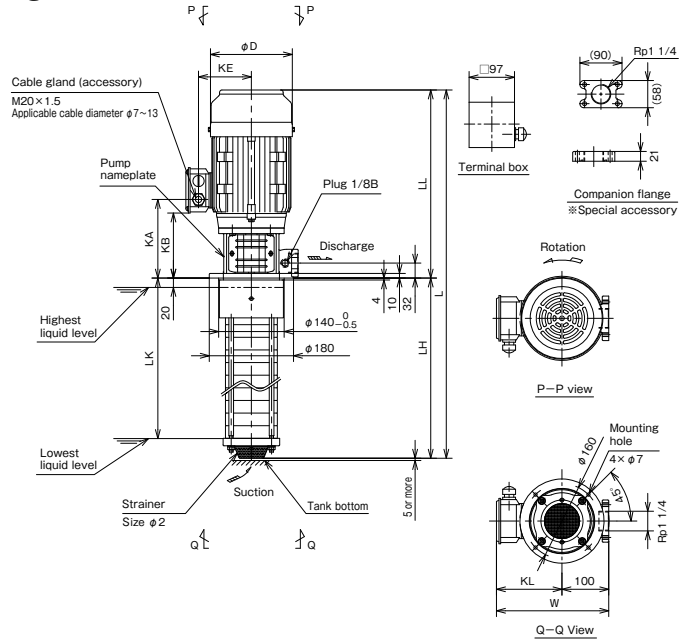

(Unit : mm)

Output kW	D	KA	KB	KE	KL	LL	W
1.1	175	147	118	113	140	381	240
1.5/2.2	175	168	139	113	140	402	240
3.0	196	179	149	125	152	435	252
4.0	219	183	154	134	161	442	—

Fig.3

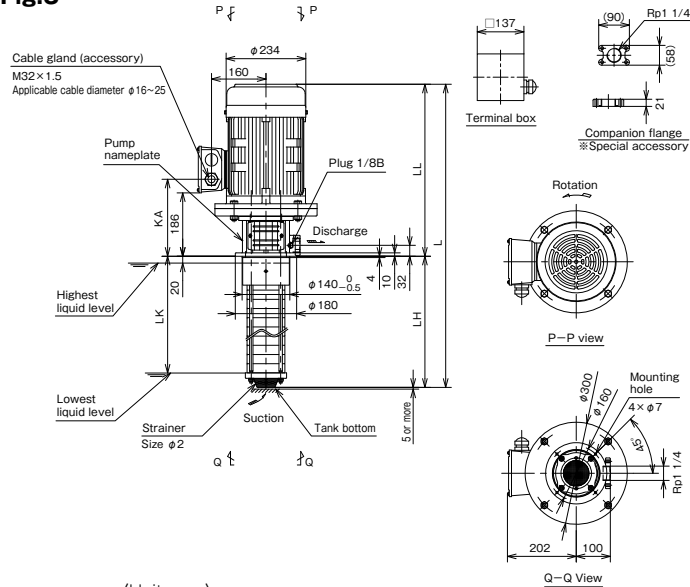

(Unit : mm)

Output kW	LL	KA
5.5	505	226
7.5	545	227

■ Dimensions

●Discharge diameter : 32mm, Nominal flow rate : 1m³/h

50Hz

(Unit : mm)

Type	Fig.	L	LH	LK	Approx. mass(kg)
32LVS1-13/13-5.75-e	1	676	349	307	21
32LVS1-15/13-5.75-e		712	385	343	22
32LVS1-17/13-5.75-e		748	421	379	22
32LVS1-21/13-5.75-e		820	493	451	23
32LVS1-25/13-5.75-e		892	565	523	24
32LVS1-15/15-5.75-e		712	385	343	22
32LVS1-17/15-5.75-e		748	421	379	22
32LVS1-21/15-5.75-e		820	493	451	23
32LVS1-25/15-5.75-e		892	565	523	24
32LVS1-17/17-51.1-e		802	421	379	27
32LVS1-21/17-51.1-e	874	493	451	27	
32LVS1-25/17-51.1-e	946	565	523	28	
32LVS1-30/17-51.1-e	1036	655	613	30	
32LVS1-21/21-51.1-e	874	493	451	28	
32LVS1-25/21-51.1-e	946	565	523	29	
32LVS1-30/21-51.1-e	1036	655	613	30	
32LVS1-33/21-51.1-e	1090	709	667	30	
32LVS1-23/23-51.1-e	910	529	487	28	
32LVS1-25/23-51.1-e	946	565	523	29	
32LVS1-30/23-51.1-e	1036	655	613	30	
32LVS1-33/23-51.1-e	1090	709	667	31	
32LVS1-36/23-51.1-e	1144	763	721	31	
32LVS1-27/27-51.5-e	1003	601	559	34	
32LVS1-33/27-51.5-e	1111	709	667	35	
32LVS1-36/27-51.5-e	1165	763	721	36	
32LVS1-30/30-51.5-e	1057	655	613	34	
32LVS1-33/30-51.5-e	1111	709	667	35	
32LVS1-36/30-51.5-e	1165	763	721	36	
32LVS1-33/33-52.2-e	1111	709	667	39	
32LVS1-36/33-52.2-e	1165	763	721	39	
32LVS1-36/36-52.2-e	1165	763	721	39	

60Hz

(Unit : mm)

Type	Fig.	L	LH	LK	Approx. mass(kg)
32LVS1-8/8-6.75-□	1	586	259	217	20
32LVS1-10/8-6.75-□		622	295	253	20
32LVS1-13/8-6.75-□		676	349	307	21
32LVS1-15/8-6.75-□		712	385	343	22
32LVS1-17/8-6.75-□		748	421	379	22
32LVS1-21/8-6.75-□		820	493	451	23
32LVS1-25/8-6.75-□		892	565	523	24
32LVS1-10/10-61.1-□		676	295	253	25
32LVS1-13/10-61.1-□		730	349	307	25
32LVS1-15/10-61.1-□		766	385	343	26
32LVS1-17/10-61.1-□	802	421	379	26	
32LVS1-21/10-61.1-□	874	493	451	27	
32LVS1-25/10-61.1-□	946	565	523	28	
32LVS1-13/13-61.1-□	730	349	307	25	
32LVS1-15/13-61.1-□	766	385	343	26	
32LVS1-17/13-61.1-□	802	421	379	26	
32LVS1-21/13-61.1-□	874	493	451	27	
32LVS1-25/13-61.1-□	946	565	523	28	
32LVS1-15/15-61.5-□	787	385	343	30	
32LVS1-17/15-61.5-□	823	421	379	31	
32LVS1-21/15-61.5-□	895	493	451	31	
32LVS1-25/15-61.5-□	967	565	523	32	
32LVS1-30/15-61.5-□	1057	655	613	34	
32LVS1-17/17-61.5-□	823	421	379	31	
32LVS1-21/17-61.5-□	895	493	451	32	
32LVS1-25/17-61.5-□	967	565	523	33	
32LVS1-30/17-61.5-□	1057	655	613	34	
32LVS1-33/17-61.5-□	1111	709	667	34	
32LVS1-21/21-62.2-□	895	493	451	35	
32LVS1-25/21-62.2-□	967	565	523	36	
32LVS1-30/21-62.2-□	1057	655	613	37	
32LVS1-33/21-62.2-□	1111	709	667	38	
32LVS1-36/21-62.2-□	1165	763	721	39	
32LVS1-23/23-62.2-□	931	529	487	36	
32LVS1-27/23-62.2-□	1003	601	559	37	
32LVS1-30/23-62.2-□	1057	655	613	37	
32LVS1-33/23-62.2-□	1111	709	667	38	
32LVS1-36/23-62.2-□	1165	763	721	39	
32LVS1-25/25-62.2-□	967	565	523	36	
32LVS1-27/25-62.2-□	1003	601	559	37	
32LVS1-30/25-62.2-□	1057	655	613	38	
32LVS1-33/25-62.2-□	1111	709	667	38	
32LVS1-36/25-62.2-□	1165	763	721	39	
32LVS1-27/27-63.0-□	1036	601	559	45	
32LVS1-30/27-63.0-□	1090	655	613	46	
32LVS1-33/27-63.0-□	1144	709	667	46	
32LVS1-36/27-63.0-□	1198	763	721	47	

Note 1) "□" in pump type can be any one of -e/-KS/ -7W.

●Discharge diameter : 32mm, Nominal flow rate : 3m³/h

50Hz

(Unit : mm)

Type	Fig.	L	LH	LK	Approx. mass(kg)
32LVS3-10/10-5.75-e	1	622	295	253	20
32LVS3-12/10-5.75-e		658	331	289	21
32LVS3-15/10-5.75-e		712	385	343	22
32LVS3-19/10-5.75-e		784	457	415	23
32LVS3-23/10-5.75-e		856	529	487	23
32LVS3-12/12-51.1-e	2	712	331	289	25
32LVS3-15/12-51.1-e		766	385	343	26
32LVS3-19/12-51.1-e		838	457	415	27
32LVS3-23/12-51.1-e		910	529	487	28
32LVS3-15/15-51.1-e		766	385	343	26
32LVS3-19/15-51.1-e		838	457	415	27
32LVS3-23/15-51.1-e		910	529	487	28
32LVS3-17/17-51.5-e		823	421	379	31
32LVS3-23/17-51.5-e		931	529	487	32
32LVS3-26/17-51.5-e		985	583	541	33
32LVS3-19/19-51.5-e		859	457	415	31
32LVS3-23/19-51.5-e		931	529	487	32
32LVS3-26/19-51.5-e		985	583	541	33
32LVS3-30/19-51.5-e		1057	655	613	34
32LVS3-25/25-52.2-e		967	565	523	36
32LVS3-30/25-52.2-e		1057	655	613	38
32LVS3-36/25-52.2-e		1165	763	721	39
32LVS3-30/30-53.0-e		1090	655	613	46
32LVS3-36/30-53.0-e		1198	763	721	47
32LVS3-36/36-53.0-e		1198	763	721	47

60Hz

(Unit : mm)

Type	Fig.	L	LH	LK	Approx. mass(kg)	
32LVS3-5/5-6.75-□	1	532	205	163	19	
32LVS3-7/5-6.75-□		568	241	199	19	
32LVS3-10/5-6.75-□		622	295	253	20	
32LVS3-12/5-6.75-□		658	331	289	21	
32LVS3-15/5-6.75-□		712	385	343	21	
32LVS3-19/5-6.75-□		784	457	415	22	
32LVS3-23/5-6.75-□		856	529	487	23	
32LVS3-6/6-61.1-□		2	604	223	181	23
32LVS3-10/6-61.1-□			676	295	253	24
32LVS3-12/6-61.1-□			712	331	289	25
32LVS3-15/6-61.1-□			766	385	343	26
32LVS3-19/6-61.1-□	838		457	415	26	
32LVS3-23/6-61.1-□	910		529	487	27	
32LVS3-7/7-61.1-□	622		241	199	24	
32LVS3-10/7-61.1-□	676		295	253	24	
32LVS3-12/7-61.1-□	712		331	289	25	
32LVS3-15/7-61.1-□	766		385	343	26	
32LVS3-19/7-61.1-□	838		457	415	26	
32LVS3-23/7-61.1-□	910		529	487	27	
32LVS3-8/8-61.1-□	640		259	217	24	
32LVS3-10/8-61.1-□	676		295	253	24	
32LVS3-12/8-61.1-□	712		331	289	25	
32LVS3-15/8-61.1-□	766		385	343	26	
32LVS3-19/8-61.1-□	838		457	415	27	
32LVS3-23/8-61.1-□	910		529	487	27	
32LVS3-10/10-61.5-□	697		295	253	29	
32LVS3-12/10-61.5-□	733		331	289	29	
32LVS3-15/10-61.5-□	787		385	343	30	
32LVS3-19/10-61.5-□	859		457	415	31	
32LVS3-23/10-61.5-□	931		529	487	32	
32LVS3-11/11-61.5-□	715		313	271	29	
32LVS3-15/11-61.5-□	787		385	343	30	
32LVS3-19/11-61.5-□	859		457	415	31	
32LVS3-23/11-61.5-□	931		529	487	32	
32LVS3-12/12-62.2-□	733		331	289	33	
32LVS3-15/12-62.2-□	787		385	343	33	
32LVS3-19/12-62.2-□	859		457	415	34	
32LVS3-23/12-62.2-□	931		529	487	35	
32LVS3-15/15-62.2-□	787		385	343	34	
32LVS3-19/15-62.2-□	859		457	415	34	
32LVS3-23/15-62.2-□	931	529	487	35		
32LVS3-26/15-62.2-□	985	583	541	36		
32LVS3-17/17-62.2-□	823	421	379	34		
32LVS3-23/17-62.2-□	931	529	487	35		
32LVS3-26/17-62.2-□	985	583	541	36		
32LVS3-30/17-62.2-□	1057	655	613	37		
32LVS3-19/19-63.0-□	892	457	415	43		
32LVS3-23/19-63.0-□	964	529	487	43		
32LVS3-26/19-63.0-□	1018	583	541	44		
32LVS3-30/19-63.0-□	1090	655	613	45		
32LVS3-36/19-63.0-□	1198	763	721	46		
32LVS3-23/23-63.0-□	964	529	487	44		
32LVS3-26/23-63.0-□	1018	583	541	44		
32LVS3-30/23-63.0-□	1090	655	613	45		
32LVS3-36/23-63.0-□	1198	763	721	47		
32LVS3-26/26-64.0-□	1025	583	541	50		
32LVS3-30/26-64.0-□	1097	655	613	51		
32LVS3-36/26-64.0-□	1205	763	721	52		

Note 1) "□" in pump type can be any one of -e/-KS/ -7W.

●Discharge diameter : 32mm, Nominal flow rate : 5m³/h

50Hz

(Unit : mm)

Type	Fig.	L	LH	LK	Approx. mass(kg)
32LVS5-5/5-5.75-e	1	577	250	208	20
32LVS5-7/5-5.75-e		631	304	262	20
32LVS5-10/5-5.75-e		712	385	343	21
32LVS5-14/5-5.75-e		820	493	451	22
32LVS5-16/5-5.75-e		874	547	505	23
32LVS5-20/5-5.75-e	2	982	655	613	24
32LVS5-8/8-51.1-e		652	331	289	25
32LVS5-10/8-51.1-e		766	385	343	25
32LVS5-14/8-51.1-e		874	493	451	27
32LVS5-16/8-51.1-e		928	547	505	27
32LVS5-20/8-51.1-e		1036	655	613	29
32LVS5-10/10-51.5-e		787	385	343	30
32LVS5-14/10-51.5-e		895	493	451	31
32LVS5-16/10-51.5-e		949	547	505	32
32LVS5-20/10-51.5-e		1057	655	613	33
32LVS5-14/14-52.2-e		895	493	451	35
32LVS5-16/14-52.2-e		949	547	505	35
32LVS5-20/14-52.2-e		1057	655	613	37
32LVS5-24/14-52.2-e		1165	763	721	38
32LVS5-16/16-52.2-e		949	547	505	35
32LVS5-20/16-52.2-e		1057	655	613	37
32LVS5-24/16-52.2-e		1165	763	721	38
32LVS5-29/16-52.2-e		1300	898	856	39
32LVS5-20/20-53.0-e		1090	655	613	45
32LVS5-24/20-53.0-e		1198	763	721	46
32LVS5-29/20-53.0-e	1333	898	856	48	
32LVS5-32/20-53.0-e	1414	979	937	49	
32LVS5-24/24-54.0-e	1205	763	721	52	
32LVS5-29/24-54.0-e	1340	898	856	53	
32LVS5-32/24-54.0-e	1421	979	937	54	
32LVS5-29/29-54.0-e	1340	898	856	53	
32LVS5-32/29-54.0-e	1421	979	937	54	
32LVS5-32/32-55.5-e	3	1484	979	937	82

60Hz

(Unit : mm)

Type	Fig.	L	LH	LK	Approx. mass(kg)
32LVS5-3/3-61.1-□	1	577	196	154	23
32LVS5-5/3-61.1-□		631	250	208	24
32LVS5-7/3-61.1-□		685	304	262	24
32LVS5-10/3-61.1-□		766	385	343	25
32LVS5-14/3-61.1-□		874	493	451	26
32LVS5-16/3-61.1-□		928	547	505	27
32LVS5-20/3-61.1-□		1036	655	613	28
32LVS5-4/4-61.1-□		604	223	181	23
32LVS5-6/4-61.1-□		658	277	235	24
32LVS5-8/4-61.1-□		712	331	289	24
32LVS5-10/4-61.1-□		766	385	343	25
32LVS5-14/4-61.1-□		874	493	451	27
32LVS5-16/4-61.1-□		928	547	505	28
32LVS5-20/4-61.1-□		1036	655	613	29
32LVS5-5/5-61.5-□		652	250	208	28
32LVS5-7/5-61.5-□		706	304	262	28
32LVS5-10/5-61.5-□		787	385	343	29
32LVS5-14/5-61.5-□		895	493	451	31
32LVS5-16/5-61.5-□		949	547	505	31
32LVS5-20/5-61.5-□		1057	655	613	33
32LVS5-6/6-62.2-□	679	277	235	32	
32LVS5-8/6-62.2-□	733	331	289	32	
32LVS5-10/6-62.2-□	787	385	343	33	
32LVS5-14/6-62.2-□	895	493	451	34	
32LVS5-16/6-62.2-□	949	547	505	35	
32LVS5-20/6-62.2-□	1057	655	613	36	
32LVS5-7/7-62.2-□	706	304	262	32	
32LVS5-10/7-62.2-□	787	385	343	33	
32LVS5-14/7-62.2-□	895	493	451	34	
32LVS5-16/7-62.2-□	949	547	505	35	
32LVS5-20/7-62.2-□	1057	655	613	36	
32LVS5-8/8-62.2-□	733	331	289	32	
32LVS5-10/8-62.2-□	787	385	343	33	
32LVS5-14/8-62.2-□	895	493	451	34	
32LVS5-16/8-62.2-□	949	547	505	35	
32LVS5-20/8-62.2-□	1057	655	613	36	
32LVS5-10/10-63.0-□	820	385	343	41	
32LVS5-14/10-63.0-□	928	493	451	42	
32LVS5-16/10-63.0-□	982	547	505	43	
32LVS5-20/10-63.0-□	1090	655	613	44	
32LVS5-12/12-63.0-□	874	439	397	42	
32LVS5-14/12-63.0-□	928	493	451	42	
32LVS5-16/12-63.0-□	982	547	505	43	
32LVS5-20/12-63.0-□	1090	655	613	44	
32LVS5-24/12-63.0-□	1198	763	721	45	
32LVS5-14/14-64.0-□	935	493	451	48	
32LVS5-16/14-64.0-□	989	547	505	49	
32LVS5-20/14-64.0-□	1097	655	613	50	
32LVS5-24/14-64.0-□	1205	763	721	51	
32LVS5-29/14-64.0-□	1340	898	856	53	
32LVS5-16/16-64.0-□	989	547	505	49	
32LVS5-20/16-64.0-□	1097	655	613	50	
32LVS5-24/16-64.0-□	1205	763	721	51	
32LVS5-29/16-64.0-□	1340	898	856	53	
32LVS5-32/16-64.0-□	1421	979	937	54	
32LVS5-20/20-65.5-□	1160	655	613	78	
32LVS5-24/20-65.5-□	1268	763	721	79	
32LVS5-29/20-65.5-□	1403	898	856	80	
32LVS5-32/20-65.5-□	1484	979	937	81	
32LVS5-22/22-65.5-□	1214	709	667	78	
32LVS5-24/22-65.5-□	1268	763	721	79	
32LVS5-29/22-65.5-□	1403	898	856	80	
32LVS5-32/22-65.5-□	1484	979	937	81	
32LVS5-24/24-67.5-□	1308	763	721	86	
32LVS5-29/24-67.5-□	1443	898	856	87	
32LVS5-32/24-67.5-□	1524	979	937	88	

Note 1) "□" in pump type can be any one of -e/-KS/ -7W.

Assembly drawing

● Discharge diameter : 50mm

Fig.1

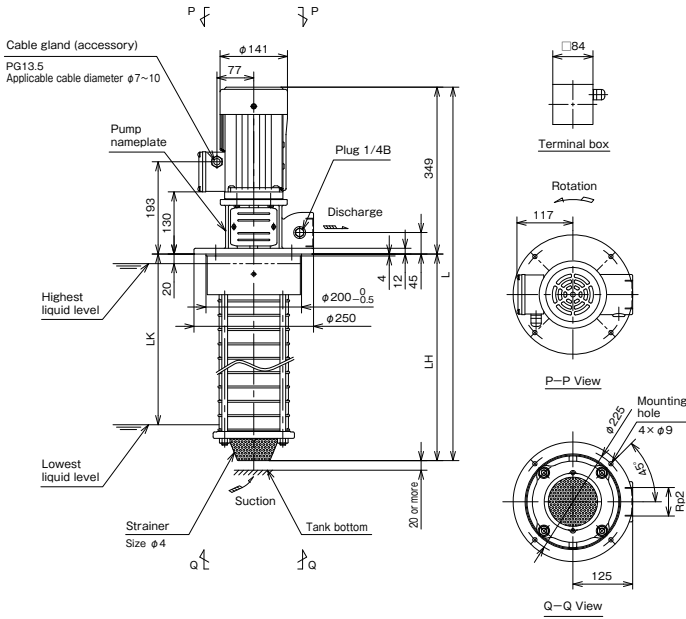

※Output 0.75kW

Fig.2

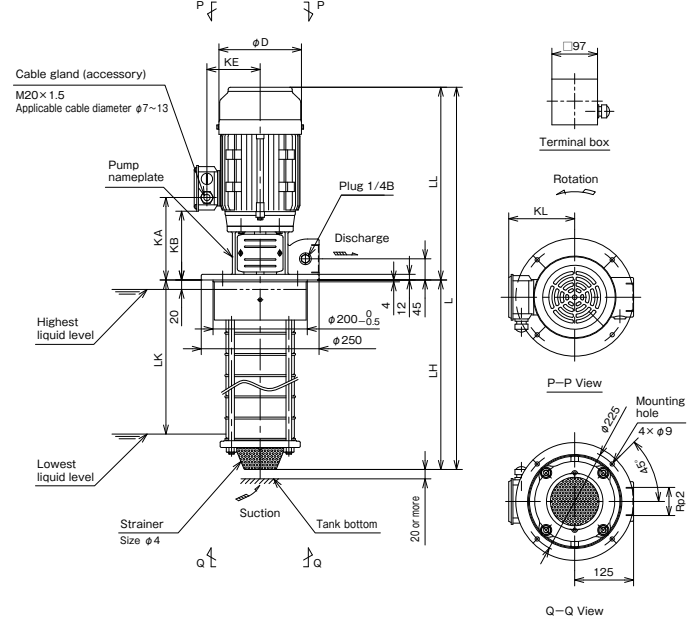

(Unit : mm)

Output kW	D	KA	KB	KE	KL	LL
1.1	175	169	140	113	140	403
1.5/2.2	175	175	146	113	140	409
3.0	196	186	156	125	152	442
4.0	219	190	161	134	161	449

Fig.3

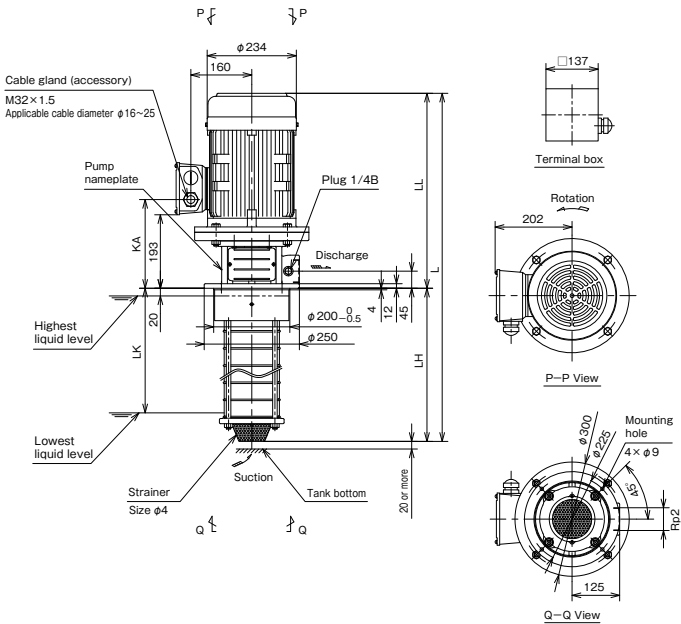

(Unit : mm)

Output kW	LL	KA
5.5	512	233
7.5	552	234

Fig.4

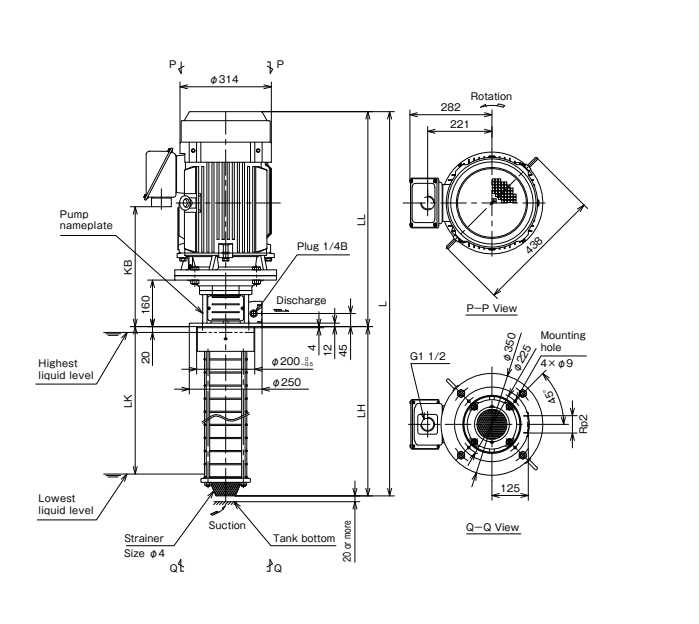

(Unit : mm)

Output kW	KB	LL
11/15	382	689
18.5	412	719

■ Dimensions

●Discharge diameter :50mm, Nominal flow rate : 10m³/h

50Hz

(Unit : mm)

Type	Fig.	L	LH	LK	Approx. mass(kg)	
50LVS10-5/2-5.75-e	1	631	282	207	28	
50LVS10-6/2-5.75-e		661	312	237	28	
50LVS10-8/2-5.75-e		721	372	297	30	
50LVS10-10/2-5.75-e		781	432	357	31	
50LVS10-12/2-5.75-e		841	492	417	32	
50LVS10-14/2-5.75-e		901	552	477	34	
50LVS10-16/2-5.75-e		961	612	537	35	
50LVS10-18/2-5.75-e		1021	672	597	36	
50LVS10-20/2-5.75-e		1081	732	657	38	
50LVS10-22/2-5.75-e		1141	792	717	39	
50LVS10-5/3-51.1-e		2	685	282	207	32
50LVS10-6/3-51.1-e			715	312	237	33
50LVS10-8/3-51.1-e	775		372	297	34	
50LVS10-10/3-51.1-e	835		432	357	35	
50LVS10-12/3-51.1-e	895		492	417	37	
50LVS10-14/3-51.1-e	955		552	477	38	
50LVS10-16/3-51.1-e	1015		612	537	39	
50LVS10-18/3-51.1-e	1075		672	597	40	
50LVS10-20/3-51.1-e	1135		732	657	42	
50LVS10-22/3-51.1-e	1195		792	717	43	
50LVS10-5/4-51.5-e	691		282	207	36	
50LVS10-6/4-51.5-e	721		312	237	36	
50LVS10-8/4-51.5-e	781		372	297	38	
50LVS10-10/4-51.5-e	841		432	357	39	
50LVS10-12/4-51.5-e	901		492	417	40	
50LVS10-14/4-51.5-e	961		552	477	42	
50LVS10-16/4-51.5-e	1021		612	537	43	
50LVS10-18/4-51.5-e	1081		672	597	44	
50LVS10-20/4-51.5-e	1141		732	657	46	
50LVS10-22/4-51.5-e	1201		792	717	47	
50LVS10-5/5-52.2-e	2		691	282	207	39
50LVS10-6/5-52.2-e			721	312	237	40
50LVS10-8/5-52.2-e			781	372	297	41
50LVS10-10/5-52.2-e			841	432	357	43
50LVS10-12/5-52.2-e			901	492	417	44
50LVS10-14/5-52.2-e			961	552	477	45
50LVS10-16/5-52.2-e			1021	612	537	47
50LVS10-18/5-52.2-e			1081	672	597	48
50LVS10-20/5-52.2-e			1141	732	657	49
50LVS10-22/5-52.2-e			1201	792	717	51
50LVS10-6/6-52.2-e			721	312	237	40
50LVS10-8/6-52.2-e			781	372	297	41
50LVS10-10/6-52.2-e		841	432	357	43	
50LVS10-12/6-52.2-e		901	492	417	44	
50LVS10-14/6-52.2-e		961	552	477	45	
50LVS10-16/6-52.2-e		1021	612	537	47	
50LVS10-18/6-52.2-e		1081	672	597	48	
50LVS10-20/6-52.2-e		1141	732	657	49	
50LVS10-22/6-52.2-e		1201	792	717	51	

(Unit : mm)

Type	Fig.	L	LH	LK	Approx. mass(kg)	
50LVS10-8/8-53.0-e	2	814	372	297	51	
50LVS10-10/8-53.0-e		874	432	357	52	
50LVS10-12/8-53.0-e		934	492	417	53	
50LVS10-14/8-53.0-e		994	552	477	55	
50LVS10-16/8-53.0-e		1054	612	537	56	
50LVS10-18/8-53.0-e		1114	672	597	57	
50LVS10-20/8-53.0-e		1174	732	657	59	
50LVS10-22/8-53.0-e		1234	792	717	60	
50LVS10-10/10-54.0-e		2	881	432	357	58
50LVS10-12/10-54.0-e			941	492	417	59
50LVS10-14/10-54.0-e			1001	552	477	60
50LVS10-16/10-54.0-e			1061	612	537	62
50LVS10-18/10-54.0-e			1121	672	597	63
50LVS10-20/10-54.0-e			1181	732	657	64
50LVS10-22/10-54.0-e			1241	792	717	66
50LVS10-12/12-54.0-e			941	492	417	59
50LVS10-14/12-54.0-e			1001	552	477	60
50LVS10-16/12-54.0-e			1061	612	537	62
50LVS10-18/12-54.0-e		1121	672	597	63	
50LVS10-20/12-54.0-e		1181	732	657	64	
50LVS10-22/12-54.0-e		1241	792	717	66	
50LVS10-14/14-55.5-e		3	1064	552	477	88
50LVS10-16/14-55.5-e	1124		612	537	89	
50LVS10-18/14-55.5-e	1184		672	597	91	
50LVS10-20/14-55.5-e	1244		732	657	92	
50LVS10-22/14-55.5-e	1304		792	717	93	
50LVS10-16/16-55.5-e	1124		612	537	90	
50LVS10-18/16-55.5-e	1184		672	597	91	
50LVS10-20/16-55.5-e	1244		732	657	92	
50LVS10-22/16-55.5-e	1304		792	717	93	
50LVS10-18/18-57.5-e	1224		672	597	98	
50LVS10-20/18-57.5-e	1284		732	657	99	
50LVS10-22/18-57.5-e	1344		792	717	100	
50LVS10-20/20-57.5-e	1284		732	657	99	
50LVS10-22/20-57.5-e	1344		792	717	100	
50LVS10-22/22-57.5-e	1344	792	717	101		

●Discharge diameter : 50mm, Nominal flow rate : 10m³/h

60Hz

(Unit : mm)

Type	Fig.	L	LH	LK	Approx. mass(kg)
50LVS10-5/1-6.75-□	1	631	282	207	28
50LVS10-6/1-6.75-□		661	312	237	28
50LVS10-8/1-6.75-□		721	372	297	30
50LVS10-10/1-6.75-□		781	432	357	31
50LVS10-12/1-6.75-□		841	492	417	32
50LVS10-5/2-61.5-□	2	691	282	207	36
50LVS10-6/2-61.5-□		721	312	237	36
50LVS10-8/2-61.5-□		781	372	297	38
50LVS10-10/2-61.5-□		841	432	357	39
50LVS10-12/2-61.5-□		901	492	417	40
50LVS10-14/2-61.5-□		961	552	477	42
50LVS10-16/2-61.5-□		1021	612	537	43
50LVS10-18/2-61.5-□		1081	672	597	44
50LVS10-20/2-61.5-□		1141	732	657	46
50LVS10-22/2-61.5-□		1201	792	717	47
50LVS10-5/3-62.2-□		691	282	207	39
50LVS10-6/3-62.2-□		721	312	237	40
50LVS10-8/3-62.2-□		781	372	297	41
50LVS10-10/3-62.2-□		841	432	357	42
50LVS10-12/3-62.2-□		901	492	417	44
50LVS10-14/3-62.2-□		961	552	477	45
50LVS10-16/3-62.2-□		1021	612	537	46
50LVS10-18/3-62.2-□		1081	672	597	48
50LVS10-20/3-62.2-□		1141	732	657	49
50LVS10-22/3-62.2-□		1201	792	717	50
50LVS10-5/4-63.0-□		724	282	207	48
50LVS10-6/4-63.0-□		754	312	237	49
50LVS10-8/4-63.0-□	814	372	297	50	
50LVS10-10/4-63.0-□	874	432	357	52	
50LVS10-12/4-63.0-□	934	492	417	53	
50LVS10-14/4-63.0-□	994	552	477	54	
50LVS10-16/4-63.0-□	1054	612	537	56	
50LVS10-18/4-63.0-□	1114	672	597	57	
50LVS10-20/4-63.0-□	1174	732	657	58	
50LVS10-22/4-63.0-□	1234	792	717	60	
50LVS10-5/5-63.0-□	724	282	207	48	
50LVS10-6/5-63.0-□	754	312	237	49	
50LVS10-8/5-63.0-□	814	372	297	50	
50LVS10-10/5-63.0-□	874	432	357	52	
50LVS10-12/5-63.0-□	934	492	417	53	
50LVS10-14/5-63.0-□	994	552	477	54	
50LVS10-16/5-63.0-□	1054	612	537	56	
50LVS10-18/5-63.0-□	1114	672	597	57	
50LVS10-20/5-63.0-□	1174	732	657	58	
50LVS10-22/5-63.0-□	1234	792	717	60	
50LVS10-6/6-64.0-□	761	312	237	55	
50LVS10-8/6-64.0-□	821	372	297	56	
50LVS10-10/6-64.0-□	881	432	357	57	
50LVS10-12/6-64.0-□	941	492	417	59	
50LVS10-14/6-64.0-□	1001	552	477	60	
50LVS10-16/6-64.0-□	1061	612	537	61	
50LVS10-18/6-64.0-□	1121	672	597	63	
50LVS10-20/6-64.0-□	1181	732	657	64	
50LVS10-22/6-64.0-□	1241	792	717	65	

Note 1) "□" in pump type can be any one of -e/-KS/ -7W.

(Unit : mm)

Type	Fig.	L	LH	LK	Approx. mass(kg)
50LVS10-8/8-65.5-□	3	884	372	297	83
50LVS10-10/8-65.5-□		944	432	357	85
50LVS10-12/8-65.5-□		1004	492	417	86
50LVS10-14/8-65.5-□		1064	552	477	87
50LVS10-16/8-65.5-□		1124	612	537	89
50LVS10-18/8-65.5-□		1184	672	597	90
50LVS10-20/8-65.5-□		1244	732	657	91
50LVS10-22/8-65.5-□		1304	792	717	93
50LVS10-9/9-65.5-□		914	402	327	84
50LVS10-12/9-65.5-□		1004	492	417	86
50LVS10-14/9-65.5-□		1064	552	477	88
50LVS10-16/9-65.5-□		1124	612	537	89
50LVS10-18/9-65.5-□		1184	672	597	90
50LVS10-20/9-65.5-□		1244	732	657	91
50LVS10-22/9-65.5-□		1304	792	717	93
50LVS10-10/10-67.5-□		984	432	357	92
50LVS10-12/10-67.5-□		1044	492	417	93
50LVS10-14/10-67.5-□		1104	552	477	94
50LVS10-16/10-67.5-□		1164	612	537	96
50LVS10-18/10-67.5-□		1224	672	597	97
50LVS10-20/10-67.5-□		1284	732	657	98
50LVS10-22/10-67.5-□		1344	792	717	100
50LVS10-12/12-67.5-□	1044	492	417	93	
50LVS10-14/12-67.5-□	1104	552	477	94	
50LVS10-16/12-67.5-□	1164	612	537	96	
50LVS10-18/12-67.5-□	1224	672	597	97	
50LVS10-20/12-67.5-□	1284	732	657	98	
50LVS10-22/12-67.5-□	1344	792	717	100	
50LVS10-14/14-611-e	4	1241	552	477	169
50LVS10-16/14-611-e		1301	612	537	170
50LVS10-18/14-611-e		1361	672	597	172
50LVS10-20/14-611-e		1421	732	657	173
50LVS10-22/14-611-e		1481	792	717	174
50LVS10-16/16-611-e		1301	612	537	170
50LVS10-18/16-611-e		1361	672	597	172
50LVS10-20/16-611-e		1421	732	657	173
50LVS10-22/16-611-e		1481	792	717	174
50LVS10-18/18-611-e		1361	672	597	172
50LVS10-20/18-611-e		1421	732	657	173
50LVS10-22/18-611-e		1481	792	717	175

Note 1) "□" in pump type can be any one of -e/-KS/ -7W.

●Discharge diameter : 50mm, Nominal flow rate : 15m³/h

50Hz

(Unit : mm)

Type	Fig.	L	LH	LK	Approx. mass(kg)
50LVS15-3/1-51.1-e	2	670	267	192	31
50LVS15-4/1-51.1-e		715	312	237	32
50LVS15-5/1-51.1-e		760	357	282	33
50LVS15-6/1-51.1-e		805	402	327	34
50LVS15-7/1-51.1-e		850	447	372	35
50LVS15-8/1-51.1-e		895	492	417	36
50LVS15-3/2-52.2-e		676	267	192	39
50LVS15-4/2-52.2-e		721	312	237	39
50LVS15-5/2-52.2-e		766	357	282	40
50LVS15-6/2-52.2-e		811	402	327	41
50LVS15-7/2-52.2-e		856	447	372	42
50LVS15-8/2-52.2-e		901	492	417	43
50LVS15-10/2-52.2-e		991	582	507	44
50LVS15-12/2-52.2-e		1081	672	597	46
50LVS15-14/2-52.2-e		1171	762	687	48
50LVS15-3/3-53.0-e		709	267	192	48
50LVS15-4/3-53.0-e		754	312	237	48
50LVS15-5/3-53.0-e		799	357	282	49
50LVS15-6/3-53.0-e		844	402	327	50
50LVS15-7/3-53.0-e		889	447	372	51
50LVS15-8/3-53.0-e		934	492	417	52
50LVS15-10/3-53.0-e		1024	582	507	54
50LVS15-12/3-53.0-e		1114	672	597	55
50LVS15-14/3-53.0-e		1204	762	687	57
50LVS15-4/4-54.0-e		761	312	237	54
50LVS15-5/4-54.0-e		806	357	282	55
50LVS15-6/4-54.0-e		851	402	327	56
50LVS15-7/4-54.0-e		896	447	372	57
50LVS15-8/4-54.0-e		941	492	417	58
50LVS15-10/4-54.0-e		1031	582	507	59
50LVS15-12/4-54.0-e		1121	672	597	61
50LVS15-14/4-54.0-e		1211	762	687	63
50LVS15-17/4-54.0-e		1346	897	822	65
50LVS15-5/5-54.0-e		806	357	282	55
50LVS15-6/5-54.0-e		851	402	327	56
50LVS15-7/5-54.0-e		896	447	372	57
50LVS15-8/5-54.0-e		941	492	417	58
50LVS15-10/5-54.0-e		1031	582	507	59
50LVS15-12/5-54.0-e		1121	672	597	61
50LVS15-14/5-54.0-e		1211	762	687	63
50LVS15-17/5-54.0-e		1346	897	822	65
50LVS15-6/6-55.5-e		914	402	327	84
50LVS15-7/6-55.5-e		959	447	372	84
50LVS15-8/6-55.5-e		1004	492	417	85
50LVS15-10/6-55.5-e		1094	582	507	87
50LVS15-12/6-55.5-e		1184	672	597	89
50LVS15-14/6-55.5-e		1274	762	687	90
50LVS15-17/6-55.5-e		1409	897	822	93
50LVS15-7/7-55.5-e		959	447	372	85
50LVS15-8/7-55.5-e		1004	492	417	85
50LVS15-10/7-55.5-e	1094	582	507	87	
50LVS15-12/7-55.5-e	1184	672	597	89	
50LVS15-14/7-55.5-e	1274	762	687	90	
50LVS15-17/7-55.5-e	1409	897	822	93	
50LVS15-8/8-57.5-e	1044	492	417	92	
50LVS15-10/8-57.5-e	1134	582	507	94	
50LVS15-12/8-57.5-e	1224	672	597	96	
50LVS15-14/8-57.5-e	1314	762	687	97	
50LVS15-17/8-57.5-e	1449	897	822	100	
50LVS15-9/9-57.5-e	1089	537	462	93	
50LVS15-12/9-57.5-e	1224	672	597	96	
50LVS15-14/9-57.5-e	1314	762	687	97	
50LVS15-17/9-57.5-e	1449	897	822	100	
50LVS15-10/10-511-e	1271	582	507	169	
50LVS15-12/10-511-e	1361	672	597	170	
50LVS15-14/10-511-e	1451	762	687	172	
50LVS15-17/10-511-e	1586	897	822	174	
50LVS15-12/12-511-e	1361	672	597	171	
50LVS15-14/12-511-e	1451	762	687	172	
50LVS15-17/12-511-e	1586	897	822	175	
50LVS15-14/14-511-e	1451	762	687	173	
50LVS15-17/14-511-e	1586	897	822	175	
50LVS15-17/17-515-e	1586	897	822	187	

60Hz

(Unit : mm)

Type	Fig.	L	LH	LK	Approx. mass(kg)
50LVS15-3/1-61.5-□	2	676	267	192	35
50LVS15-4/1-61.5-□		721	312	237	36
50LVS15-5/1-61.5-□		766	357	282	37
50LVS15-6/1-61.5-□		811	402	327	38
50LVS15-7/1-61.5-□		856	447	372	38
50LVS15-8/1-61.5-□		901	492	417	39
50LVS15-10/1-61.5-□		991	582	507	41
50LVS15-3/2-63.0-□		709	267	192	48
50LVS15-4/2-63.0-□		754	312	237	48
50LVS15-5/2-63.0-□		799	357	282	49
50LVS15-6/2-63.0-□		844	402	327	50
50LVS15-7/2-63.0-□		889	447	372	51
50LVS15-8/2-63.0-□		934	492	417	52
50LVS15-10/2-63.0-□		1024	582	507	54
50LVS15-12/2-63.0-□		1114	672	597	55
50LVS15-14/2-63.0-□		1204	762	687	57
50LVS15-17/2-63.0-□		1339	897	822	60
50LVS15-3/3-64.0-□		716	267	192	53
50LVS15-4/3-64.0-□		761	312	237	54
50LVS15-5/3-64.0-□		806	357	282	55
50LVS15-6/3-64.0-□		851	402	327	56
50LVS15-7/3-64.0-□		896	447	372	56
50LVS15-8/3-64.0-□		941	492	417	57
50LVS15-10/3-64.0-□		1031	582	507	59
50LVS15-12/3-64.0-□		1121	672	597	61
50LVS15-14/3-64.0-□		1211	762	687	62
50LVS15-17/3-64.0-□		1346	897	822	65
50LVS15-4/4-65.5-□		824	312	237	81
50LVS15-5/4-65.5-□		869	357	282	82
50LVS15-6/4-65.5-□		914	402	327	83
50LVS15-7/4-65.5-□		959	447	372	84
50LVS15-8/4-65.5-□		1004	492	417	85
50LVS15-10/4-65.5-□		1094	582	507	87
50LVS15-12/4-65.5-□		1184	672	597	88
50LVS15-14/4-65.5-□		1274	762	687	90
50LVS15-17/4-65.5-□		1409	897	822	92
50LVS15-5/5-67.5-□		909	357	282	89
50LVS15-6/5-67.5-□		954	402	327	90
50LVS15-7/5-67.5-□		999	447	372	91
50LVS15-8/5-67.5-□		1044	492	417	92
50LVS15-10/5-67.5-□		1134	582	507	93
50LVS15-12/5-67.5-□		1224	672	597	95
50LVS15-14/5-67.5-□		1314	762	687	97
50LVS15-17/5-67.5-□		1449	897	822	99
50LVS15-6/6-611-e		1091	402	327	164
50LVS15-7/6-611-e		1136	447	372	165
50LVS15-8/6-611-e		1181	492	417	166
50LVS15-10/6-611-e		1271	582	507	168
50LVS15-12/6-611-e		1361	672	597	169
50LVS15-14/6-611-e		1451	762	687	171
50LVS15-17/6-611-e	1586	897	822	174	
50LVS15-7/7-611-e	1136	447	372	165	
50LVS15-8/7-611-e	1181	492	417	166	
50LVS15-10/7-611-e	1271	582	507	168	
50LVS15-12/7-611-e	1361	672	597	170	
50LVS15-14/7-611-e	1451	762	687	171	
50LVS15-17/7-611-e	1586	897	822	174	
50LVS15-8/8-611-e	1181	492	417	167	
50LVS15-10/8-611-e	1271	582	507	168	
50LVS15-12/8-611-e	1361	672	597	170	
50LVS15-14/8-611-e	1451	762	687	172	
50LVS15-17/8-611-e	1586	897	822	174	
50LVS15-10/10-615-e	1271	582	507	180	
50LVS15-12/10-615-e	1361	672	597	181	
50LVS15-14/10-615-e	1451	762	687	183	
50LVS15-17/10-615-e	1586	897	822	185	
50LVS15-12/12-618-e	1391	672	597	198	
50LVS15-14/12-618-e	1481	762	687	199	
50LVS15-17/12-618-e	1616	897	822	202	

Note 1) "□" in pump type can be any one of -e/-KS/-7W.

●Discharge diameter : 50mm, Nominal flow rate : 20m³/h

50Hz

(Unit : mm)

Type	Fig.	L	LH	LK	Approx. mass(kg)
50LVS20-3/1-51.1-e	2	670	267	192	31
50LVS20-4/1-51.1-e		715	312	237	32
50LVS20-5/1-51.1-e		760	357	282	33
50LVS20-6/1-51.1-e		805	402	327	34
50LVS20-3/2-52.2-e		676	267	192	39
50LVS20-4/2-52.2-e		721	312	237	39
50LVS20-5/2-52.2-e		766	357	282	40
50LVS20-6/2-52.2-e		811	402	327	41
50LVS20-7/2-52.2-e		856	447	372	42
50LVS20-8/2-52.2-e		901	492	417	43
50LVS20-10/2-52.2-e		991	582	507	44
50LVS20-12/2-52.2-e		1081	672	597	46
50LVS20-3/3-54.0-e		716	267	192	53
50LVS20-4/3-54.0-e		761	312	237	54
50LVS20-5/3-54.0-e		806	357	282	55
50LVS20-6/3-54.0-e		851	402	327	56
50LVS20-7/3-54.0-e		896	447	372	56
50LVS20-8/3-54.0-e		941	492	417	57
50LVS20-10/3-54.0-e		1031	582	507	59
50LVS20-12/3-54.0-e		1121	672	597	61
50LVS20-14/3-54.0-e	1211	762	687	62	
50LVS20-17/3-54.0-e	1346	897	822	65	
50LVS20-4/4-55.5-e	3	824	312	237	81
50LVS20-5/4-55.5-e		869	357	282	82
50LVS20-6/4-55.5-e		914	402	327	83
50LVS20-7/4-55.5-e		959	447	372	84
50LVS20-8/4-55.5-e		1004	492	417	85
50LVS20-10/4-55.5-e		1094	582	507	87
50LVS20-12/4-55.5-e		1184	672	597	88
50LVS20-14/4-55.5-e		1274	762	687	90
50LVS20-17/4-55.5-e		1409	897	822	92
50LVS20-5/5-55.5-e		869	357	282	83
50LVS20-6/5-55.5-e		914	402	327	83
50LVS20-7/5-55.5-e		959	447	372	84
50LVS20-8/5-55.5-e		1004	492	417	85
50LVS20-10/5-55.5-e		1094	582	507	87
50LVS20-12/5-55.5-e		1184	672	597	88
50LVS20-14/5-55.5-e		1274	762	687	90
50LVS20-17/5-55.5-e		1409	897	822	92
50LVS20-6/6-57.5-e		954	402	327	90
50LVS20-7/6-57.5-e		999	447	372	91
50LVS20-8/6-57.5-e		1044	492	417	92
50LVS20-10/6-57.5-e	1134	582	507	94	
50LVS20-12/6-57.5-e	1224	672	597	95	
50LVS20-14/6-57.5-e	1314	762	687	97	
50LVS20-17/6-57.5-e	1449	897	822	99	
50LVS20-7/7-57.5-e	999	447	372	91	
50LVS20-8/7-57.5-e	1044	492	417	92	
50LVS20-10/7-57.5-e	1134	582	507	94	
50LVS20-12/7-57.5-e	1224	672	597	95	
50LVS20-14/7-57.5-e	1314	762	687	97	
50LVS20-17/7-57.5-e	1449	897	822	100	
50LVS20-8/8-511-e	4	1181	492	417	167
50LVS20-10/8-511-e		1271	582	507	168
50LVS20-12/8-511-e		1361	672	597	170
50LVS20-14/8-511-e		1451	762	687	172
50LVS20-17/8-511-e		1586	897	822	174
50LVS20-10/10-511-e		1271	582	507	168
50LVS20-12/10-511-e		1361	672	597	170
50LVS20-14/10-511-e		1451	762	687	172
50LVS20-17/10-511-e		1586	897	822	174
50LVS20-12/12-515-e		1361	672	597	182
50LVS20-14/12-515-e		1451	762	687	183
50LVS20-17/12-515-e		1586	897	822	186
50LVS20-14/14-515-e		1451	762	687	183
50LVS20-17/14-515-e		1586	897	822	186
50LVS20-17/17-518-e		1616	897	822	203

60Hz

(Unit : mm)

Type	Fig.	L	LH	LK	Approx. mass(kg)	
50LVS20-3/1-62.2-□	2	676	267	192	39	
50LVS20-4/1-62.2-□		721	312	237	39	
50LVS20-5/1-62.2-□		766	357	282	40	
50LVS20-6/1-62.2-□		811	402	327	41	
50LVS20-7/1-62.2-□		856	447	372	42	
50LVS20-3/2-64.0-□		716	267	192	53	
50LVS20-4/2-64.0-□		761	312	237	54	
50LVS20-5/2-64.0-□		806	357	282	55	
50LVS20-6/2-64.0-□		851	402	327	56	
50LVS20-7/2-64.0-□		896	447	372	56	
50LVS20-8/2-64.0-□		941	492	417	57	
50LVS20-10/2-64.0-□		1031	582	507	59	
50LVS20-12/2-64.0-□		1121	672	597	61	
50LVS20-3/3-65.5-□		3	779	267	192	80
50LVS20-4/3-65.5-□			824	312	237	81
50LVS20-5/3-65.5-□			869	357	282	82
50LVS20-6/3-65.5-□			914	402	327	83
50LVS20-7/3-65.5-□			959	447	372	84
50LVS20-8/3-65.5-□			1004	492	417	85
50LVS20-10/3-65.5-□			1094	582	507	86
50LVS20-12/3-65.5-□	1184		672	597	88	
50LVS20-14/3-65.5-□	1274		762	687	90	
50LVS20-17/3-65.5-□	1409		897	822	92	
50LVS20-4/4-67.5-□	864		312	237	88	
50LVS20-5/4-67.5-□	909		357	282	89	
50LVS20-6/4-67.5-□	954		402	327	90	
50LVS20-7/4-67.5-□	999		447	372	91	
50LVS20-8/4-67.5-□	1044		492	417	91	
50LVS20-10/4-67.5-□	1134		582	507	93	
50LVS20-12/4-67.5-□	1224		672	597	95	
50LVS20-14/4-67.5-□	1314		762	687	96	
50LVS20-17/4-67.5-□	1449		897	822	99	
50LVS20-5/5-611-e	4		1046	357	282	163
50LVS20-6/5-611-e		1091	402	327	164	
50LVS20-7/5-611-e		1136	447	372	165	
50LVS20-8/5-611-e		1181	492	417	166	
50LVS20-10/5-611-e		1271	582	507	168	
50LVS20-12/5-611-e		1361	672	597	169	
50LVS20-14/5-611-e		1451	762	687	171	
50LVS20-17/5-611-e		1586	897	822	173	
50LVS20-6/6-611-e		1091	402	327	164	
50LVS20-7/6-611-e		1136	447	372	165	
50LVS20-8/6-611-e		1181	492	417	166	
50LVS20-10/6-611-e		1271	582	507	168	
50LVS20-12/6-611-e		1361	672	597	169	
50LVS20-14/6-611-e		1451	762	687	171	
50LVS20-17/6-611-e		1586	897	822	173	
50LVS20-7/7-615-e		1136	447	372	176	
50LVS20-8/7-615-e		1181	492	417	177	
50LVS20-10/7-615-e		1271	582	507	179	
50LVS20-12/7-615-e		1361	672	597	181	
50LVS20-14/7-615-e		1451	762	687	182	
50LVS20-17/7-615-e	1586	897	822	185		
50LVS20-8/8-615-e	1181	492	417	177		
50LVS20-10/8-615-e	1271	582	507	179		
50LVS20-12/8-615-e	1361	672	597	181		
50LVS20-14/8-615-e	1451	762	687	182		
50LVS20-17/8-615-e	1586	897	822	185		
50LVS20-10/10-618-e	1301	582	507	196		
50LVS20-12/10-618-e	1391	672	597	197		
50LVS20-14/10-618-e	1481	762	687	199		
50LVS20-17/10-618-e	1616	897	822	201		

Note 1) "□" in pump type can be any one of -e/-KS/-7W.

■ Detailed drawing of the terminal box

■ Assembly drawing (-e/-KS type)

● Output 0.75kW

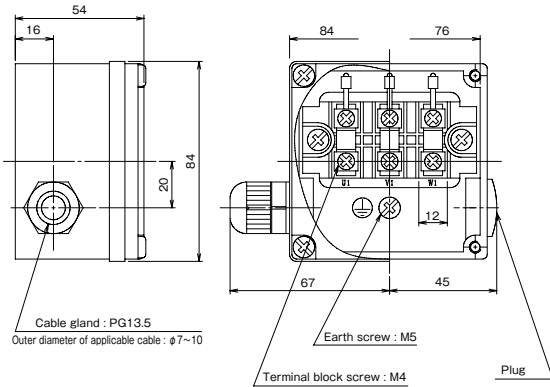

■ Connection diagram

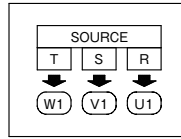

● Output 1.1-4.0 kW

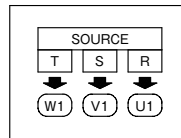
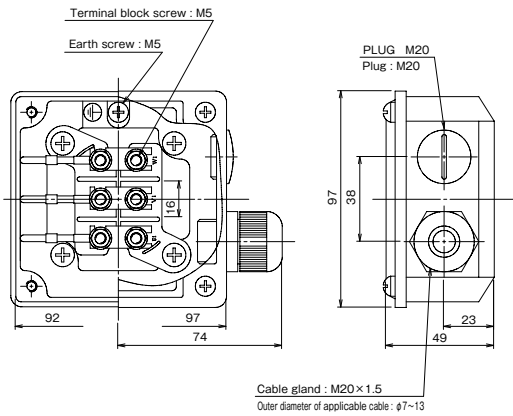

● Output 5.5, 7.5 kW

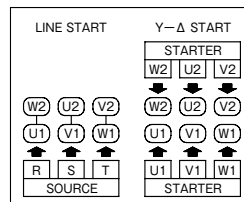
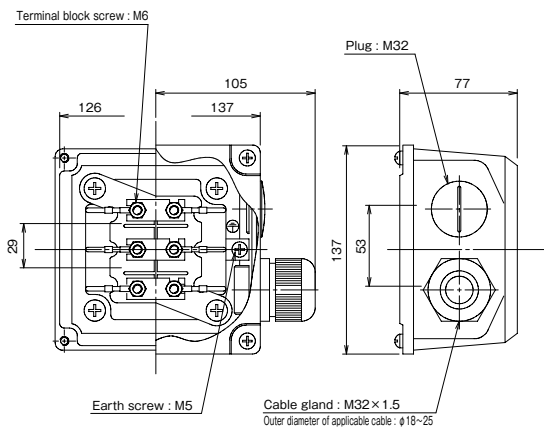

● Output 11-18.5 kW (-e type)

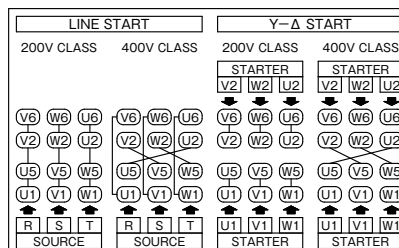
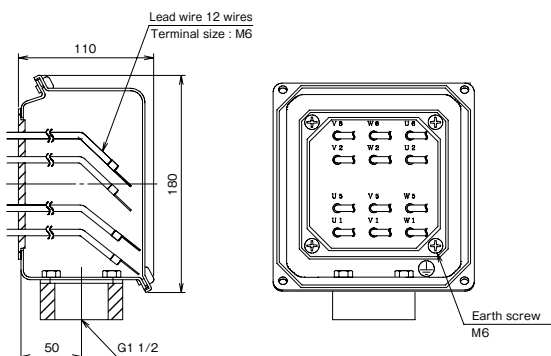

Assembly drawing (-7W type)

Output 0.75kW

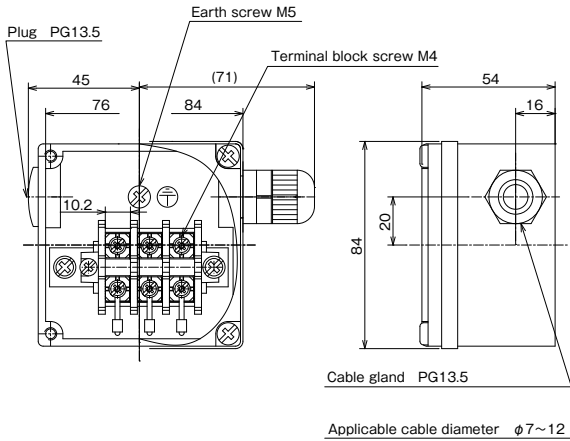

Connection diagram

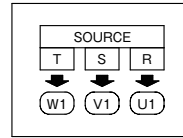

Output 1.1-4.0kW

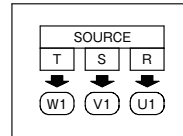
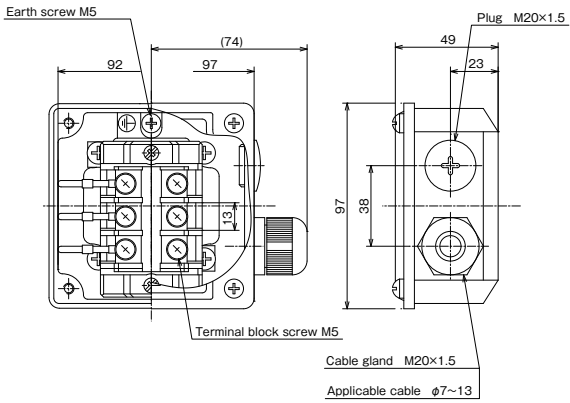

Output 5.5kW, 7.5kW

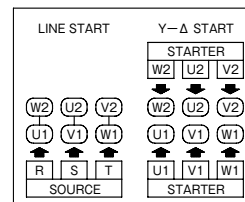
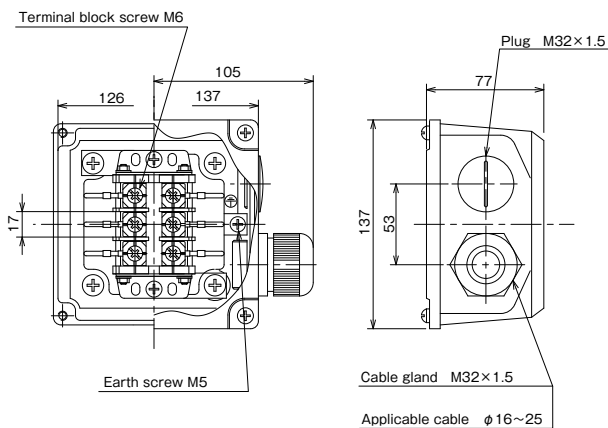

Sectional drawing

●32LVS-e

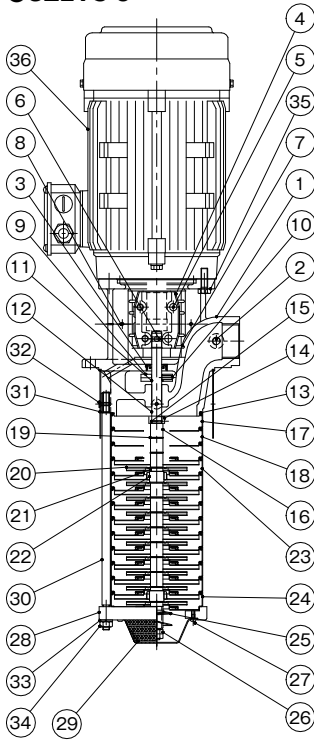

No.	Part name	Material
1	Discharge casing	FC200
2	Plug	SWCH
3	Oil seal	NBR
4	Coupling	FCC205
5	Hexagon socket head bolt	SCM435
6	Shaft pin	SUS316
7	Coupling cover	SUS304
8	Cross-recessed pan head screw	SUS304
9	Oil thrower	SUS304
10	Set screw	SCM435
11	O-ring	FKM
12	Main shaft	SUS420J2
13	Gasket	—
14	Shaft bushing	SUS304
15	Shaft ring	SUS316
16	Sleeve	SUS304
17	Intermediate casing (Final stage)	SUS304
18	Intermediate casing	SUS304
19	Shim	SUS304
20	Impeller	SUS304
21	Baffle	SUS304
22	Bearings	SiC
23	Bearing casing	SUS304+SiC
24	Intermediate casing (First stage)	SUS304
25	Screw	SUS304
26	Hardlock nut	SUS304
27	Cross-recessed pan head screw	SUS304
28	Suction casing	FC200
29	Strainer	SUS304
30	Through bolt	SUS304
31	Outer sleeve	SUS304
32	Cross-recessed flat head screw	SUS304
33	Spring washer	SUS304
34	Hexagon nut	SUS304
35	Hexagon bolt	SUS304
36	Motor	—

Note 1) The materials in the table above are equivalents.
Note 2) Structure and other details are subject to change without notice.

●50LVS-e

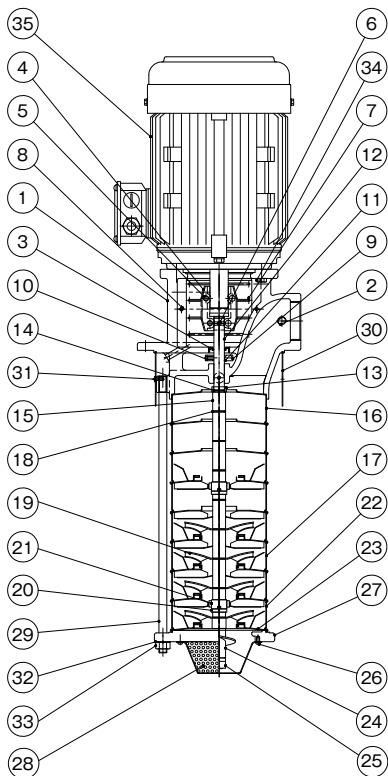

No.	Part name	Material
1	Discharge casing	FC200
2	Plug	SWCH
3	Oil seal	NBR
4	Coupling	FCC205
5	Hexagon socket head bolt	SCM435
6	Shaft pin	SUS316
7	Coupling cover	SUS304
8	Cross-recessed pan head screw	SUS304
9	Oil thrower	SUS304
10	Set screw	SCM435
11	O-ring	FKM
12	Main shaft	SUS420J2
13	Shaft bushing	SUS304
14	Shaft ring	SUS316
15	Sleeve	SUS304
16	Intermediate casing (Final stage)	SUS304
17	Intermediate casing	SUS304
18	Shim	SUS304
19	Impeller	SUS304
20	Baffle	SUS304
21	Bearings	SiC
22	Bearing casing	SUS304+SiC
23	Intermediate casing (First stage)	SUS304
24	Screw	SUS304
25	Hardlock nut	SUS304
26	Cross-recessed pan head screw	SUS304
27	Suction casing	FCD450
28	Strainer	SUS304
29	Through bolt	SUS304
30	Outer sleeve	SUS304
31	Cross-recessed flat head screw	SUS304
32	Plain washer	SUS304
33	Hexagon nut	SUS304
34	Hexagon bolt	SUS304
35	Motor	—

Note 1) The materials in the table above are equivalents.
Note 2) Structure and other details are subject to change without notice.

Features

- ① Non-seal (mechanical seal-less) structure is adopted.
- ② Stainless steel is used in the pump's main liquid contact part and SiC bearings with increased wear resistance are adopted.
- ③ Measures against air suction into the pump are taken when the fluid level lowers.
- ④ Energy saving by high efficiency impeller!
- ⑤ The lineup including the models complying with global standards by supporting efficiency and other regulations.

- Japan : Top Runner efficiency
- Europe : IE3 efficiency, CE marking(EU Directive)
RoHS Directive (2011/65/EU), 10 restricted substances
- USA : NEMA Premium efficiency (IE3 efficiency), UL standards (safety)
- Korea : Energy Efficiency Label and Standard Program (KC Standards, IE3)
- Canada : CSA standard (efficiency), CSA standard (safety)

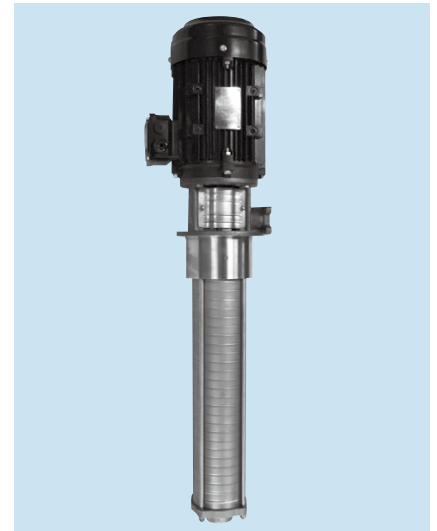

Please note that the paint color, etc. of the actual unit may partially differ from the photo.

Non-seal structure

TERAL's original "non-seal" structure allows coolant to flow from a narrow clearance without using a seal between the pump section and the motor section.

The advantages of a non-seal pump

- 1 No trouble such as coolant leaks.**
Helps cut down on running costs.
- 2 Prevents air entrainment.**
Reduces initial problems.
- 3 Not easily affected by a small quantity of liquid or shut-off operations.**
Enables a flexible operation system.

※What is non-seal structure?

This structure inwardly releases coolant by depressurizing through a narrow clearance without the use of a mechanical seal.

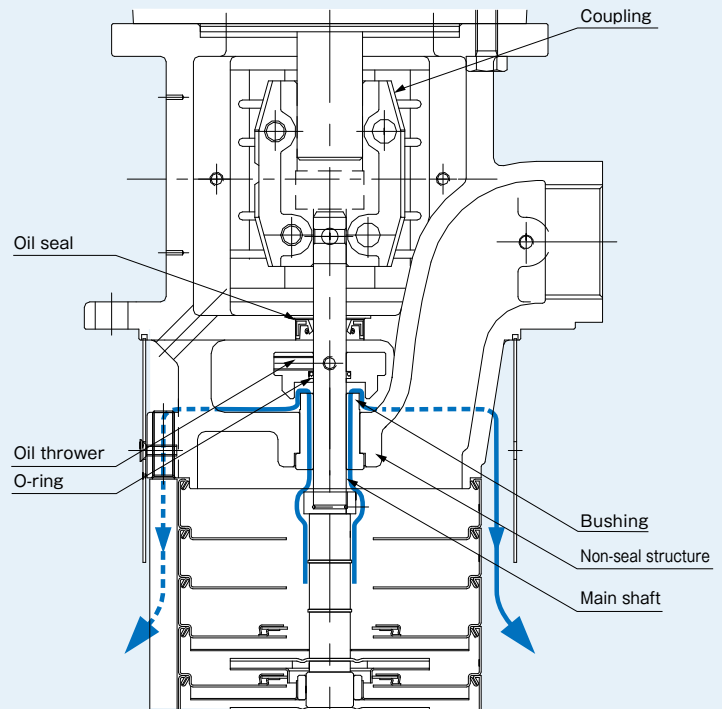

Description of types

50 LVSS 10 - 20 / 12 - 6 7.5 -e

① ② ③ ④ ⑤ ⑥ ⑦ ⑧

- ① Discharge diameter
- ② Model
- ③ Nominal flow rate (m³/h)
- ④ Number of casings
- ⑤ Number of impellers
- ⑥ Frequency 5:50Hz 6:60Hz
- ⑦ Output
- ⑧ Motor efficiency -e : Top Runner efficiency(equivalent to IE3)
-KS : Equipped with Korea Energy Efficiency Label and Standard Program compliant motor (IE3)
-7W : Equipped with NEMA Premium efficiency, UL/CSA certified motor (Output less than 0.75kW complies to safety standards only)

Standard Specification

Used liquid	Property of liquid	Fresh water, Cleaning liquid and Water soluble coolants (e.g. grinding liquid, cutting liquid after secondary treatment) *1
	Temperature	0 to 90° C (No frozen liquid)
	Allowable kinematic viscosity	1mm ² /s
Installation location		Indoor Ambient temperature: 0 to 40° C, RH 85% or below (no condensation), Height above sea level : 1000m or less, Place not exposed to direct sunlight, Place in an area free of corrosive or explosive gas or vapor.
Material	Suction casing	Bore diameter 32: SCS14A, Bore diameter 50: SCS13
	Discharge casing	SCS13+SUS430
	Intermediate casing	SUS304
	Impeller	SUS304
	Main shaft	SUS420J2
Shaft seal structure		Non-seal (mechanical seal-less)
Motor	Type	Totally enclosed fan-cooled outdoor type *2
	Protection method	IP55
	Power source	3-phase 50/60/60Hz, 200/200/230V 0.75~7.5kW *3 3-phase 50/60/60Hz, 200/200/220V 11~18.5kW
	Thermal class	F *4
	Number of poles	2P
	Standard	IEC60034-1
Paint color	Pump	Munsell N1 (Frame spacer for 5.5kW or more)
	Motor	Black

*1 If the liquid contains hard sludge, such as abrasive powder, ground powder, or ground diamond grains, the service life might be shortened. Please set up a filter (magnet filter or paper filter, etc.).

*2 The pump cannot be installed outside.

*3 -KS/-7W:3-phase 60Hz 200V-230V

*4 Thermal class of -7W type is class A.

Special specification

Motor modifications	Voltage change *1, change of terminal box position *2, change of terminal box direction *3
---------------------	--

*1 7.5kW or less (50Hz/380V,400V 60Hz/400V 460V)

11kW or more(50Hz/380V,400V,415V,420V,440V 60Hz/400V,440V,460V 480V)

*2 Change of terminal box position (every 90° when viewed from above)

*3 Terminal box direction (every 90° when viewed from front), Applicable: 1.5 kW to 18.5 kW

Special accessory

Companion flange (discharge diameter 32 mm) *

* The material is SCS13.

Table of Consumable Parts

Output (kW)	Bearing		Oil seal				O-ring (For oil thrower) Material: FKM	
	Load side	Unload side	Motor		Discharge casing		Bore diameter 32	Bore diameter 50
			Load side (Bearing side)	Unload side	Bore diameter 32	Bore diameter 50		
0.75	6204ZZC3	6201ZZC3	—	—	IS12257	SC16328	S12	S16
1.1		6304ZZC3	—	—				
1.5	6205ZZC3		6304ZZC3	VC25407				
2.2		6307ZZC3		6305ZZC3				
3.0	6309ZZC3		6306ZZC3					
4.0		6309ZZC3		6306ZZC3				
5.5	7309B		6309ZZC3					
7.5		7309B		6309ZZC3				
11	7309B		6309ZZC3					
15		7309B		6309ZZC3				
18.5	7309B		6309ZZC3		Please contact us			

Selection chart

(Values at kinematic viscosity 1mm²/s, specific gravity 1)

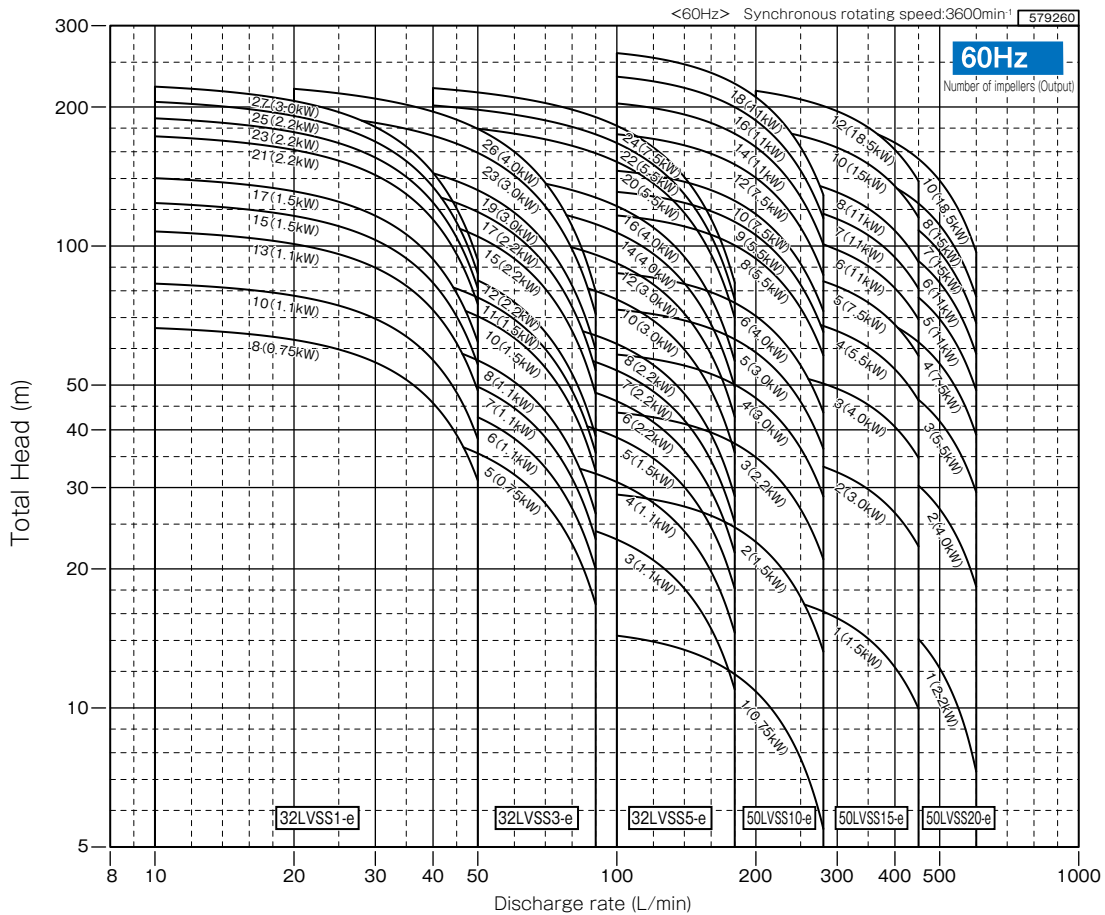
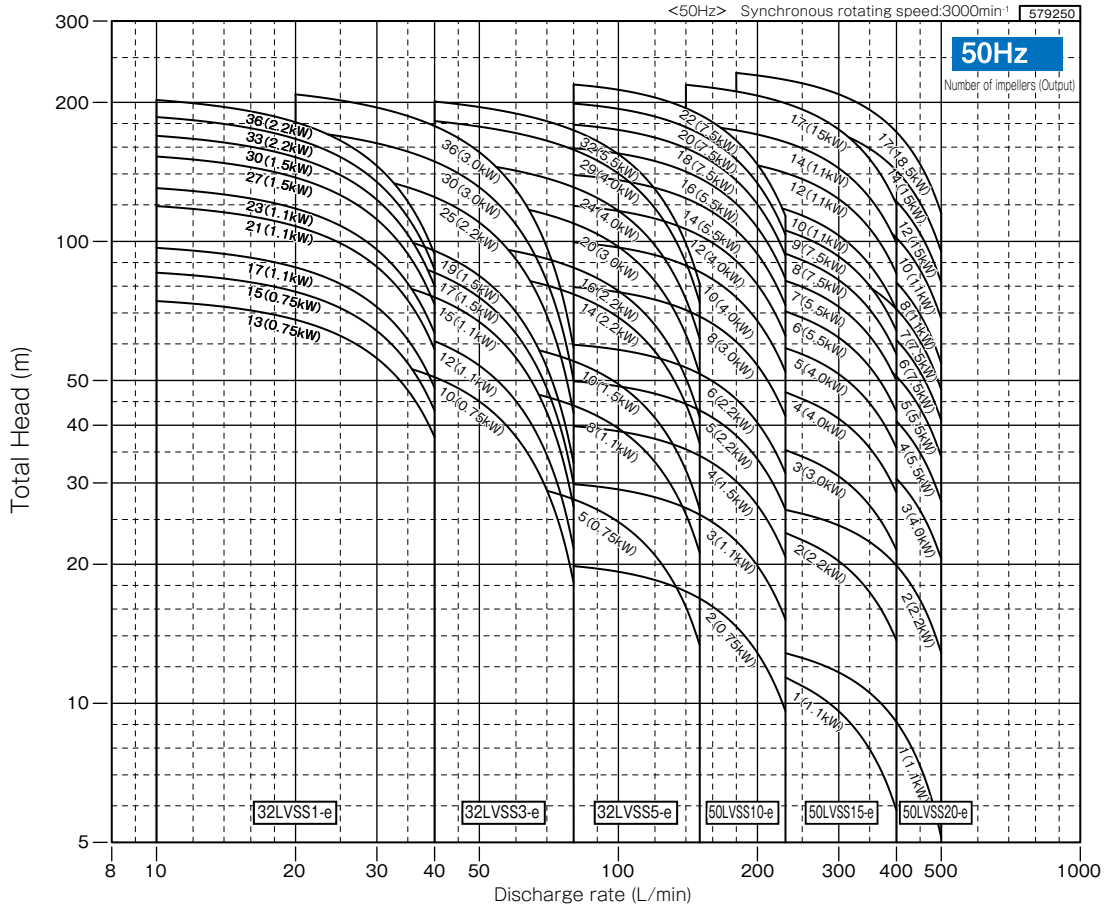

Note 1) The selection chart reflects the full impeller condition of the units. The total head may be decreased depending on the flow rate if empty casings are involved because of pressure loss in the empty casings.

* Above selection chart (-e) is also available for -KS/-7W type.

■ Pressure loss in the empty casings (50 Hz/60 Hz)

Pressure loss for 1 stage of empty casing is as follows:

LVSS1

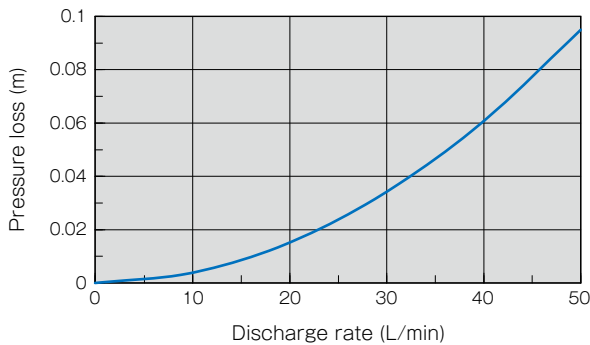

LVSS10

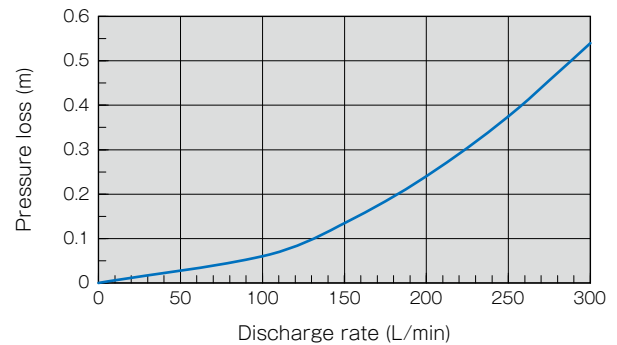

LVSS3

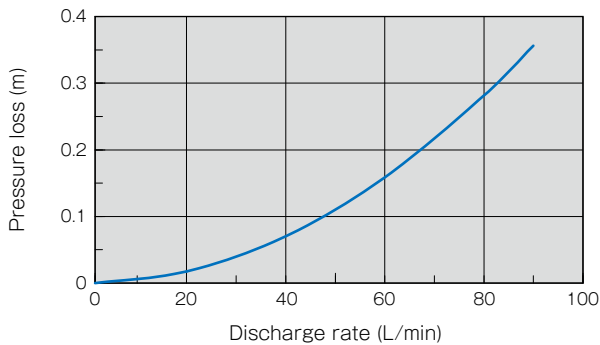

LVSS15

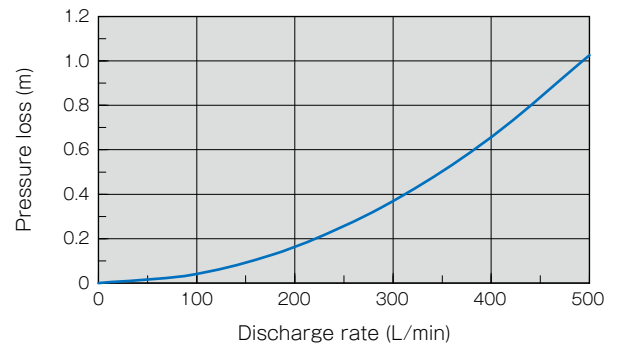

LVSS5

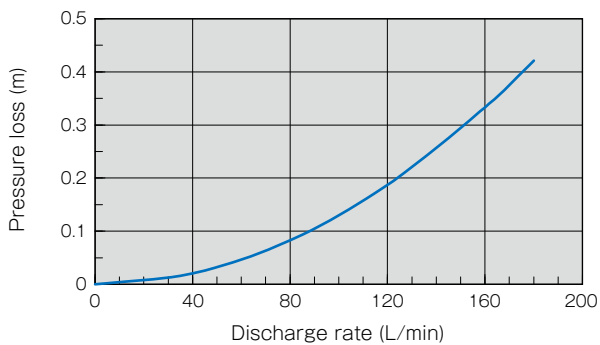

LVSS20

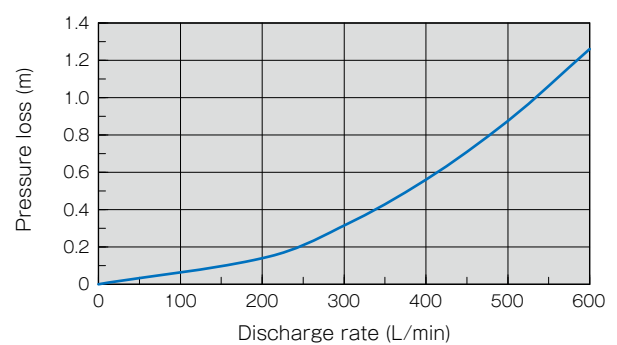

The selection chart is a performance chart of the full-impeller model (all casings are equipped with impeller). A pump with empty casings (without impeller) will have some influence on the total head of the pump depending on the flow rate due to its pressure loss.

The pressure loss per 1 stage of empty casing of each model is as shown in the graph above.

In the case of a pump with many stages of empty casings, the maximum flow rate may slightly decrease.

For details, refer to the characteristic curve chart.

● Calculation example of total pump head in consideration of pressure loss of empty casing

- Pump type : 32LVSS5-20/5-5.75-e
- Specification flow rate: 100L/min
- Specification total head: 20m
- The number of stages : 20
- Number of impellers : 5

From the graph above, the pressure loss per 1 stage of empty casing is 0.13 m for a flow rate of 100L/min

The number of stages of the empty casing is 20 - 5 = 15 stages.

Total pressure loss = $0.13 \times 15 \doteq 2.0\text{m}$

From the selection chart, the total head is 25 m for a flow rate of 100L/min.

The pressure loss is subtracted from the total head.

Total head = $25 - 2.0 = 23.0\text{m}$

Therefore, the total head of 32LVSS5-20/5-5.75-e is 23.0 m for a flow rate of 100 L/min.

Specification table

●-e type

50Hz

Bore diameter (mm)	Nominal flow rate (m ³ /h)	Type	Output (kW)	Rated voltage (V)	Rated current (A)	Starting current (A)	Discharge rate (L/min)	Total Head (m)		
32	1	32LVSS1-□/13-5.75-e	0.75	200	3.4	26	10-40	74.3 - 37.7		
		32LVSS1-□/15-5.75-e						85.6 - 43.0		
		32LVSS1-□/17-51.1-e	1.1		4.7	34		96.8 - 48.2		
		32LVSS1-□/21-51.1-e						119.3 - 58.4		
		32LVSS1-□/23-51.1-e	1.5		6.2	47		130.4 - 63.3		
		32LVSS1-□/27-51.5-e						152.7 - 73.0		
		32LVSS1-□/30-51.5-e	2.2		8.7	83		169.3 - 80.1		
		32LVSS1-□/33-52.2-e						185.9 - 87.0		
	32LVSS1-36/36-52.2-e					202.4 - 93.8				
	3	3	32LVSS3-□/10-5.75-e		0.75	3.4	26	20-80	58.7 - 18.2	
			32LVSS3-□/12-51.1-e		1.1	4.7	34		70.3 - 21.6	
			32LVSS3-□/15-51.1-e						87.7 - 26.6	
			32LVSS3-□/17-51.5-e		1.5	6.2	47		99.3 - 29.9	
			32LVSS3-□/19-51.5-e						110.9 - 33.1	
			32LVSS3-□/25-52.2-e		2.2	8.7	83		145.4 - 42.5	
		32LVSS3-□/30-53.0-e	3.0		12.2	129	174.0 - 50.0			
		32LVSS3-36/36-53.0-e					208.2 - 58.8			
		5	5		32LVSS5-□/5-5.75-e	0.75	3.4	26	40-150	31.6 - 13.3
					32LVSS5-□/8-51.1-e	1.1	4.7	34		50.6 - 21.1
					32LVSS5-□/10-51.5-e	1.5	6.2	47		63.2 - 26.3
					32LVSS5-□/14-52.2-e					88.3 - 36.5
	32LVSS5-□/16-52.2-e		2.2		8.7	83	100.9 - 41.6			
	32LVSS5-□/20-53.0-e						126.0 - 51.6			
	32LVSS5-□/24-54.0-e		4.0		14.7	145	151.0 - 61.5			
32LVSS5-□/29-54.0-e	182.2 - 73.7									
32LVSS5-32/32-55.5-e	5.5	20.3	204	200.9 - 81.0						
50	10	50LVSS10-□/2-5.75-e	0.75	3.4	26	80-230	19.8 - 9.6			
		50LVSS10-□/3-51.1-e	1.1	4.7	34		29.8 - 15.1			
		50LVSS10-□/4-51.5-e	1.5	6.2	47		39.8 - 20.7			
		50LVSS10-□/5-52.2-e	2.2	8.7	83		49.8 - 26.2			
		50LVSS10-□/6-52.2-e					59.7 - 31.4			
		50LVSS10-□/8-53.0-e	3.0	12.2	129		79.6 - 41.8			
		50LVSS10-□/10-54.0-e	4.0	14.7	145		99.5 - 52.1			
		50LVSS10-□/12-54.0-e					119.4 - 62.4			
		50LVSS10-□/14-55.5-e	5.5	20.3	204		139.3 - 72.7			
		50LVSS10-□/16-55.5-e					159.1 - 82.9			
		50LVSS10-□/18-57.5-e	7.5	27.2	290		179.0 - 93.2			
		50LVSS10-□/20-57.5-e					198.9 - 103.3			
	50LVSS10-22/22-57.5-e				218.7 - 113.5					
	15	15	50LVSS15-□/1-51.1-e	1.1	4.7	34	140-400	12.7 - 5.8		
			50LVSS15-□/2-52.2-e	2.2	8.7	83		25.6 - 13.6		
			50LVSS15-□/3-53.0-e	3.0	12.2	129		38.6 - 21.4		
			50LVSS15-□/4-54.0-e	4.0	14.7	145		51.4 - 28.6		
			50LVSS15-□/5-54.0-e					64.3 - 35.7		
			50LVSS15-□/6-55.5-e	5.5	20.3	204		77.2 - 42.8		
		50LVSS15-□/7-55.5-e	90.0 - 49.9							
		50LVSS15-□/8-57.5-e	7.5	27.2	290	102.9 - 57.0				
		50LVSS15-□/9-57.5-e				115.7 - 64.1				
		50LVSS15-□/10-511-e	11	40.5	361	128.5 - 71.1				
		50LVSS15-□/12-511-e				154.2 - 85.2				
		50LVSS15-□/14-511-e	15	52.4	484	179.9 - 99.3				
	50LVSS15-17/17-515-e	218.4 - 120.4								
	20	20	50LVSS20-□/1-51.1-e	1.1	4.7	34	180-500	13.4 - 5.1		
			50LVSS20-□/2-52.2-e	2.2	8.7	83		27.1 - 12.8		
			50LVSS20-□/3-54.0-e	4.0	14.7	145		40.9 - 20.5		
			50LVSS20-□/4-55.5-e	5.5	20.3	204		54.6 - 27.3		
			50LVSS20-□/5-55.5-e					68.2 - 34.1		
			50LVSS20-□/6-57.5-e	7.5	27.2	290		81.8 - 40.9		
		50LVSS20-□/7-57.5-e	95.5 - 47.7							
		50LVSS20-□/8-511-e	11	40.5	361	109.1 - 54.5				
		50LVSS20-□/10-511-e				136.4 - 68.0				
		50LVSS20-□/12-515-e	15	54.0	484	163.6 - 81.5				
50LVSS20-□/14-515-e		190.8 - 95.0								
50LVSS20-17/17-518-e		18.5	66.0	563	231.7 - 115.1					

Note) The rated current in the table above is the recommended setting for the current value of the protective device.

●-e type

60Hz

Bore diameter (mm)	Nominal flow rate (m ³ /h)	Type	Output (kW)	Rated voltage (V)	Rated current (A)	Starting current (A)	Discharge rate (L/min)	Total Head (m)							
32	1	32LVSS1-□/8-6.75-e	0.75	200/230	3.2/3.1	25.0/28.5	10-50	66.4 - 31.1							
		32LVSS1-□/10-61.1-e	1.1		4.4/4.1	32.5/37.0		82.9 - 38.2							
		32LVSS1-□/13-61.1-e			2.2	5.9/5.4		41.0/47.6	107.6 - 48.6						
		32LVSS1-□/15-61.5-e	1.5			8.4/7.6		78.0/82.6	123.9 - 55.4						
		32LVSS1-□/17-61.5-e	3.0					11.5/10.8	115/135	140.3 - 62.0					
		32LVSS1-□/21-62.2-e								172.8 - 74.8					
		32LVSS1-□/23-62.2-e	189.1 - 81.1												
		32LVSS1-□/25-62.2-e	205.3 - 87.2												
	32LVSS1-□/27-63.0-e	221.4 - 93.2													
	32LVSS3-□/5-6.75-e	0.75	3.2/3.1		25.0/28.5	20-90	42.7 - 16.7								
	32LVSS3-□/6-61.1-e	1.1	4.4/4.1		32.5/37.0		51.2 - 20.0								
	32LVSS3-□/7-61.1-e		1.5		5.9/5.4		41.0/47.6	59.7 - 23.1							
	32LVSS3-□/8-61.1-e	68.1 - 26.3													
	32LVSS3-□/10-61.5-e	85.0 - 32.6													
	32LVSS3-□/11-61.5-e	93.5 - 35.7													
	32LVSS3-□/12-62.2-e	101.9 - 38.7													
	32LVSS3-□/15-62.2-e	127.1 - 47.8													
	32LVSS3-□/17-62.2-e	143.9 - 53.8													
	32LVSS3-□/19-63.0-e	3.0	11.5/10.8		115/135	160.7 - 59.6									
	32LVSS3-□/23-63.0-e					194.1 - 71.2									
	32LVSS3-□/26-64.0-e	4.0	14.3/12.8		132/151	219.0 - 79.7									
	5	3	32LVSS5-□/3-61.1-e		1.1	200/230	4.4/4.1	32.5/37.0	40-180	27.7 - 10.9					
			32LVSS5-□/4-61.1-e							36.9 - 14.5					
			32LVSS5-□/5-61.5-e		1.5					5.9/5.4	41.0/47.6	46.1 - 18.1			
			32LVSS5-□/6-62.2-e									55.3 - 21.6			
			32LVSS5-□/7-62.2-e									64.4 - 25.2			
			32LVSS5-□/8-62.2-e									73.6 - 28.7			
		32LVSS5-□/10-63.0-e	3.0		11.5/10.8		115/135	92.0 - 35.7							
		32LVSS5-□/12-63.0-e						110.3 - 42.6							
		32LVSS5-□/14-64.0-e	4.0		14.3/12.8		132/151	128.6 - 49.5							
		32LVSS5-□/16-64.0-e						146.9 - 56.4							
		32LVSS5-□/20-65.5-e	5.5		19.8/17.8		178/206	183.4 - 69.9							
32LVSS5-□/22-65.5-e		201.6 - 76.6													
32LVSS5-□/24-67.5-e	7.5	26.5/23.7	254/295	219.8 - 83.3											
50	10	50LVSS10-□/1-6.75-e	0.75	200/220	3.2/3.1	25.0/28.5	100-280	14.3 - 5.4							
		50LVSS10-□/2-61.5-e	1.5		5.9/5.4	41.0/47.6		28.9 - 13.2							
		50LVSS10-□/3-62.2-e	2.2		8.4/7.6	78.0/82.6		43.6 - 20.9							
		50LVSS10-□/4-63.0-e						3.0	11.5/10.8	115/135	58.2 - 28.7				
		50LVSS10-□/5-63.0-e	72.8 - 36.4												
		50LVSS10-□/6-64.0-e	87.4 - 43.6												
		50LVSS10-□/8-65.5-e	5.5		19.8/17.8	178/206					116.5 - 57.9				
		50LVSS10-□/9-65.5-e						131.0 - 65.1							
		50LVSS10-□/10-67.5-e	7.5		26.5/23.7	254/295		145.5 - 72.2							
		50LVSS10-□/12-67.5-e						174.6 - 86.5							
		50LVSS10-□/14-611-e	11		39.5/36.5	296/333		203.7 - 100.7							
		50LVSS10-□/16-611-e						232.7 - 114.8							
	50LVSS10-□/18-611-e	261.7 - 129.0													
	50LVSS15-□/1-61.5-e	1.5					200/230	5.9/5.4	41.0/47.6	18.3 - 9.9					
	50LVSS15-□/2-63.0-e	3.0	11.5/10.8		115/135	37.0 - 22.3									
	50LVSS15-□/3-64.0-e	4.0				14.3/12.8				132/151	55.6 - 34.7				
	50LVSS15-□/4-65.5-e	5.5									19.8/17.8	178/206	74.2 - 46.3		
	50LVSS15-□/5-67.5-e	7.5											26.5/23.7	254/295	92.7 - 57.8
	50LVSS15-□/6-611-e	11													39.5/36.5
	50LVSS15-□/7-611-e							129.8 - 80.8							
	50LVSS15-□/8-611-e		148.3 - 92.3												
	50LVSS15-□/10-615-e		15		53.0/49.0	397/447		185.3 - 115.3							
	50LVSS15-□/12-618-e	18.5	65.0/59.0					456/515	222.4 - 138.2						
	50LVSS20-□/1-62.2-e	2.2							200/230	8.4/7.8	78.0/82.6	19.2 - 7.2			
	50LVSS20-□/2-64.0-e	4.0										14.3/12.8	132/151	39.0 - 18.3	
	50LVSS20-□/3-65.5-e	5.5			19.8/17.8	178/206	58.8 - 29.3								
	50LVSS20-□/4-67.5-e	7.5	26.5/23.7				254/295	78.4 - 39.0							
	50LVSS20-□/5-611-e	11						39.5/36.5						296/333	98.0 - 48.7
	50LVSS20-□/6-611-e														117.6 - 58.4
	50LVSS20-□/7-615-e									15	53.0/49.0				397/447
	50LVSS20-□/8-615-e											156.8 - 77.7			
	50LVSS20-□/10-618-e	18.5			65.0/59.0	456/515		195.9 - 97.0							

Note) The rated current in the table above is the recommended setting for the current value of the protective device.

●-7W type

60Hz

Bore diameter (mm)	Nominal flow rate (m³/h)	Type	Output (kW)	Rated voltage (V)	Rated current (A)	Starting current (A)	Discharge rate (L/min)	Total Head (m)			
32	1	32LVSS1-□/8-6.75-7W	0.75	200-230	3.2-3.1	25.0-28.5	10-50	66.4 - 31.1			
		32LVSS1-□/10-61.1-7W	1.1		4.4-4.1	32.5-37.0		82.9 - 38.2			
		32LVSS1-□/13-61.1-7W			2.2	8.4-7.6		78.0-82.6	107.6 - 48.6		
		32LVSS1-□/15-61.5-7W	1.5						5.9-5.4	41.0-47.6	123.9 - 55.4
		32LVSS1-□/17-61.5-7W									2.2
		32LVSS1-□/21-62.2-7W	1.1						4.4-4.1	32.5-37.0	
		32LVSS1-□/23-62.2-7W									1.5
		32LVSS1-□/25-62.2-7W	2.2						8.4-7.6	78.0-82.6	
	32LVSS1-□/27-63.0-7W	1.1			4.4-4.1	32.5-37.0	221.4 - 93.2				
	32LVSS3-□/5-6.75-7W		0.75				3.2-3.1	25.0-28.5	20-90	42.7 - 16.7	
	32LVSS3-□/6-61.1-7W	1.1			4.4-4.1	32.5-37.0				51.2 - 20.0	
	32LVSS3-□/7-61.1-7W		1.5				5.9-5.4	41.0-47.6		59.7 - 23.1	
	32LVSS3-□/8-61.1-7W	2.2			8.4-7.6	78.0-82.6				68.1 - 26.3	
	32LVSS3-□/10-61.5-7W		1.1				4.4-4.1	32.5-37.0		85.0 - 32.6	
	32LVSS3-□/11-61.5-7W	1.5			5.9-5.4	41.0-47.6				93.5 - 35.7	
	32LVSS3-□/12-62.2-7W		2.2				8.4-7.6	78.0-82.6		101.9 - 38.7	
	32LVSS3-□/15-62.2-7W	1.1			4.4-4.1	32.5-37.0				127.1 - 47.8	
	32LVSS3-□/17-62.2-7W		1.5				5.9-5.4	41.0-47.6	143.9 - 53.8		
	32LVSS3-□/19-63.0-7W	2.2			8.4-7.6	78.0-82.6			160.7 - 59.6		
	32LVSS3-□/23-63.0-7W		1.1				4.4-4.1	32.5-37.0	194.1 - 71.2		
	32LVSS3-□/26-64.0-7W	1.5			5.9-5.4	41.0-47.6			219.0 - 79.7		
	32LVSS5-□/3-61.1-7W		0.75				3.2-3.1	25.0-28.5	40-180	27.7 - 10.9	
	32LVSS5-□/4-61.1-7W	1.1			4.4-4.1	32.5-37.0				36.9 - 14.5	
	32LVSS5-□/5-61.5-7W		1.5				5.9-5.4	41.0-47.6		46.1 - 18.1	
	32LVSS5-□/6-62.2-7W	2.2			8.4-7.6	78.0-82.6				55.3 - 21.6	
	32LVSS5-□/7-62.2-7W		1.1				4.4-4.1	32.5-37.0		64.4 - 25.2	
	32LVSS5-□/8-62.2-7W	1.5			5.9-5.4	41.0-47.6				73.6 - 28.7	
	32LVSS5-□/10-63.0-7W		2.2				8.4-7.6	78.0-82.6		92.0 - 35.7	
	32LVSS5-□/12-63.0-7W	1.1			4.4-4.1	32.5-37.0				110.3 - 42.6	
	32LVSS5-□/14-64.0-7W		1.5				5.9-5.4	41.0-47.6		128.6 - 49.5	
	32LVSS5-□/16-64.0-7W	2.2			8.4-7.6	78.0-82.6				146.9 - 56.4	
	32LVSS5-□/20-65.5-7W		1.1				4.4-4.1	32.5-37.0		183.4 - 69.9	
32LVSS5-□/22-65.5-7W	1.5	5.9-5.4		41.0-47.6	201.6 - 76.6						
32LVSS5-□/24-67.5-7W			2.2		8.4-7.6	78.0-82.6	219.8 - 83.3				
50	10	50LVSS10-□/1-6.75-7W		0.75			200-230	3.2-3.1	25.0-28.5	100-280	14.3 - 5.4
		50LVSS10-□/2-61.5-7W	1.5	5.9-5.4	41.0-47.6	28.9 - 13.2					
		50LVSS10-□/3-62.2-7W	2.2	8.4-7.6	78.0-82.6	43.6 - 20.9					
		50LVSS10-□/4-63.0-7W	3.0	11.3-10.6	115-135	58.2 - 28.7					
		50LVSS10-□/5-63.0-7W				4.0		14.3-12.8	132-151		72.8 - 36.4
		50LVSS10-□/6-64.0-7W	5.5	19.8-17.8	178-206						87.4 - 43.6
		50LVSS10-□/8-65.5-7W				7.5		26.5-23.7	254-295		116.5 - 57.9
		50LVSS10-□/9-65.5-7W	1.5	5.9-5.4	41.0-47.6						131.0 - 65.1
		50LVSS10-□/10-67.5-7W				3.0		11.3-10.6	115-135		145.5 - 72.2
		50LVSS10-□/12-67.5-7W	4.0	14.3-12.8	132-151						174.6 - 86.5
	50LVSS15-□/1-61.5-7W	1.5				5.9-5.4		41.0-47.6	160-450	18.3 - 9.9	
	50LVSS15-□/2-63.0-7W		3.0	11.3-10.6	115-135					37.0 - 22.3	
	50LVSS15-□/3-64.0-7W	4.0				14.3-12.8		132-151		55.6 - 34.7	
	50LVSS15-□/4-65.5-7W		5.5	19.8-17.8	178-206					74.2 - 46.3	
	50LVSS15-□/5-67.5-7W	7.5				26.5-23.7		254-295		92.7 - 57.8	
	50LVSS20-□/1-62.2-7W		2.2	8.4-7.8	78.0-82.6					220-600	19.2 - 7.2
	50LVSS20-□/2-64.0-7W	4.0				14.3-12.8		132-151	39.0 - 18.3		
	50LVSS20-□/3-65.5-7W		5.5	19.8-17.8	178-206				58.8 - 29.3		
	50LVSS20-□/4-67.5-7W	7.5				26.5-23.7		254-295	78.4 - 39.0		

Note 1) The rated current is the recommended current setting for the protection device.

●-KS type

60Hz

Bore diameter (mm)	Nominal flow rate (m ³ /h)	Type	Output (kW)	Rated voltage (V)	Rated current (A)	Starting current (A)	Discharge rate (L/min)	Total Head (m)	
32	1	32LVSS1-□/8-6.75-KS	0.75	200-230	3.2-3.1	25.0-28.5	10-50	66.4 - 31.1	
		32LVSS1-□/10-61.1-KS	1.1		4.4-4.1	32.5-37.0		82.9 - 38.2	
		32LVSS1-□/13-61.1-KS			1.5	5.9-5.4		41.0-47.6	107.6 - 48.6
		32LVSS1-□/15-61.5-KS	2.2			8.4-7.6		78.0-82.6	123.9 - 55.4
		32LVSS1-□/17-61.5-KS			3.0	11.5-10.8		115-135	140.3 - 62.0
		32LVSS1-□/21-62.2-KS	4.0			14.3-12.8		132-151	172.8 - 74.8
		32LVSS1-□/23-62.2-KS			5.5	19.8-17.8		178-206	189.1 - 81.1
		32LVSS1-□/25-62.2-KS	7.5			26.5-23.7		254-295	205.3 - 87.2
	32LVSS1-□/27-63.0-KS	8.4-7.6			78.0-82.6	221.4 - 93.2			
	3	0.75	32LVSS3-□/5-6.75-KS		0.75	3.2-3.1	25.0-28.5	20-90	42.7 - 16.7
			32LVSS3-□/6-61.1-KS		1.1	4.4-4.1	32.5-37.0		51.2 - 20.0
		32LVSS3-□/7-61.1-KS	1.5			5.9-5.4	41.0-47.6		59.7 - 23.1
		32LVSS3-□/8-61.1-KS			2.2	8.4-7.6	78.0-82.6		68.1 - 26.3
		32LVSS3-□/10-61.5-KS	3.0			11.5-10.8	115-135		85.0 - 32.6
		32LVSS3-□/11-61.5-KS			4.0	14.3-12.8	132-151		93.5 - 35.7
		32LVSS3-□/12-62.2-KS	5.5			19.8-17.8	178-206		101.9 - 38.7
		32LVSS3-□/15-62.2-KS			7.5	26.5-23.7	254-295		127.1 - 47.8
		32LVSS3-□/17-62.2-KS	8.4-7.6			78.0-82.6	143.9 - 53.8		
		32LVSS3-□/19-63.0-KS			11.3-10.6	115-135	160.7 - 59.6		
		32LVSS3-□/23-63.0-KS	14.3-12.8			132-151	194.1 - 71.2		
		32LVSS3-□/26-64.0-KS			14.3-12.8	132-151	219.0 - 79.7		
	5	1.1	32LVSS5-□/3-61.1-KS		1.1	4.4-4.1	32.5-37.0	40-180	27.7 - 10.9
			32LVSS5-□/4-61.1-KS		1.5	5.9-5.4	41.0-47.6		36.9 - 14.5
		32LVSS5-□/5-61.5-KS	2.2			8.4-7.6	78.0-82.6		46.1 - 18.1
		32LVSS5-□/6-62.2-KS			3.0	11.3-10.6	115-135		55.3 - 21.6
		32LVSS5-□/7-62.2-KS	4.0			14.3-12.8	132-151		64.4 - 25.2
		32LVSS5-□/8-62.2-KS			5.5	19.8-17.8	178-206		73.6 - 28.7
		32LVSS5-□/10-63.0-KS	7.5			26.5-23.7	254-295		92.0 - 35.7
		32LVSS5-□/12-63.0-KS			8.4-7.6	78.0-82.6	110.3 - 42.6		
		32LVSS5-□/14-64.0-KS	11.3-10.6			115-135	128.6 - 49.5		
		32LVSS5-□/16-64.0-KS			14.3-12.8	132-151	146.9 - 56.4		
		32LVSS5-□/20-65.5-KS	19.8-17.8			178-206	183.4 - 69.9		
32LVSS5-□/22-65.5-KS		26.5-23.7		254-295	201.6 - 76.6				
32LVSS5-□/24-67.5-KS	26.5-23.7		254-295	219.8 - 83.3					
50	10	50LVSS10-□/1-6.75-KS	0.75	3.2-3.1	25.0-28.5	100-280	14.3 - 5.4		
		50LVSS10-□/2-61.5-KS	1.5	5.9-5.4	41.0-47.6		28.9 - 13.2		
		50LVSS10-□/3-62.2-KS	2.2	8.4-7.6	78.0-82.6		43.6 - 20.9		
		50LVSS10-□/4-63.0-KS	3.0	11.3-10.6	115-135		58.2 - 28.7		
		50LVSS10-□/5-63.0-KS		4.0	14.3-12.8		132-151	72.8 - 36.4	
		50LVSS10-□/6-64.0-KS	5.5		19.8-17.8		178-206	87.4 - 43.6	
		50LVSS10-□/8-65.5-KS		7.5	26.5-23.7		254-295	116.5 - 57.9	
		50LVSS10-□/9-65.5-KS	8.4-7.6		78.0-82.6		131.0 - 65.1		
		50LVSS10-□/10-67.5-KS		11.3-10.6	115-135		145.5 - 72.2		
		50LVSS10-□/12-67.5-KS	14.3-12.8		132-151		174.6 - 86.5		
	15	50LVSS15-□/1-61.5-KS		1.5	5.9-5.4	41.0-47.6	160-450	18.3 - 9.9	
		50LVSS15-□/2-63.0-KS	3.0	11.3-10.6	115-135	37.0 - 22.3			
		50LVSS15-□/3-64.0-KS	4.0	14.3-12.8	132-151	55.6 - 34.7			
		50LVSS15-□/4-65.5-KS	5.5	19.8-17.8	178-206	74.2 - 46.3			
		50LVSS15-□/5-67.5-KS	7.5	26.5-23.7	254-295	92.7 - 57.8			
	20	50LVSS20-□/1-62.2-KS	2.2	8.4-7.8	78.0-82.6	220-600	19.2 - 7.2		
		50LVSS20-□/2-64.0-KS	4.0	14.3-12.8	132-151		39.0 - 18.3		
		50LVSS20-□/3-65.5-KS	5.5	19.8-17.8	178-206		58.8 - 29.3		
		50LVSS20-□/4-67.5-KS	7.5	26.5-23.7	254-295		78.4 - 39.0		

Note 1) The rated current is the recommended current setting for the protection device.

Assembly drawing

● Discharge diameter: 32mm

Fig.1

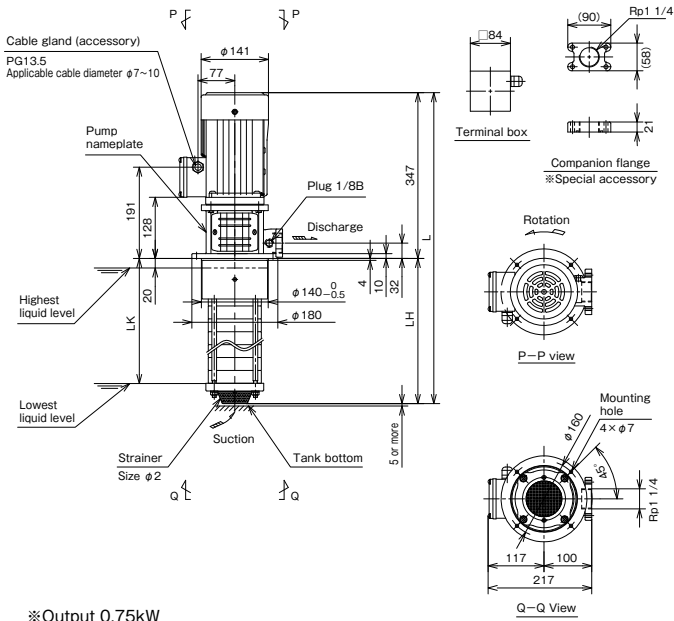

※Output 0.75kW

Fig.2

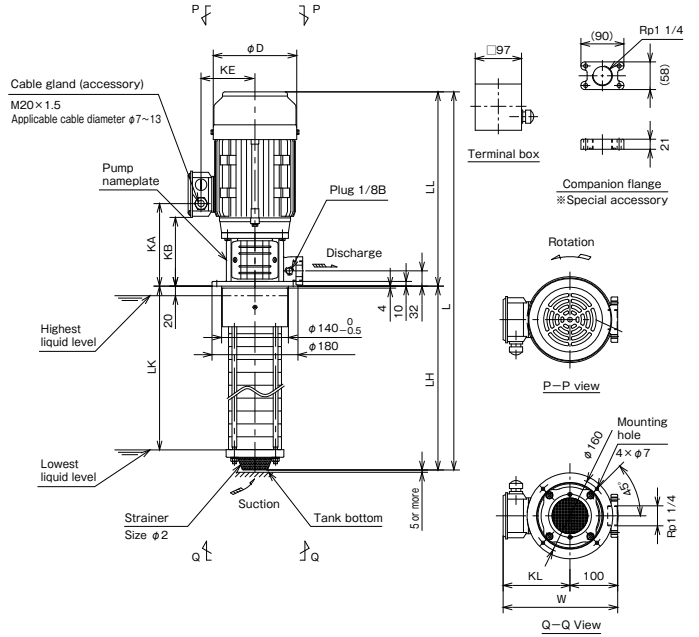

(Unit : mm)

Output kW	D	KA	KB	KE	KL	LL	W
1.1	175	167	138	113	140	401	240
1.5/2.2	175	173	144	113	140	407	240
3.0	196	174	144	125	152	430	252
4.0	219	178	149	134	161	437	—

Fig.3

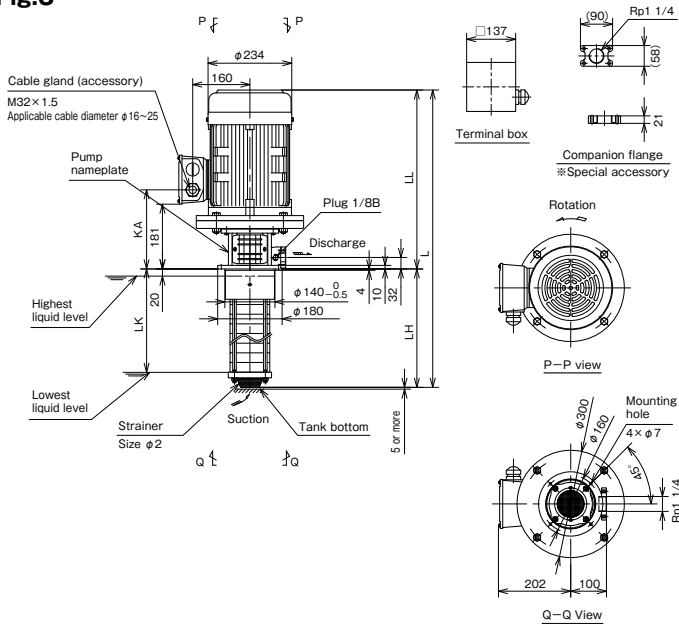

(Unit : mm)

Output kW	LL	KA
5.5	500	221
7.5	540	222

■ Dimensions

●Discharge diameter : 32mm, Nominal flow rate : 1m³/h

50Hz

(Unit : mm)

Type	Fig.	L	LH	LK	Approx. mass(kg)
32LVSS1-13/13-5.75-e	1	696	349	307	23
32LVSS1-15/13-5.75-e		732	385	343	24
32LVSS1-17/13-5.75-e		768	421	379	24
32LVSS1-21/13-5.75-e		840	493	451	25
32LVSS1-25/13-5.75-e		912	565	523	26
32LVSS1-15/15-5.75-e		732	385	343	24
32LVSS1-17/15-5.75-e		768	421	379	24
32LVSS1-21/15-5.75-e		840	493	451	25
32LVSS1-25/15-5.75-e		912	565	523	26
32LVSS1-17/17-51.1-e		822	421	379	29.5
32LVSS1-21/17-51.1-e	894	493	451	29.5	
32LVSS1-25/17-51.1-e	966	565	523	30.5	
32LVSS1-30/17-51.1-e	1056	655	613	32.5	
32LVSS1-21/21-51.1-e	894	493	451	30.5	
32LVSS1-25/21-51.1-e	966	565	523	31.5	
32LVSS1-30/21-51.1-e	1056	655	613	32.5	
32LVSS1-33/21-51.1-e	1110	709	667	32.5	
32LVSS1-23/23-51.1-e	930	529	487	30.5	
32LVSS1-25/23-51.1-e	966	565	523	31.5	
32LVSS1-30/23-51.1-e	1056	655	613	32.5	
32LVSS1-33/23-51.1-e	1110	709	667	33.5	
32LVSS1-36/23-51.1-e	1164	763	721	33.5	
32LVSS1-27/27-51.5-e	1008	601	559	36	
32LVSS1-33/27-51.5-e	1116	709	667	37	
32LVSS1-36/27-51.5-e	1170	763	721	38	
32LVSS1-30/30-51.5-e	1062	655	613	36	
32LVSS1-33/30-51.5-e	1116	709	667	37	
32LVSS1-36/30-51.5-e	1170	763	721	38	
32LVSS1-33/33-52.2-e	1116	709	667	41	
32LVSS1-36/33-52.2-e	1170	763	721	41	
32LVSS1-36/36-52.2-e	1170	763	721	41	

60Hz

(Unit : mm)

Type	Fig.	L	LH	LK	Approx. mass(kg)
32LVSS1-8/8-6.75-□	1	606	259	217	22
32LVSS1-10/8-6.75-□		642	295	253	22
32LVSS1-13/8-6.75-□		696	349	307	23
32LVSS1-15/8-6.75-□		732	385	343	24
32LVSS1-17/8-6.75-□		768	421	379	24
32LVSS1-21/8-6.75-□		840	493	451	25
32LVSS1-25/8-6.75-□		912	565	523	26
32LVSS1-10/10-61.1-□		696	295	253	27.5
32LVSS1-13/10-61.1-□		750	349	307	27.5
32LVSS1-15/10-61.1-□		786	385	343	28.5
32LVSS1-17/10-61.1-□	822	421	379	28.5	
32LVSS1-21/10-61.1-□	894	493	451	29.5	
32LVSS1-25/10-61.1-□	966	565	523	30.5	
32LVSS1-13/13-61.1-□	750	349	307	27.5	
32LVSS1-15/13-61.1-□	786	385	343	28.5	
32LVSS1-17/13-61.1-□	822	421	379	28.5	
32LVSS1-21/13-61.1-□	894	493	451	29.5	
32LVSS1-25/13-61.1-□	966	565	523	30.5	
32LVSS1-15/15-61.5-□	792	385	343	32	
32LVSS1-17/15-61.5-□	828	421	379	33	
32LVSS1-21/15-61.5-□	900	493	451	33	
32LVSS1-25/15-61.5-□	972	565	523	34	
32LVSS1-30/15-61.5-□	1062	655	613	36	
32LVSS1-17/17-61.5-□	828	421	379	33	
32LVSS1-21/17-61.5-□	900	493	451	34	
32LVSS1-25/17-61.5-□	972	565	523	35	
32LVSS1-30/17-61.5-□	1062	655	613	36	
32LVSS1-33/17-61.5-□	1116	709	667	36	
32LVSS1-21/21-62.2-□	900	493	451	37	
32LVSS1-25/21-62.2-□	972	565	523	38	
32LVSS1-30/21-62.2-□	1062	655	613	39	
32LVSS1-33/21-62.2-□	1116	709	667	40	
32LVSS1-36/21-62.2-□	1170	763	721	41	
32LVSS1-23/23-62.2-□	936	529	487	38	
32LVSS1-27/23-62.2-□	1008	601	559	39	
32LVSS1-30/23-62.2-□	1062	655	613	39	
32LVSS1-33/23-62.2-□	1116	709	667	40	
32LVSS1-36/23-62.2-□	1170	763	721	41	
32LVSS1-25/25-62.2-□	972	565	523	38	
32LVSS1-27/25-62.2-□	1008	601	559	39	
32LVSS1-30/25-62.2-□	1062	655	613	40	
32LVSS1-33/25-62.2-□	1116	709	667	40	
32LVSS1-36/25-62.2-□	1170	763	721	41	
32LVSS1-27/27-63.0-□	1031	601	559	46	
32LVSS1-30/27-63.0-□	1085	655	613	47	
32LVSS1-33/27-63.0-□	1139	709	667	47	
32LVSS1-36/27-63.0-□	1193	763	721	48	

Note 1) "□" in pump type can be any one of -e/-KS/-7W.

●Discharge diameter : 32mm, Nominal flow rate : 3m³/h

50Hz

(Unit : mm)

Type	Fig.	L	LH	LK	Approx. mass(kg)
32LVSS3-10/10-5.75-e	1	642	295	253	22
32LVSS3-12/10-5.75-e		678	331	289	23
32LVSS3-15/10-5.75-e		732	385	343	24
32LVSS3-19/10-5.75-e		804	457	415	25
32LVSS3-23/10-5.75-e		876	529	487	25
32LVSS3-12/12-51.1-e	2	732	331	289	28.5
32LVSS3-15/12-51.1-e		786	385	343	28.5
32LVSS3-19/12-51.1-e		858	457	415	29.5
32LVSS3-23/12-51.1-e		930	529	487	30.5
32LVSS3-15/15-51.1-e		786	385	343	28.5
32LVSS3-19/15-51.1-e		858	457	415	29.5
32LVSS3-23/15-51.1-e		930	529	487	30.5
32LVSS3-17/17-51.5-e		828	421	379	33
32LVSS3-23/17-51.5-e		936	529	487	34
32LVSS3-26/17-51.5-e		990	583	541	35
32LVSS3-19/19-51.5-e		864	457	415	33
32LVSS3-23/19-51.5-e		936	529	487	34
32LVSS3-26/19-51.5-e		990	583	541	35
32LVSS3-30/19-51.5-e		1062	655	613	36
32LVSS3-25/25-52.2-e		972	565	523	38
32LVSS3-30/25-52.2-e		1062	655	613	40
32LVSS3-36/25-52.2-e		1170	763	721	41
32LVSS3-30/30-53.0-e		1085	655	613	47
32LVSS3-36/30-53.0-e		1193	763	721	48
32LVSS3-36/36-53.0-e		1193	763	721	48

60Hz

(Unit : mm)

Type	Fig.	L	LH	LK	Approx. mass(kg)	
32LVSS3-5/5-6.75-□	1	552	205	163	21	
32LVSS3-7/5-6.75-□		588	241	199	21	
32LVSS3-10/5-6.75-□		642	295	253	22	
32LVSS3-12/5-6.75-□		678	331	289	23	
32LVSS3-15/5-6.75-□		732	385	343	23	
32LVSS3-19/5-6.75-□		804	457	415	24	
32LVSS3-23/5-6.75-□		876	529	487	25	
32LVSS3-6/6-61.1-□		2	624	223	181	25.5
32LVSS3-10/6-61.1-□			696	295	253	26.5
32LVSS3-12/6-61.1-□			732	331	289	27.5
32LVSS3-15/6-61.1-□			786	385	343	28.5
32LVSS3-19/6-61.1-□			858	457	415	28.5
32LVSS3-23/6-61.1-□			930	529	487	29.5
32LVSS3-7/7-61.1-□			642	241	199	26.5
32LVSS3-10/7-61.1-□			696	295	253	26.5
32LVSS3-12/7-61.1-□	732		331	289	27.5	
32LVSS3-15/7-61.1-□	786		385	343	28.5	
32LVSS3-19/7-61.1-□	858		457	415	28.5	
32LVSS3-23/7-61.1-□	930		529	487	29.5	
32LVSS3-8/8-61.1-□	660		259	217	26.5	
32LVSS3-10/8-61.1-□	696		295	253	26.5	
32LVSS3-12/8-61.1-□	732		331	289	27.5	
32LVSS3-15/8-61.1-□	786		385	343	28.5	
32LVSS3-19/8-61.1-□	858		457	415	29.5	
32LVSS3-23/8-61.1-□	930		529	487	29.5	
32LVSS3-10/10-61.5-□	702		295	253	31	
32LVSS3-12/10-61.5-□	738		331	289	31	
32LVSS3-15/10-61.5-□	792	385	343	32		
32LVSS3-19/10-61.5-□	864	457	415	33		
32LVSS3-23/10-61.5-□	936	529	487	34		
32LVSS3-11/11-61.5-□	720	313	271	31		
32LVSS3-15/11-61.5-□	792	385	343	32		
32LVSS3-19/11-61.5-□	864	457	415	33		
32LVSS3-23/11-61.5-□	936	529	487	34		
32LVSS3-12/12-62.2-□	738	331	289	35		
32LVSS3-15/12-62.2-□	792	385	343	35		
32LVSS3-19/12-62.2-□	864	457	415	36		
32LVSS3-23/12-62.2-□	936	529	487	37		
32LVSS3-15/15-62.2-□	792	385	343	36		
32LVSS3-19/15-62.2-□	864	457	415	36		
32LVSS3-23/15-62.2-□	936	529	487	37		
32LVSS3-26/15-62.2-□	990	583	541	38		
32LVSS3-17/17-62.2-□	828	421	379	36		
32LVSS3-23/17-62.2-□	936	529	487	37		
32LVSS3-26/17-62.2-□	990	583	541	38		
32LVSS3-30/17-62.2-□	1062	655	613	39		
32LVSS3-19/19-63.0-□	887	457	415	44		
32LVSS3-23/19-63.0-□	959	529	487	44		
32LVSS3-26/19-63.0-□	1013	583	541	45		
32LVSS3-30/19-63.0-□	1085	655	613	46		
32LVSS3-36/19-63.0-□	1193	763	721	47		
32LVSS3-23/23-63.0-□	959	529	487	45		
32LVSS3-26/23-63.0-□	1013	583	541	45		
32LVSS3-30/23-63.0-□	1085	655	613	46		
32LVSS3-36/23-63.0-□	1193	763	721	48		
32LVSS3-26/26-64.0-□	1020	583	541	51		
32LVSS3-30/26-64.0-□	1092	655	613	52		
32LVSS3-36/26-64.0-□	1200	763	721	53		

Note 1) "□" in pump type can be any one of -e/-KS/-7W.

●Discharge diameter : 32mm, Nominal flow rate : 5m³/h

50Hz

(Unit : mm)

Type	Fig.	L	LH	LK	Approx. mass(kg)
32LVSS5-5/5-5.75-e	1	597	250	208	22
32LVSS5-7/5-5.75-e		651	304	262	22
32LVSS5-10/5-5.75-e		732	385	343	23
32LVSS5-14/5-5.75-e		840	493	451	24
32LVSS5-16/5-5.75-e		894	547	505	25
32LVSS5-20/5-5.75-e		1002	655	613	26
32LVSS5-8/8-51.1-e	2	732	331	289	27.5
32LVSS5-10/8-51.1-e		786	385	343	27.5
32LVSS5-14/8-51.1-e		894	493	451	29.5
32LVSS5-16/8-51.1-e		948	547	505	29.5
32LVSS5-20/8-51.1-e		1056	655	613	31.5
32LVSS5-10/10-51.5-e		792	385	343	32
32LVSS5-14/10-51.5-e		900	493	451	33
32LVSS5-16/10-51.5-e		954	547	505	34
32LVSS5-20/10-51.5-e		1062	655	613	35
32LVSS5-14/14-52.2-e		900	493	451	37
32LVSS5-16/14-52.2-e		954	547	505	37
32LVSS5-20/14-52.2-e		1062	655	613	39
32LVSS5-24/14-52.2-e		1170	763	721	40
32LVSS5-16/16-52.2-e		954	547	505	37
32LVSS5-20/16-52.2-e		1062	655	613	39
32LVSS5-24/16-52.2-e		1170	763	721	40
32LVSS5-29/16-52.2-e		1305	898	856	41
32LVSS5-20/20-53.0-e		1085	655	613	46
32LVSS5-24/20-53.0-e		1193	763	721	47
32LVSS5-29/20-53.0-e		1328	898	856	49
32LVSS5-32/20-53.0-e		1409	979	937	50
32LVSS5-24/24-54.0-e		1200	763	721	53
32LVSS5-29/24-54.0-e		1335	898	856	54
32LVSS5-32/24-54.0-e		1416	979	937	55
32LVSS5-29/29-54.0-e	1335	898	856	54	
32LVSS5-32/29-54.0-e	1416	979	937	55	
32LVSS5-32/32-55.5-e	3	1479	979	937	83

60Hz

(Unit : mm)

Type	Fig.	L	LH	LK	Approx. mass(kg)
32LVSS5-3/3-61.1-□	1	597	196	154	25.5
32LVSS5-5/3-61.1-□		651	250	208	26.5
32LVSS5-7/3-61.1-□		705	304	262	26.5
32LVSS5-10/3-61.1-□		786	385	343	27.5
32LVSS5-14/3-61.1-□		894	493	451	28.5
32LVSS5-16/3-61.1-□		948	547	505	29.5
32LVSS5-20/3-61.1-□		1056	655	613	30.5
32LVSS5-4/4-61.1-□		624	223	181	25.5
32LVSS5-6/4-61.1-□		678	277	235	26.5
32LVSS5-8/4-61.1-□		732	331	289	26.5
32LVSS5-10/4-61.1-□		786	385	343	27.5
32LVSS5-14/4-61.1-□		894	493	451	29.5
32LVSS5-16/4-61.1-□		948	547	505	30.5
32LVSS5-20/4-61.1-□		1056	655	613	31.5
32LVSS5-5/5-61.5-□		657	250	208	30
32LVSS5-7/5-61.5-□		711	304	262	30
32LVSS5-10/5-61.5-□		792	385	343	31
32LVSS5-14/5-61.5-□		900	493	451	33
32LVSS5-16/5-61.5-□		954	547	505	33
32LVSS5-20/5-61.5-□		1062	655	613	35
32LVSS5-6/6-62.2-□		684	277	235	34
32LVSS5-8/6-62.2-□		738	331	289	34
32LVSS5-10/6-62.2-□		792	385	343	35
32LVSS5-14/6-62.2-□		900	493	451	36
32LVSS5-16/6-62.2-□		954	547	505	37
32LVSS5-20/6-62.2-□		1062	655	613	38
32LVSS5-7/7-62.2-□		711	304	262	34
32LVSS5-10/7-62.2-□		792	385	343	35
32LVSS5-14/7-62.2-□		900	493	451	36
32LVSS5-16/7-62.2-□		954	547	505	37
32LVSS5-20/7-62.2-□		1062	655	613	38
32LVSS5-8/8-62.2-□		738	331	289	34
32LVSS5-10/8-62.2-□		792	385	343	35
32LVSS5-14/8-62.2-□		900	493	451	36
32LVSS5-16/8-62.2-□		954	547	505	37
32LVSS5-20/8-62.2-□		1062	655	613	38
32LVSS5-10/10-63.0-□		815	385	343	42
32LVSS5-14/10-63.0-□		923	493	451	43
32LVSS5-16/10-63.0-□		977	547	505	44
32LVSS5-20/10-63.0-□		1085	655	613	45
32LVSS5-12/12-63.0-□		869	439	397	43
32LVSS5-14/12-63.0-□		923	493	451	43
32LVSS5-16/12-63.0-□	977	547	505	44	
32LVSS5-20/12-63.0-□	1085	655	613	45	
32LVSS5-24/12-63.0-□	1193	763	721	46	
32LVSS5-14/14-64.0-□	930	493	451	49	
32LVSS5-16/14-64.0-□	984	547	505	50	
32LVSS5-20/14-64.0-□	1092	655	613	51	
32LVSS5-24/14-64.0-□	1200	763	721	52	
32LVSS5-29/14-64.0-□	1335	898	856	54	
32LVSS5-16/16-64.0-□	984	547	505	50	
32LVSS5-20/16-64.0-□	1092	655	613	51	
32LVSS5-24/16-64.0-□	1200	763	721	52	
32LVSS5-29/16-64.0-□	1335	898	856	54	
32LVSS5-32/16-64.0-□	1416	979	937	55	
32LVSS5-20/20-65.5-□	1155	655	613	79	
32LVSS5-24/20-65.5-□	1263	763	721	80	
32LVSS5-29/20-65.5-□	1398	898	856	81	
32LVSS5-32/20-65.5-□	1479	979	937	82	
32LVSS5-22/22-65.5-□	1209	709	667	79	
32LVSS5-24/22-65.5-□	1263	763	721	80	
32LVSS5-29/22-65.5-□	1398	898	856	81	
32LVSS5-32/22-65.5-□	1479	979	937	82	
32LVSS5-24/24-67.5-□	1303	763	721	87	
32LVSS5-29/24-67.5-□	1438	898	856	88	
32LVSS5-32/24-67.5-□	1519	979	937	89	

Note 1) "□" in pump type can be any one of -e/-KS/-7W.

Assembly drawing

● Discharge diameter: 50mm

Fig.1

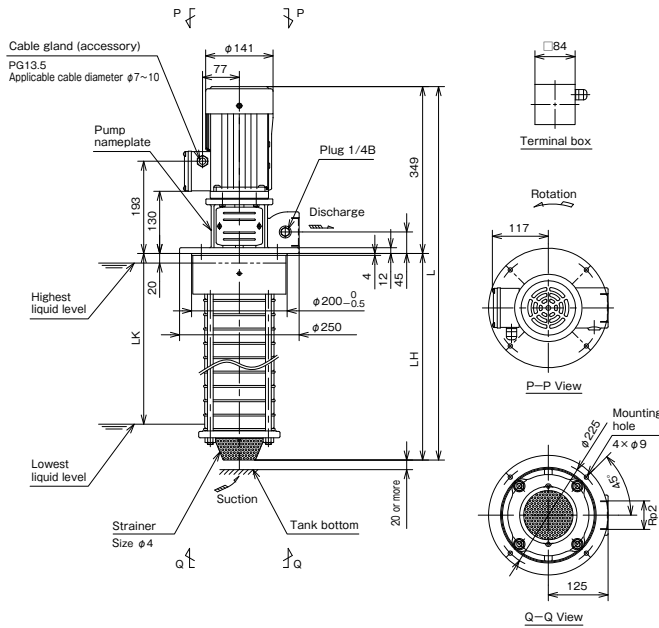
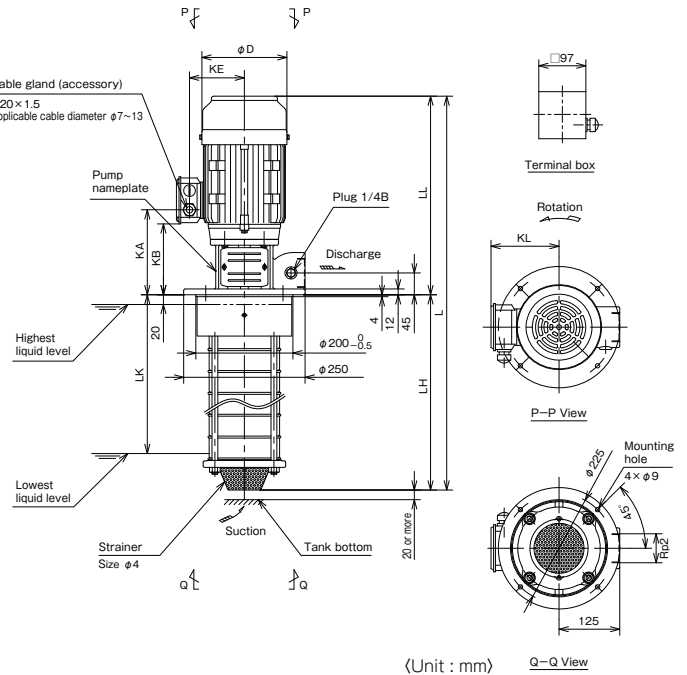

Fig.2



※ Output 0.75kW

(Unit : mm)

Output kW	D	KA	KB	KE	KL	LL
1.1	175	169	140	113	140	403
1.5/2.2	175	175	146	113	140	409
3.0	196	186	156	125	152	442
4.0	219	190	161	134	161	449

Fig.3

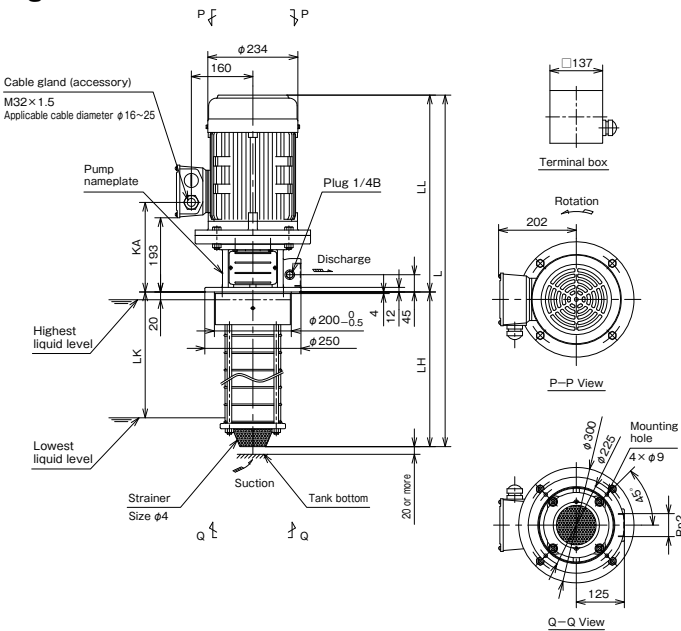
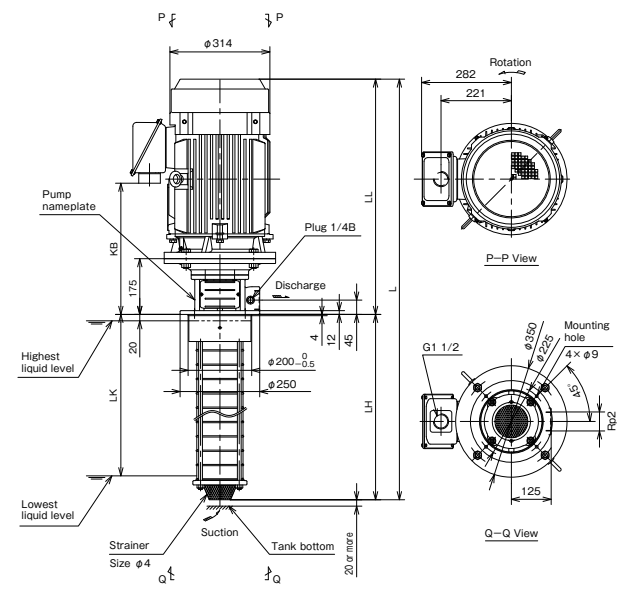

Fig.4



(Unit : mm)

Output kW	LL	KA
5.5	512	233
7.5	552	234

(Unit : mm)

Output kW	KB	LL
11/15	382	689
18.5	412	719

■ Dimensions

●Discharge diameter :50mm, Nominal flow rate : 10m³/h

50Hz

(Unit : mm)

Type	Fig.	L	LH	LK	Approx. mass(kg)	
50LVSS10-5/2-5.75-e	1	631	282	207	30	
50LVSS10-6/2-5.75-e		661	312	237	30	
50LVSS10-8/2-5.75-e		721	372	297	32	
50LVSS10-10/2-5.75-e		781	432	357	33	
50LVSS10-12/2-5.75-e		841	492	417	34	
50LVSS10-14/2-5.75-e		901	552	477	36	
50LVSS10-16/2-5.75-e		961	612	537	37	
50LVSS10-18/2-5.75-e		1021	672	597	38	
50LVSS10-20/2-5.75-e		1081	732	657	40	
50LVSS10-22/2-5.75-e		1141	792	717	41	
50LVSS10-5/3-51.1-e		2	685	282	207	34.5
50LVSS10-6/3-51.1-e	715		312	237	35.5	
50LVSS10-8/3-51.1-e	775		372	297	36.5	
50LVSS10-10/3-51.1-e	835		432	357	37.5	
50LVSS10-12/3-51.1-e	895		492	417	39.5	
50LVSS10-14/3-51.1-e	955		552	477	40.5	
50LVSS10-16/3-51.1-e	1015		612	537	41.5	
50LVSS10-18/3-51.1-e	1075		672	597	42.5	
50LVSS10-20/3-51.1-e	1135		732	657	44.5	
50LVSS10-22/3-51.1-e	1195		792	717	45.5	
50LVSS10-5/4-51.5-e	691		282	207	38.5	
50LVSS10-6/4-51.5-e	721		312	237	38.5	
50LVSS10-8/4-51.5-e	781		372	297	40.5	
50LVSS10-10/4-51.5-e	841		432	357	41.5	
50LVSS10-12/4-51.5-e	901		492	417	42.5	
50LVSS10-14/4-51.5-e	961		552	477	44.5	
50LVSS10-16/4-51.5-e	1021		612	537	45.5	
50LVSS10-18/4-51.5-e	1081		672	597	46.5	
50LVSS10-20/4-51.5-e	1141		732	657	48.5	
50LVSS10-22/4-51.5-e	1201		792	717	49.5	
50LVSS10-5/5-52.2-e	2		691	282	207	41.5
50LVSS10-6/5-52.2-e			721	312	237	42.5
50LVSS10-8/5-52.2-e			781	372	297	43.5
50LVSS10-10/5-52.2-e			841	432	357	45.5
50LVSS10-12/5-52.2-e			901	492	417	46.5
50LVSS10-14/5-52.2-e			961	552	477	47.5
50LVSS10-16/5-52.2-e			1021	612	537	49.5
50LVSS10-18/5-52.2-e			1081	672	597	50.5
50LVSS10-20/5-52.2-e			1141	732	657	51.5
50LVSS10-22/5-52.2-e			1201	792	717	53.5
50LVSS10-6/6-52.2-e			721	312	237	42.5
50LVSS10-8/6-52.2-e			781	372	297	43.5
50LVSS10-10/6-52.2-e			841	432	357	45.5
50LVSS10-12/6-52.2-e			901	492	417	46.5
50LVSS10-14/6-52.2-e		961	552	477	47.5	
50LVSS10-16/6-52.2-e		1021	612	537	49.5	
50LVSS10-18/6-52.2-e		1081	672	597	50.5	
50LVSS10-20/6-52.2-e		1141	732	657	51.5	
50LVSS10-22/6-52.2-e		1201	792	717	53.5	

(Unit : mm)

Type	Fig.	L	LH	LK	Approx. mass(kg)	
50LVSS10-8/8-53.0-e	2	814	372	297	52	
50LVSS10-10/8-53.0-e		874	432	357	53	
50LVSS10-12/8-53.0-e		934	492	417	54	
50LVSS10-14/8-53.0-e		994	552	477	56	
50LVSS10-16/8-53.0-e		1054	612	537	57	
50LVSS10-18/8-53.0-e		1114	672	597	58	
50LVSS10-20/8-53.0-e		1174	732	657	60	
50LVSS10-22/8-53.0-e		1234	792	717	61	
50LVSS10-10/10-54.0-e		2	881	432	357	59
50LVSS10-12/10-54.0-e			941	492	417	60
50LVSS10-14/10-54.0-e			1001	552	477	61
50LVSS10-16/10-54.0-e			1061	612	537	63
50LVSS10-18/10-54.0-e			1121	672	597	64
50LVSS10-20/10-54.0-e			1181	732	657	65
50LVSS10-22/10-54.0-e			1241	792	717	67
50LVSS10-12/12-54.0-e			941	492	417	60
50LVSS10-14/12-54.0-e			1001	552	477	61
50LVSS10-16/12-54.0-e			1061	612	537	63
50LVSS10-18/12-54.0-e	1121		672	597	64	
50LVSS10-20/12-54.0-e	1181		732	657	65	
50LVSS10-22/12-54.0-e	1241		792	717	67	
50LVSS10-14/14-55.5-e	3		1064	552	477	89
50LVSS10-16/14-55.5-e			1124	612	537	90
50LVSS10-18/14-55.5-e			1184	672	597	92
50LVSS10-20/14-55.5-e			1244	732	657	93
50LVSS10-22/14-55.5-e			1304	792	717	94
50LVSS10-16/16-55.5-e		1124	612	537	91	
50LVSS10-18/16-55.5-e		1184	672	597	92	
50LVSS10-20/16-55.5-e		1244	732	657	93	
50LVSS10-22/16-55.5-e		1304	792	717	94	
50LVSS10-18/18-57.5-e		1224	672	597	99	
50LVSS10-20/18-57.5-e		1284	732	657	100	
50LVSS10-22/18-57.5-e		1344	792	717	101	
50LVSS10-20/20-57.5-e		1284	732	657	100	
50LVSS10-22/20-57.5-e		1344	792	717	101	
50LVSS10-22/22-57.5-e		1344	792	717	102	

●Discharge diameter :50mm, Nominal flow rate : 10m³/h

60Hz

(Unit : mm)

(Unit : mm)

Type	Fig.	L	LH	LK	Approx. mass(kg)
50LVSS10-5/1-6.75-□	1	631	282	207	30
50LVSS10-6/1-6.75-□		661	312	237	30
50LVSS10-8/1-6.75-□		721	372	297	32
50LVSS10-10/1-6.75-□		781	432	357	33
50LVSS10-12/1-6.75-□		841	492	417	34
50LVSS10-5/2-61.5-□	2	691	282	207	38.5
50LVSS10-6/2-61.5-□		721	312	237	38.5
50LVSS10-8/2-61.5-□		781	372	297	40.5
50LVSS10-10/2-61.5-□		841	432	357	41.5
50LVSS10-12/2-61.5-□		901	492	417	42.5
50LVSS10-14/2-61.5-□		961	552	477	44.5
50LVSS10-16/2-61.5-□		1021	612	537	45.5
50LVSS10-18/2-61.5-□		1081	672	597	46.5
50LVSS10-20/2-61.5-□		1141	732	657	48.5
50LVSS10-22/2-61.5-□		1201	792	717	49.5
50LVSS10-5/3-62.2-□		691	282	207	41.5
50LVSS10-6/3-62.2-□		721	312	237	42.5
50LVSS10-8/3-62.2-□		781	372	297	43.5
50LVSS10-10/3-62.2-□		841	432	357	44.5
50LVSS10-12/3-62.2-□		901	492	417	46.5
50LVSS10-14/3-62.2-□		961	552	477	47.5
50LVSS10-16/3-62.2-□		1021	612	537	48.5
50LVSS10-18/3-62.2-□		1081	672	597	50.5
50LVSS10-20/3-62.2-□		1141	732	657	51.5
50LVSS10-22/3-62.2-□		1201	792	717	52.5
50LVSS10-5/4-63.0-□		724	282	207	49
50LVSS10-6/4-63.0-□		754	312	237	50
50LVSS10-8/4-63.0-□		814	372	297	51
50LVSS10-10/4-63.0-□		874	432	357	53
50LVSS10-12/4-63.0-□		934	492	417	54
50LVSS10-14/4-63.0-□		994	552	477	55
50LVSS10-16/4-63.0-□		1054	612	537	57
50LVSS10-18/4-63.0-□		1114	672	597	58
50LVSS10-20/4-63.0-□		1174	732	657	59
50LVSS10-22/4-63.0-□		1234	792	717	61
50LVSS10-5/5-63.0-□		724	282	207	49
50LVSS10-6/5-63.0-□		754	312	237	50
50LVSS10-8/5-63.0-□	814	372	297	51	
50LVSS10-10/5-63.0-□	874	432	357	53	
50LVSS10-12/5-63.0-□	934	492	417	54	
50LVSS10-14/5-63.0-□	994	552	477	55	
50LVSS10-16/5-63.0-□	1054	612	537	57	
50LVSS10-18/5-63.0-□	1114	672	597	58	
50LVSS10-20/5-63.0-□	1174	732	657	59	
50LVSS10-22/5-63.0-□	1234	792	717	61	
50LVSS10-6/6-64.0-□	761	312	237	56	
50LVSS10-8/6-64.0-□	821	372	297	57	
50LVSS10-10/6-64.0-□	881	432	357	58	
50LVSS10-12/6-64.0-□	941	492	417	60	
50LVSS10-14/6-64.0-□	1001	552	477	61	
50LVSS10-16/6-64.0-□	1061	612	537	62	
50LVSS10-18/6-64.0-□	1121	672	597	64	
50LVSS10-20/6-64.0-□	1181	732	657	65	
50LVSS10-22/6-64.0-□	1241	792	717	66	

Note 1) "□" in pump type can be any one of -e/-KS/-7W.

Type	Fig.	L	LH	LK	Approx. mass(kg)	
50LVSS10-8/8-65.5-□	3	884	372	297	84	
50LVSS10-10/8-65.5-□		944	432	357	86	
50LVSS10-12/8-65.5-□		1004	492	417	87	
50LVSS10-14/8-65.5-□		1064	552	477	88	
50LVSS10-16/8-65.5-□		1124	612	537	90	
50LVSS10-18/8-65.5-□		1184	672	597	91	
50LVSS10-20/8-65.5-□		1244	732	657	92	
50LVSS10-22/8-65.5-□		1304	792	717	94	
50LVSS10-9/9-65.5-□		914	402	327	85	
50LVSS10-12/9-65.5-□		1004	492	417	87	
50LVSS10-14/9-65.5-□		1064	552	477	89	
50LVSS10-16/9-65.5-□		1124	612	537	90	
50LVSS10-18/9-65.5-□		1184	672	597	91	
50LVSS10-20/9-65.5-□		1244	732	657	92	
50LVSS10-22/9-65.5-□		1304	792	717	94	
50LVSS10-10/10-67.5-□		984	432	357	93	
50LVSS10-12/10-67.5-□		1044	492	417	94	
50LVSS10-14/10-67.5-□		1104	552	477	95	
50LVSS10-16/10-67.5-□		1164	612	537	97	
50LVSS10-18/10-67.5-□		1224	672	597	98	
50LVSS10-20/10-67.5-□		1284	732	657	99	
50LVSS10-22/10-67.5-□		1344	792	717	101	
50LVSS10-12/12-67.5-□		1044	492	417	94	
50LVSS10-14/12-67.5-□		1104	552	477	95	
50LVSS10-16/12-67.5-□		1164	612	537	97	
50LVSS10-18/12-67.5-□		1224	672	597	98	
50LVSS10-20/12-67.5-□		1284	732	657	99	
50LVSS10-22/12-67.5-□		1344	792	717	101	
50LVSS10-14/14-611-e		4	1241	552	477	170
50LVSS10-16/14-611-e			1301	612	537	171
50LVSS10-18/14-611-e			1361	672	597	173
50LVSS10-20/14-611-e			1421	732	657	174
50LVSS10-22/14-611-e	1481		792	717	175	
50LVSS10-16/16-611-e	1301		612	537	171	
50LVSS10-18/16-611-e	1361		672	597	173	
50LVSS10-20/16-611-e	1421		732	657	174	
50LVSS10-22/16-611-e	1481		792	717	175	
50LVSS10-18/18-611-e	1361		672	597	173	
50LVSS10-20/18-611-e	1421		732	657	174	
50LVSS10-22/18-611-e	1481		792	717	176	

Note 1) "□" in pump type can be any one of -e/-KS/-7W.

●Discharge diameter : 50mm, Nominal flow rate : 15m³/h

50Hz

(Unit : mm)

Type	Fig.	L	LH	LK	Approx. mass(kg)
50LVSS15-3/1-51.1-e	2	670	267	192	33.5
50LVSS15-4/1-51.1-e		715	312	237	34.5
50LVSS15-5/1-51.1-e		760	357	282	35.5
50LVSS15-6/1-51.1-e		805	402	327	36.5
50LVSS15-7/1-51.1-e		850	447	372	37.5
50LVSS15-8/1-51.1-e		895	492	417	38.5
50LVSS15-3/2-52.2-e		676	267	192	41.5
50LVSS15-4/2-52.2-e		721	312	237	41.5
50LVSS15-5/2-52.2-e		766	357	282	42.5
50LVSS15-6/2-52.2-e		811	402	327	43.5
50LVSS15-7/2-52.2-e		856	447	372	44.5
50LVSS15-8/2-52.2-e		901	492	417	45.5
50LVSS15-10/2-52.2-e		991	582	507	46.5
50LVSS15-12/2-52.2-e		1081	672	597	48.5
50LVSS15-14/2-52.2-e		1171	762	687	50.5
50LVSS15-3/3-53.0-e		709	267	192	49
50LVSS15-4/3-53.0-e		754	312	237	49
50LVSS15-5/3-53.0-e		799	357	282	50
50LVSS15-6/3-53.0-e		844	402	327	51
50LVSS15-7/3-53.0-e		889	447	372	52
50LVSS15-8/3-53.0-e		934	492	417	53
50LVSS15-10/3-53.0-e		1024	582	507	55
50LVSS15-12/3-53.0-e		1114	672	597	56
50LVSS15-14/3-53.0-e		1204	762	687	58
50LVSS15-17/3-53.0-e		1339	897	822	60
50LVSS15-4/4-54.0-e		761	312	237	55
50LVSS15-5/4-54.0-e		806	357	282	56
50LVSS15-6/4-54.0-e		851	402	327	57
50LVSS15-7/4-54.0-e	896	447	372	58	
50LVSS15-8/4-54.0-e	941	492	417	59	
50LVSS15-10/4-54.0-e	1031	582	507	60	
50LVSS15-12/4-54.0-e	1121	672	597	62	
50LVSS15-14/4-54.0-e	1211	762	687	64	
50LVSS15-17/4-54.0-e	1346	897	822	66	
50LVSS15-5/5-54.0-e	806	357	282	56	
50LVSS15-6/5-54.0-e	851	402	327	57	
50LVSS15-7/5-54.0-e	896	447	372	58	
50LVSS15-8/5-54.0-e	941	492	417	59	
50LVSS15-10/5-54.0-e	1031	582	507	60	
50LVSS15-12/5-54.0-e	1121	672	597	62	
50LVSS15-14/5-54.0-e	1211	762	687	64	
50LVSS15-17/5-54.0-e	1346	897	822	66	
50LVSS15-6/6-55.5-e	914	402	327	85	
50LVSS15-7/6-55.5-e	959	447	372	85	
50LVSS15-8/6-55.5-e	1004	492	417	86	
50LVSS15-10/6-55.5-e	1094	582	507	88	
50LVSS15-12/6-55.5-e	1184	672	597	90	
50LVSS15-14/6-55.5-e	1274	762	687	91	
50LVSS15-17/6-55.5-e	1409	897	822	94	
50LVSS15-7/7-55.5-e	959	447	372	86	
50LVSS15-8/7-55.5-e	1004	492	417	86	
50LVSS15-10/7-55.5-e	1094	582	507	88	
50LVSS15-12/7-55.5-e	1184	672	597	90	
50LVSS15-14/7-55.5-e	1274	762	687	91	
50LVSS15-17/7-55.5-e	1409	897	822	94	
50LVSS15-8/8-57.5-e	1044	492	417	93	
50LVSS15-10/8-57.5-e	1134	582	507	95	
50LVSS15-12/8-57.5-e	1224	672	597	97	
50LVSS15-14/8-57.5-e	1314	762	687	98	
50LVSS15-17/8-57.5-e	1449	897	822	101	
50LVSS15-9/9-57.5-e	1089	537	462	94	
50LVSS15-12/9-57.5-e	1224	672	597	97	
50LVSS15-14/9-57.5-e	1314	762	687	98	
50LVSS15-17/9-57.5-e	1449	897	822	101	
50LVSS15-10/10-511-e	1271	582	507	170	
50LVSS15-12/10-511-e	1361	672	597	171	
50LVSS15-14/10-511-e	1451	762	687	173	
50LVSS15-17/10-511-e	1586	897	822	175	
50LVSS15-12/12-511-e	1361	672	597	172	
50LVSS15-14/12-511-e	1451	762	687	173	
50LVSS15-17/12-511-e	1586	897	822	176	
50LVSS15-14/14-511-e	1451	762	687	174	
50LVSS15-17/14-511-e	1586	897	822	176	
50LVSS15-17/17-515-e	1586	897	822	188	

60Hz

(Unit : mm)

Type	Fig.	L	LH	LK	Approx. mass(kg)
50LVSS15-3/1-61.5-□	2	676	267	192	37.5
50LVSS15-4/1-61.5-□		721	312	237	38.5
50LVSS15-5/1-61.5-□		766	357	282	39.5
50LVSS15-6/1-61.5-□		811	402	327	40.5
50LVSS15-7/1-61.5-□		856	447	372	40.5
50LVSS15-8/1-61.5-□		901	492	417	41.5
50LVSS15-10/1-61.5-□		991	582	507	43.5
50LVSS15-3/2-63.0-□		709	267	192	49
50LVSS15-4/2-63.0-□		754	312	237	49
50LVSS15-5/2-63.0-□		799	357	282	50
50LVSS15-6/2-63.0-□		844	402	327	51
50LVSS15-7/2-63.0-□		889	447	372	52
50LVSS15-8/2-63.0-□		934	492	417	53
50LVSS15-10/2-63.0-□		1024	582	507	55
50LVSS15-12/2-63.0-□		1114	672	597	56
50LVSS15-14/2-63.0-□		1204	762	687	58
50LVSS15-17/2-63.0-□		1339	897	822	61
50LVSS15-3/3-64.0-□		716	267	192	54
50LVSS15-4/3-64.0-□		761	312	237	55
50LVSS15-5/3-64.0-□		806	357	282	56
50LVSS15-6/3-64.0-□		851	402	327	57
50LVSS15-7/3-64.0-□		896	447	372	57
50LVSS15-8/3-64.0-□		941	492	417	58
50LVSS15-10/3-64.0-□		1031	582	507	60
50LVSS15-12/3-64.0-□		1121	672	597	62
50LVSS15-14/3-64.0-□		1211	762	687	63
50LVSS15-17/3-64.0-□		1346	897	822	66
50LVSS15-4/4-65.5-□		824	312	237	82
50LVSS15-5/4-65.5-□	869	357	282	83	
50LVSS15-6/4-65.5-□	914	402	327	84	
50LVSS15-7/4-65.5-□	959	447	372	85	
50LVSS15-8/4-65.5-□	1004	492	417	86	
50LVSS15-10/4-65.5-□	1094	582	507	88	
50LVSS15-12/4-65.5-□	1184	672	597	89	
50LVSS15-14/4-65.5-□	1274	762	687	91	
50LVSS15-17/4-65.5-□	1409	897	822	93	
50LVSS15-5/5-67.5-□	909	357	282	90	
50LVSS15-6/5-67.5-□	954	402	327	91	
50LVSS15-7/5-67.5-□	999	447	372	92	
50LVSS15-8/5-67.5-□	1044	492	417	93	
50LVSS15-10/5-67.5-□	1134	582	507	94	
50LVSS15-12/5-67.5-□	1224	672	597	96	
50LVSS15-14/5-67.5-□	1314	762	687	98	
50LVSS15-17/5-67.5-□	1449	897	822	100	
50LVSS15-6/6-611-e	1091	402	327	165	
50LVSS15-7/6-611-e	1136	447	372	166	
50LVSS15-8/6-611-e	1181	492	417	167	
50LVSS15-10/6-611-e	1271	582	507	169	
50LVSS15-12/6-611-e	1361	672	597	170	
50LVSS15-14/6-611-e	1451	762	687	172	
50LVSS15-17/6-611-e	1586	897	822	175	
50LVSS15-7/7-611-e	1136	447	372	166	
50LVSS15-8/7-611-e	1181	492	417	167	
50LVSS15-10/7-611-e	1271	582	507	169	
50LVSS15-12/7-611-e	1361	672	597	171	
50LVSS15-14/7-611-e	1451	762	687	172	
50LVSS15-17/7-611-e	1586	897	822	175	
50LVSS15-8/8-611-e	1181	492	417	168	
50LVSS15-10/8-611-e	1271	582	507	169	
50LVSS15-12/8-611-e	1361	672	597	171	
50LVSS15-14/8-611-e	1451	762	687	173	
50LVSS15-17/8-611-e	1586	897	822	175	
50LVSS15-10/10-615-e	1271	582	507	181	
50LVSS15-12/10-615-e	1361	672	597	182	
50LVSS15-14/10-615-e	1451	762	687	184	
50LVSS15-17/10-615-e	1586	897	822	186	
50LVSS15-12/12-618-e	1391	672	597	199	
50LVSS15-14/12-618-e	1481	762	687	200	
50LVSS15-17/12-618-e	1616	897	822	203	

Note 1) "□" in pump type can be any one of -e/-KS/-7W.

●Discharge diameter : 50mm, Nominal flow rate : 20m³/h

50Hz

(Unit : mm)

Type	Fig.	L	LH	LK	Approx. mass(kg)
50LVSS20-3/1-51.1-e	2	670	267	192	33.5
50LVSS20-4/1-51.1-e		715	312	237	34.5
50LVSS20-5/1-51.1-e		760	357	282	35.5
50LVSS20-6/1-51.1-e		805	402	327	36.5
50LVSS20-3/2-52.2-e		676	267	192	41.5
50LVSS20-4/2-52.2-e		721	312	237	41.5
50LVSS20-5/2-52.2-e		766	357	282	42.5
50LVSS20-6/2-52.2-e		811	402	327	43.5
50LVSS20-7/2-52.2-e		856	447	372	44.5
50LVSS20-8/2-52.2-e		901	492	417	45.5
50LVSS20-10/2-52.2-e		991	582	507	46.5
50LVSS20-12/2-52.2-e		1081	672	597	48.5
50LVSS20-3/3-54.0-e		716	267	192	54
50LVSS20-4/3-54.0-e		761	312	237	55
50LVSS20-5/3-54.0-e		806	357	282	56
50LVSS20-6/3-54.0-e		851	402	327	57
50LVSS20-7/3-54.0-e		896	447	372	57
50LVSS20-8/3-54.0-e		941	492	417	58
50LVSS20-10/3-54.0-e		1031	582	507	60
50LVSS20-12/3-54.0-e		1121	672	597	62
50LVSS20-14/3-54.0-e	1211	762	687	63	
50LVSS20-17/3-54.0-e	1346	897	822	66	
50LVSS20-4/4-55.5-e	3	824	312	237	82
50LVSS20-5/4-55.5-e		869	357	282	83
50LVSS20-6/4-55.5-e		914	402	327	84
50LVSS20-7/4-55.5-e		959	447	372	85
50LVSS20-8/4-55.5-e		1004	492	417	86
50LVSS20-10/4-55.5-e		1094	582	507	88
50LVSS20-12/4-55.5-e		1184	672	597	89
50LVSS20-14/4-55.5-e		1274	762	687	91
50LVSS20-17/4-55.5-e		1409	897	822	93
50LVSS20-5/5-55.5-e		869	357	282	84
50LVSS20-6/5-55.5-e		914	402	327	84
50LVSS20-7/5-55.5-e		959	447	372	85
50LVSS20-8/5-55.5-e		1004	492	417	86
50LVSS20-10/5-55.5-e		1094	582	507	88
50LVSS20-12/5-55.5-e		1184	672	597	89
50LVSS20-14/5-55.5-e		1274	762	687	91
50LVSS20-17/5-55.5-e		1409	897	822	94
50LVSS20-6/6-57.5-e		954	402	327	91
50LVSS20-7/6-57.5-e		999	447	372	92
50LVSS20-8/6-57.5-e		1044	492	417	93
50LVSS20-10/6-57.5-e	1134	582	507	95	
50LVSS20-12/6-57.5-e	1224	672	597	96	
50LVSS20-14/6-57.5-e	1314	762	687	98	
50LVSS20-17/6-57.5-e	1449	897	822	100	
50LVSS20-7/7-57.5-e	999	447	372	92	
50LVSS20-8/7-57.5-e	1044	492	417	93	
50LVSS20-10/7-57.5-e	1134	582	507	95	
50LVSS20-12/7-57.5-e	1224	672	597	96	
50LVSS20-14/7-57.5-e	1314	762	687	98	
50LVSS20-17/7-57.5-e	1449	897	822	101	
50LVSS20-8/8-511-e	4	1181	492	417	168
50LVSS20-10/8-511-e		1271	582	507	169
50LVSS20-12/8-511-e		1361	672	597	171
50LVSS20-14/8-511-e		1451	762	687	173
50LVSS20-17/8-511-e		1586	897	822	175
50LVSS20-10/10-511-e		1271	582	507	169
50LVSS20-12/10-511-e		1361	672	597	171
50LVSS20-14/10-511-e		1451	762	687	173
50LVSS20-17/10-511-e		1586	897	822	175
50LVSS20-12/12-515-e		1361	672	597	183
50LVSS20-14/12-515-e		1451	762	687	184
50LVSS20-17/12-515-e		1586	897	822	187
50LVSS20-14/14-515-e		1451	762	687	184
50LVSS20-17/14-515-e		1586	897	822	187
50LVSS20-17/17-518-e		1616	897	822	204

60Hz

(Unit : mm)

Type	Fig.	L	LH	LK	Approx. mass(kg)
50LVSS20-3/1-62.2-□	2	676	267	192	41.5
50LVSS20-4/1-62.2-□		721	312	237	41.5
50LVSS20-5/1-62.2-□		766	357	282	42.5
50LVSS20-6/1-62.2-□		811	402	327	43.5
50LVSS20-7/1-62.2-□		856	447	372	44.5
50LVSS20-3/2-64.0-□		716	267	192	54
50LVSS20-4/2-64.0-□		761	312	237	55
50LVSS20-5/2-64.0-□		806	357	282	56
50LVSS20-6/2-64.0-□		851	402	327	57
50LVSS20-7/2-64.0-□		896	447	372	57
50LVSS20-8/2-64.0-□		941	492	417	58
50LVSS20-10/2-64.0-□		1031	582	507	60
50LVSS20-12/2-64.0-□		1121	672	597	62
50LVSS20-3/3-65.5-□		779	267	192	81
50LVSS20-4/3-65.5-□		824	312	237	82
50LVSS20-5/3-65.5-□		869	357	282	83
50LVSS20-6/3-65.5-□		914	402	327	84
50LVSS20-7/3-65.5-□		959	447	372	85
50LVSS20-8/3-65.5-□		1004	492	417	86
50LVSS20-10/3-65.5-□		1094	582	507	87
50LVSS20-12/3-65.5-□	1184	672	597	89	
50LVSS20-14/3-65.5-□	1274	762	687	91	
50LVSS20-17/3-65.5-□	1409	897	822	93	
50LVSS20-4/4-67.5-□	3	864	312	237	89
50LVSS20-5/4-67.5-□		909	357	282	90
50LVSS20-6/4-67.5-□		954	402	327	91
50LVSS20-7/4-67.5-□		999	447	372	92
50LVSS20-8/4-67.5-□		1044	492	417	92
50LVSS20-10/4-67.5-□		1134	582	507	94
50LVSS20-12/4-67.5-□		1224	672	597	96
50LVSS20-14/4-67.5-□		1314	762	687	97
50LVSS20-17/4-67.5-□		1449	897	822	100
50LVSS20-5/5-611-e		1046	357	282	164
50LVSS20-6/5-611-e		1091	402	327	165
50LVSS20-7/5-611-e		1136	447	372	166
50LVSS20-8/5-611-e		1181	492	417	167
50LVSS20-10/5-611-e		1271	582	507	169
50LVSS20-12/5-611-e		1361	672	597	170
50LVSS20-14/5-611-e		1451	762	687	172
50LVSS20-17/5-611-e		1586	897	822	174
50LVSS20-6/6-611-e		1091	402	327	165
50LVSS20-7/6-611-e		1136	447	372	166
50LVSS20-8/6-611-e		1181	492	417	167
50LVSS20-10/6-611-e	1271	582	507	169	
50LVSS20-12/6-611-e	1361	672	597	170	
50LVSS20-14/6-611-e	1451	762	687	172	
50LVSS20-17/6-611-e	1586	897	822	175	
50LVSS20-7/7-615-e	4	1136	447	372	166
50LVSS20-8/7-615-e		1181	492	417	167
50LVSS20-10/7-615-e		1271	582	507	169
50LVSS20-12/7-615-e		1361	672	597	170
50LVSS20-14/7-615-e		1451	762	687	172
50LVSS20-17/7-615-e		1586	897	822	175
50LVSS20-8/8-615-e		1181	492	417	167
50LVSS20-10/8-615-e		1271	582	507	169
50LVSS20-12/8-615-e		1361	672	597	170
50LVSS20-14/8-615-e		1451	762	687	172
50LVSS20-17/8-615-e		1586	897	822	175
50LVSS20-10/10-618-e		1301	582	507	197
50LVSS20-12/10-618-e		1391	672	597	198
50LVSS20-14/10-618-e		1481	762	687	200
50LVSS20-17/10-618-e		1616	897	822	202

Note 1) "□" in pump type can be any one of -e/-KS/-7W.

■ Detailed drawing of the terminal box

■ Assembly drawing (-e/-KS type)

● Output 0.75kW

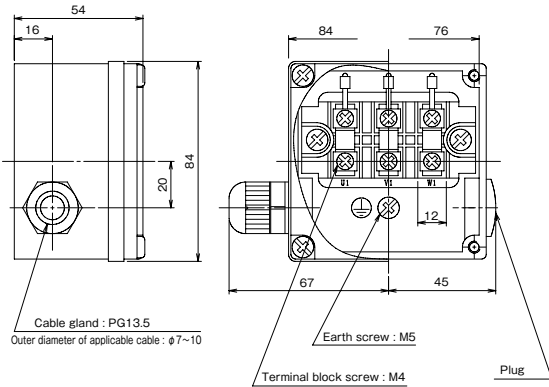

■ Connection diagram

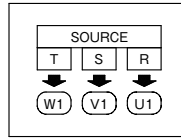

● Output 1.1-4.0 kW

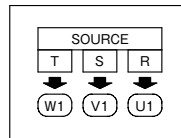
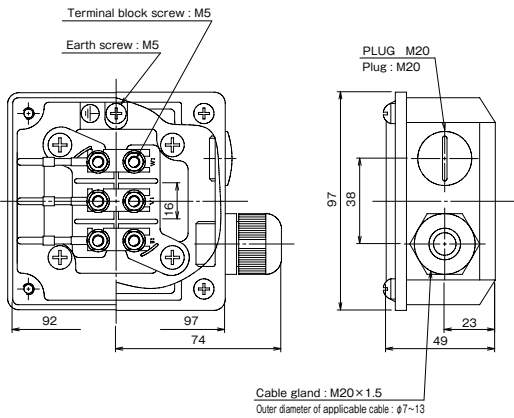

● Output 5.5, 7.5 kW

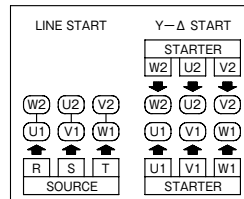
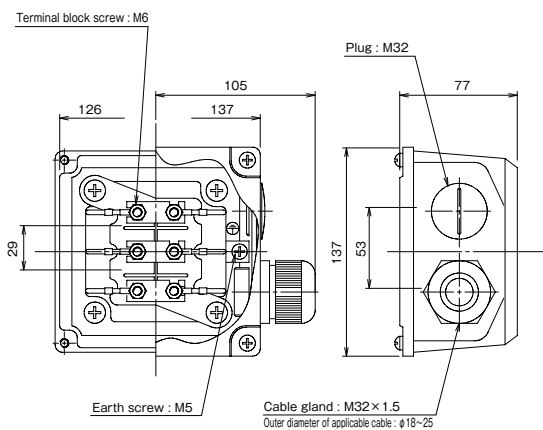

● Output 11-18.5 kW (-e type)

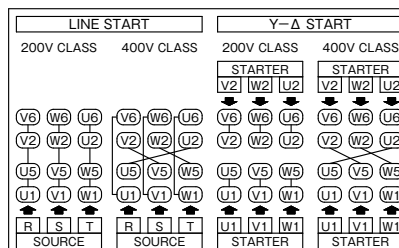
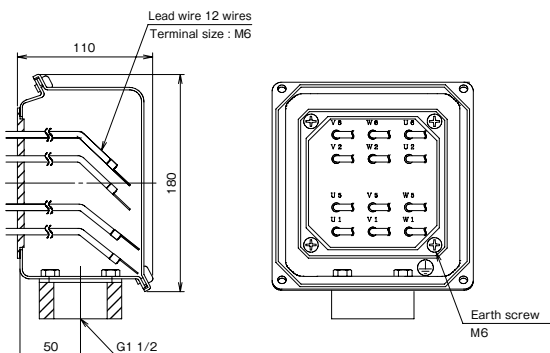

Assembly drawing (-7W type)

Output 0.75kW

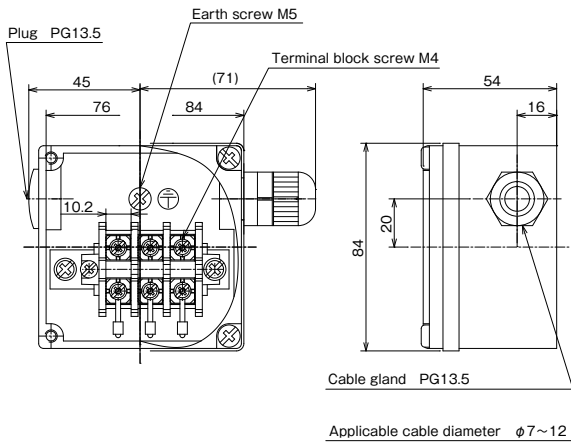

Connection diagram

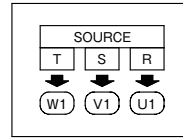

Output 1.1-4.0kW

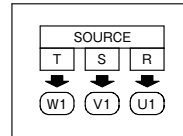
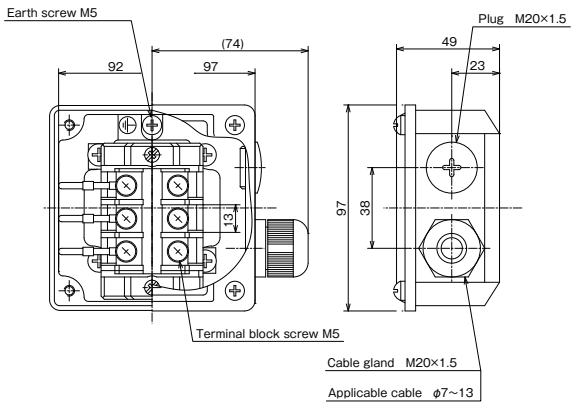

Output 5.5kW, 7.5kW

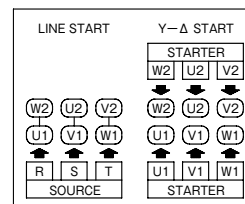
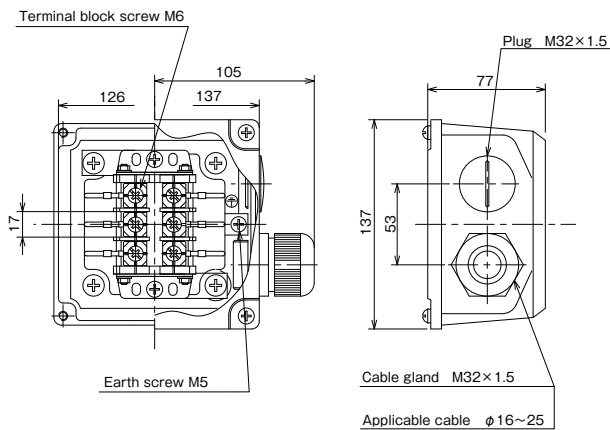

Sectional drawing

●32LVSS-e

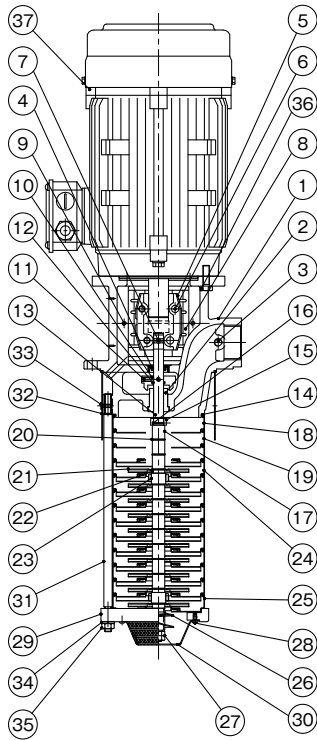

No.	Part name	Material
1	Discharge casing	SCS13
2	Bushing	SUS430
3	Plug	SUS304
4	Oil seal	NBR
5	Coupling	FC0205
6	Hexagon socket head bolt	SCM435
7	Shaft pin	SUS316
8	Coupling cover	SUS304
9	Cross-recessed pan head screw	SUS304
10	Oil thrower	SUS304
11	Set screw	SUS304
12	O-ring	FKM
13	Main shaft	SUS420J2
14	Gasket	—
15	Shaft bushing	SUS304
16	Shaft ring	SUS316
17	Sleeve	SUS304
18	Intermediate casing (Final stage)	SUS304
19	Intermediate casing	SUS304
20	Shim	SUS304
21	Impeller	SUS304
22	Baffle	SUS304
23	Bearings	SiC
24	Bearing casing	SUS304+SiC
25	Intermediate casing (First stage)	SUS304
26	Screw	SUS304
27	Hard locknut	SUS304
28	Cross-recessed pan head screw	SUS304
29	Suction casing	SCS14A
30	Strainer	SUS304
31	Through bolt	SUS304
32	Outer sleeve	SUS304
33	Cross-recessed flat head screw	SUS304
34	Spring washer	SUS304
35	Hexagon nut	SUS304
36	Hexagon bolt	SUS304
37	Motor	—

Note 1) The materials in the table above are equivalents.
Note 2) Structure and other details are subject to change without notice.

●50LVSS-e

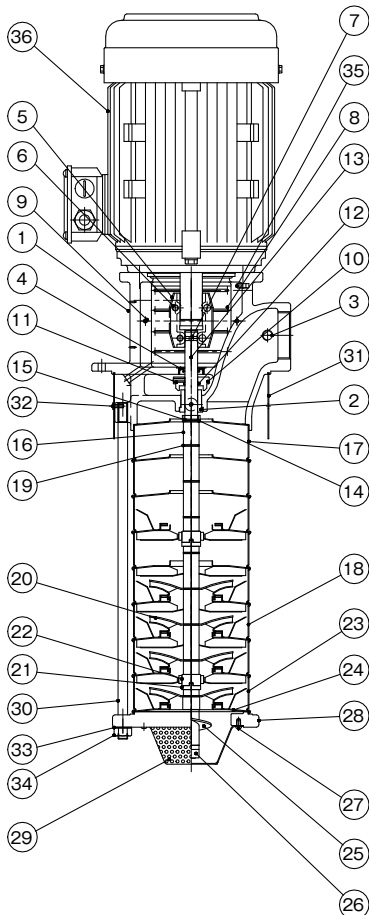

No.	Part name	Material
1	Discharge casing	SCS13
2	Bushing	SUS430
3	Plug	SUS304
4	Oil seal	NBR
5	Coupling	FC0205
6	Hexagon socket head bolt	SCM435
7	Shaft pin	SUS316
8	Coupling cover	SUS304
9	Cross-recessed pan head screw	SUS304
10	Oil thrower	SUS304
11	Set screw	SUS304
12	O-ring	FKM
13	Main shaft	SUS420J2
14	Shaft bushing	SUS304
15	Shaft ring	SUS316
16	Sleeve	SUS304
17	Intermediate casing (Final stage)	SUS304
18	Intermediate casing	SUS304
19	Shim	SUS304
20	Impeller	SUS304
21	Baffle	SUS304
22	Bearings	SiC
23	Bearing casing	SUS304+SiC
24	Intermediate casing (First stage)	SUS304
25	Screw	SUS304
26	Hard locknut	SUS304
27	Cross-recessed pan head screw	SUS304
28	Suction casing	SCS13
29	Strainer	SUS304
30	Through bolt	SUS304
31	Outer sleeve	SUS304
32	Cross-recessed flat head screw	SUS304
33	Plain washer	SUS304
34	Hexagon nut	SUS304
35	Hexagon bolt	SUS304
36	Motor	—

Note 1) The materials in the table above are equivalents.
Note 2) Structure and other details are subject to change without notice.

■ Features

- ① Non-seal (mechanical seal-less) structure is adopted.
- ② Three immersion depth options are available.
- ③ The lineup including the models complying with global standards by supporting efficiency and other regulations.
 Japan : Top Runner efficiency
 Europe : IE3 efficiency, CE marking (EU Directive)
 RoHS Directive (2011/65/EU), 10 substances restricted
 USA : NEMA Premium efficiency (IE3 efficiency), UL standards (safety)
 Canada : CSA standards (IE3 efficiency, safety)
 China : GB3 (GB18613-2020)
- ④ The expanded lineup of VKP-A (flow type) and VKP-H (pressure type) allows for a wider range of head and flow rate selection.
 The VKN-H achieves approximately 30% higher pressure compared to the VKN-A.



Please note that the paint color, etc. of the actual unit may partially differ from the photo.

■ Description of types

VKN 08 1 A T

① ② ③ ④ ⑤ ⑥

- ① Model
- ② Output 03:20W, 04:40W, 05:60W, 06:100W, 07:180W, 08:250W, 09:400W, 11:750W
- ③ Series No.
- ④ Phase, Features (A, J Note:3-phase, flow type, H:3-phase, pressure type)
- ⑤ Internal code
- ⑥ None : Standard efficiency / Standard voltage
 -e : Top Runner efficiency (equivalent to IE3) / Standard voltage
 -4Z : Standard efficiency / Different voltage
 -4Z-e : Top Runner efficiency (equivalent to IE3) / Different voltage
 -7W : NEMA premium efficiency motor with UL/CSA certification
 (For outputs below 750W, efficiency certification is not required; compliance with safety standards only.)

■ Global standards

Type	Standards/Regulations	Output		
		40W-250W	400W	750W
VKN	IE1 equivalent	●	●	
	CE Marking	●	●	
	EU energy efficiency	—	—	
	GB3	—	—	
VKN-e	Top Runner efficiency (IE3 equivalent)	X		●
	CE Marking			●
	EU energy efficiency			●
	GB3			●*1
VKN-7W	NEMA Premium efficiency	—	—	●
	UL Standards (safety)	●	●	●
	CSA Standards (efficiency)	—	—	●
	CSA Standards (safety)	●	●	●

*1 Dedicated product for attaching GB certification label. ● : Compliant — : Not applicable

■ Standard Specification

Liquid used	Property of liquid	Grinding liquid, cutting liquid, etc.*1
	Liquid temperature	-20 to 60°C (No frozen liquid)
	Allowable kinematic viscosity	VKN-A 50Hz:150mm ² /s 60Hz:75mm ² /s VKN-H 50/60Hz : 32mm ² /s
Installation location		Indoor Ambient temperature:-15-40°C, 90% RH or less (No condensation) Height above sea level : 1000m or less Place not exposed to direct sunlight Place in an area free of corrosive or explosive gas or vapor
Material	Casing	FC150
	Impeller	SUS304
	Main shaft	S35C
Shaft seal structure		Mechanical seal (SiC vs Ceramic)
Motor	Power source	3-phase 50/60/60Hz 200/200/220V
	Type	Output 250W or less: Totally enclosed self-cooled type Output 400W or more: Totally enclosed fan-cooled indoor type
	Protection method	Output 250W or less:IP54 Output 400W or less:IP44
	Thermal class	B class**2
	Rating	Continuous
	No. of poles	2P
	Standard	IEC60034-1 CE Marking**3
	Bearing	Deep groove ball bearing / Urea grease
Painting	Paint color	Munsell N1
	Painting specifications	Epoxy resin painting

*1 Take note that special liquid such as water, printing liquid or acid liquid cannot be used. Contact us for other special liquid (ceramic, etc.).
 **2 -7W type is A class.
 **3 Excluding -7W type.

■ Table of Consumable Parts

Type	Bearing		O-ring for casing
	Load side	Unload side	
VKN041AT (-4Z/7W)	6202ZZ	6200CXZZ	G95
VKN051AT (-4Z/7W)	6203ZZ	6201CXZZ	G100
VKN061AT (-4Z/7W)	6203ZZ	6201CXZZ	G100
VKN071AT (-4Z/7W)	6203ZZ	6201CXZZ	G125
VKN081AT (-4Z/7W)	6203ZZ	6201CXZZ	G125
VKN091AT (-4Z/7W)	6203ZZ	6201CXZZ	G140
VKN111AT-e (-4Z/7W)	6203ZZ	6203CXZZ	G140
VKN051HT (-4Z/7W)	6203ZZ	6201CXZZ	G100
VKN071HT (-4Z/7W)	6203ZZ	6201CXZZ	G125
VKN081HT (-4Z/7W)	6203ZZ	6201CXZZ	G125
VKN091HT (-4Z/7W)	6203ZZ	6201CXZZ	G140

Selection chart

Synchronous rotating speed 50Hz : 3000min⁻¹
60Hz : 3600min⁻¹

●VKN

(Values at kinematic viscosity 1mm²/s, specific gravity 1)

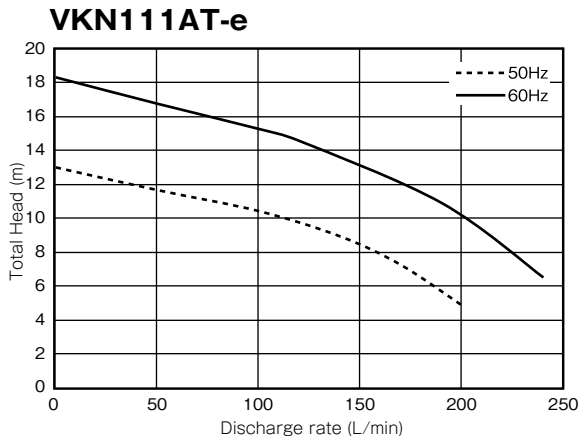
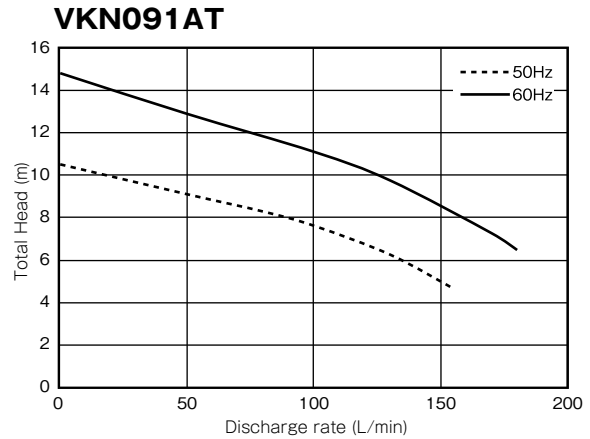
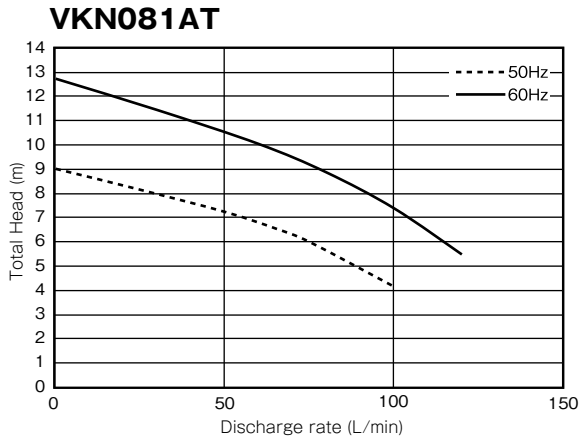
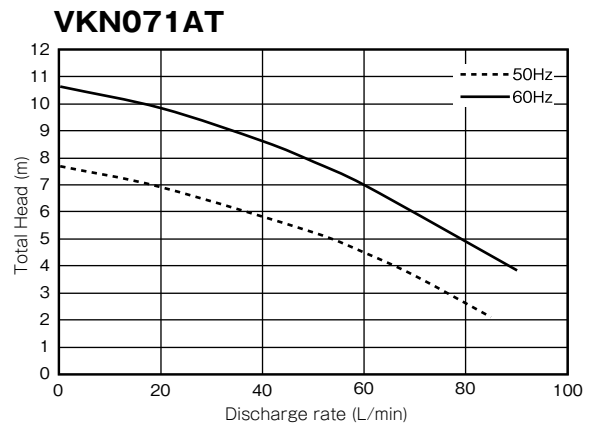
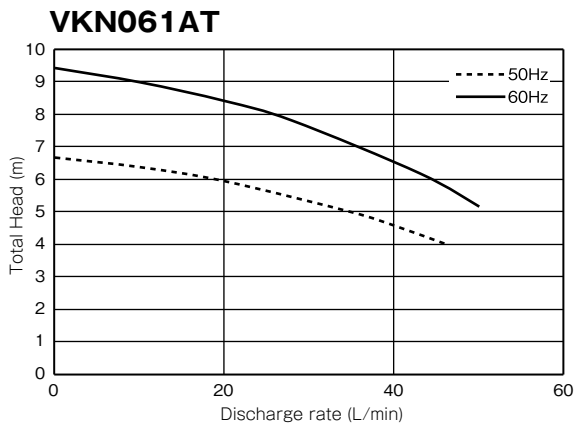
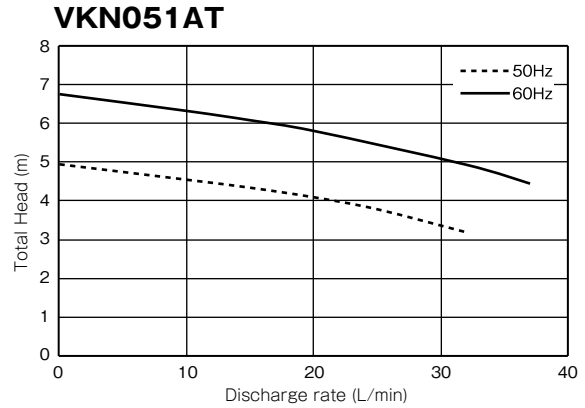
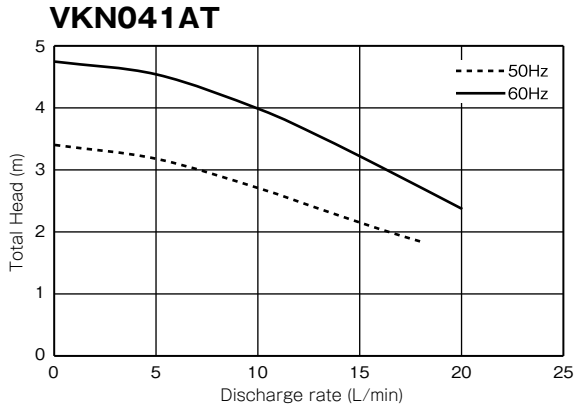

* Above selection chart is also available for -4Z/-7W.

Note) Take note that discharge rate varies considerably depending on the type and kinematic viscosity of liquid used.

Selection chart

(Values at kinematic viscosity 1mm²/s, specific gravity 1)

Synchronous rotating speed 50Hz : 3000min⁻¹
60Hz : 3600min⁻¹

●VKN-H

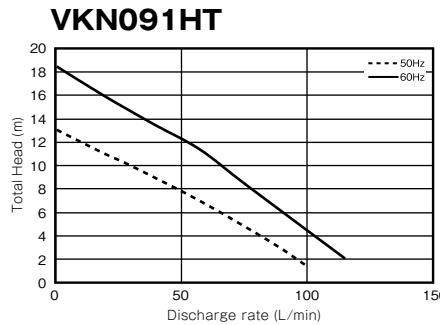
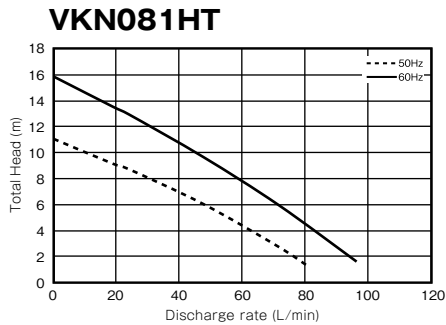
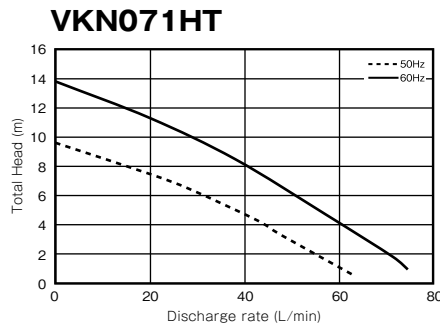
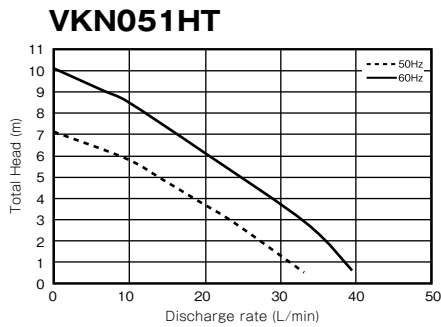

※ This chart also applies to -4Z/-7W.
Note) Take note that discharge rate varies considerably depending on the type and kinematic viscosity of liquid used.

Specification table

●VKN

Bore diameter (Rp)	Type	Output (W)	50Hz					60Hz					Max. length of suction pipe
			Rated voltage V	Rated current A	Starting current A	Discharge rate L/min	Total head m	Rated voltage V	Rated current A	Starting current A	Discharge rate L/min	Total head m	
1/4	VKN041AT	40	200	0.32	1.1	13	1.5	200/220	0.32/0.31	1.03/1.14	16	1.5	0.7
	VKN041AT-4Z		380/400/415	0.16/0.16/0.16	0.5/0.5/0.6			400/440/460	0.16/0.16/0.16	0.5/0.6/0.6			
	VKN041AT-7W							208/230/460	0.3/0.2	1.1/1.3			
3/8	VKN051AT	60	200	0.55	2.6	25	2	200/220	0.6/0.6	2.5/2.7	32	2	0.7
	VKN051AT-4Z		380/400/415	0.27/0.27/0.27	1.4/1.4/1.5			400/440/460	0.3/0.3/0.3	1.3/1.4/1.5			
	VKN051AT-7W				208/230/460	0.4/0.4/0.2	2.7/2.9/1.7						
	VKN061AT	100	200	0.70	2.9	35	2	200/220	0.75/0.75	2.8/3.1			
	VKN061AT-4Z		380/400/415	0.35/0.35/0.35	1.7/1.7/1.8			400/440/460	0.38/0.38/0.38	1.6/1.7/1.8			
VKN061AT-7W				208/230/460	0.5/0.5/0.3			3.1/3.4/1.9					
1/2	VKN071AT	180	200	1.2	6.1	50	3	200/220	1.4/1.4	5.6/6.2	60	3	0.7
	VKN071AT-4Z		380/400/415	0.6/0.6/0.6	2.8/3.0/3.0			400/440/460	0.7/0.7/0.7	2.8/3.1/3.2			
	VKN071AT-7W							208/230/460	0.8/0.8/0.4	6.1/6.8/3.6			
3/4	VKN081AT	250	200	1.4	7.5	75	4	200/220	1.6/1.6	6.9/7.6	100	4	0.6
	VKN081AT-4Z		380/400/415	0.7/0.7/0.7	3.5/3.7/3.8			400/440/460	0.8/0.8/0.8	3.3/3.7/3.8			
	VKN081AT-7W							208/230/460	1.1/1.0/0.5	7.5/8.3/4.1			
1	VKN091AT	400	200	2.1	9.6	130	5	200/220	2.4/2.4	9.1/10.0	170	5	0.7
	VKN091AT-4Z		380/400/415	1.05/1.05/1.05	4.6/4.8/5.0			400/440/460	1.2/1.2/1.2	4.6/5.0/5.2			
	VKN091AT-7W				208/230/460	1.6/1.5/0.8	9.9/11/5.5						
	VKN111AT-e	750	200	3.3	27.2	140	7	200/220	4.5/4.2	26.9/28.9			
	VKN111AT-4Z-e		380/400/415	1.7/1.7/1.7	12.9/14.4/15.1			400/440/460	2.3/2.3/2.3	13.5/13.8/16.0			
VKN111AT-7W				208/230/460	3.1/2.9/1.5	29/31/17							

Notes 1) The discharge rate and total head are values obtained from tests conducted at a kinematic viscosity of 1mm²/s (same as normal temperature fresh water). Take note that the pumps cannot be used with water.
Notes 2) The rated current in the table above (rated current shown on the pump nameplate) is the recommended set current of the protective device.

●VKN-H

Bore diameter (Rp)	Type	Output (W)	50Hz					60Hz					Max. length of suction pipe
			Rated voltage V	Rated current A	Starting current A	Discharge rate L/min	Total head m	Rated voltage V	Rated current A	Starting current A	Discharge rate L/min	Total head m	
3/8	VKN051HT	60	200	0.55	2.6	10	5.7	200/220	0.6/0.6	2.5/2.7	10	8.5	0.7
	VKN051HT-4Z		380/400/415	0.27/0.27/0.27	1.4/1.4/1.5			400/440/460	0.3/0.3/0.3	1.3/1.4/1.5			
	VKN051HT-7W							208/230/460	0.4/0.4/0.2	2.7/2.9/1.7			
1/2	VKN071HT	180	200	1.2	6.1	20	7.5	200/220	1.4/1.4	5.6/6.2	20	11.3	0.7
	VKN071HT-4Z		380/400/415	0.6/0.6/0.6	2.8/3.0/3.0			400/440/460	0.7/0.7/0.7	2.8/3.1/3.2			
	VKN071HT-7W							208/230/460	0.8/0.8/0.4	6.1/6.8/3.6			
3/4	VKN081HT	250	200	1.4	7.5	20	9	200/220	1.6/1.6	6.9/7.6	20	13.2	0.6
	VKN081HT-4Z		380/400/415	0.7/0.7/0.7	3.5/3.7/3.8			400/440/460	0.8/0.8/0.8	3.3/3.7/3.8			
	VKN081HT-7W							208/230/460	1.1/1.0/0.5	7.5/8.3/4.1			
1	VKN091HT	400	200	2.1	9.6	20	10.5	200/220	2.4/2.4	9.1/10.0	20	16	0.6
	VKN091HT-4Z		380/400/415	1.05/1.05/1.05	4.6/4.8/5.0			400/440/460	1.2/1.2/1.2	4.6/5.0/5.2			
	VKN091HT-7W							208/230/460	1.6/1.5/0.8	9.9/11/5.5			

Notes 1) The discharge rate and total head are values obtained from tests conducted at a kinematic viscosity of 1mm²/s (same as normal temperature fresh water). Take note that the pumps cannot be used with water.
Notes 2) The rated current in the table above (rated current shown on the pump nameplate) is the recommended set current of the protective device.

Assembly drawing

Fig.1

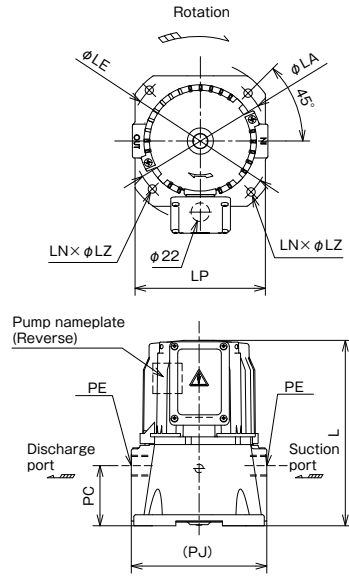
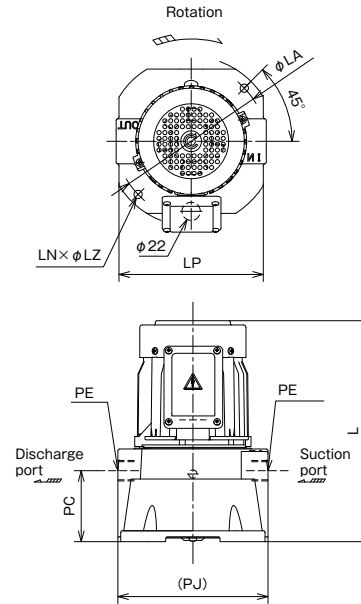

Fig.2



Dimensions

●VKN

(Unit : mm)

Type	Output (kW)	Fig.	LA	LE	LP	LN	LZ	PE	PC	PJ	L	Power supply terminal screw size	Ground terminal screw size	Approx. mass (kg)
VKN041AT(-4Z/7W)	0.04	1	130	—	124	4	7	Rp 1/4	44	124	187	M4	M4	5.8
VKN051AT(-4Z/7W)	0.06	1	132	130	132	2/2	7/7	Rp 3/8	56	132	171	M4	M4	8.0
VKN061AT(-4Z/7W)	0.10	1	132	150	132	2/2	7/7	Rp 3/8	56	132	171	M4	M4	8.0
VKN071AT(-4Z/7W)	0.18	1	160	164	154	2/2	10/10	Rp 1/2	63	150	219	M4	M4	10.0
VKN081AT(-4Z/7W)	0.25	1	160	170	154	2/2	10/10	Rp 3/4	71	160	219	M4	M4	11.2
VKN091AT(-4Z/7W)	0.40	2	180	—	173	2	10	Rp 1	85	180	264	M4	M4	14.0
VKN111AT-e(-4Z/7W)	0.75	2	180	—	173	2	10	Rp 1	85	180	323	M4	M4	21.0

●VKN-H

(Unit : mm)

Type	Output (kW)	Fig.	LA	LE	LP	LN	LZ	PE	PC	PJ	L	Power supply terminal screw size	Ground terminal screw size	Approx. mass (kg)
VKN051HT(-4Z/7W)	0.06	1	132	130	132	2/2	7/7	Rp 3/8	56	132	171	M4	M4	8.0
VKN071HT(-4Z/7W)	0.18	1	160	164	154	2/2	10/10	Rp 1/2	63	150	219	M4	M4	10.0
VKN081HT(-4Z/7W)	0.25	1	160	170	154	2/2	10/10	Rp 3/4	71	160	219	M4	M4	11.2
VKN091HT(-4Z/7W)	0.40	2	180	—	173	2	10	Rp 1	85	180	264	M4	M4	14.0

■ Detailed drawing of the terminal box

●VKN041AT~111AT-e (-4Z)
VKN051HT~091HT (-4Z)

■ Assembly drawing

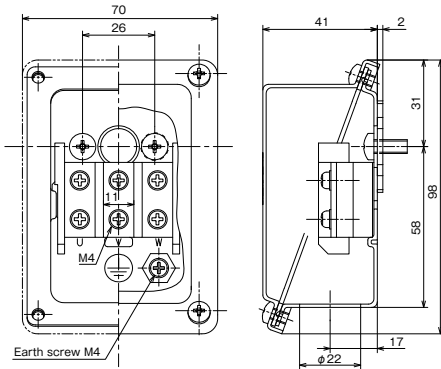

■ Connection diagram

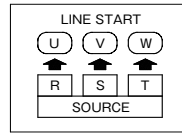

※ CE marked product
※ IP54-equivalent protective structure (However, for wiring ports, please use wiring pipes (conduits) with IP54 or higher.)

●VKN041AT-7W

■ Assembly drawing

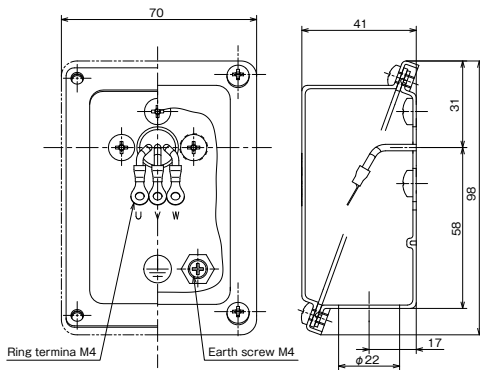

■ Connection diagram

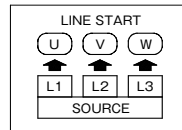

●VKN051AT-7W~111AT-7W
VKN051HT-7W~091HT-7W

■ Assembly drawing

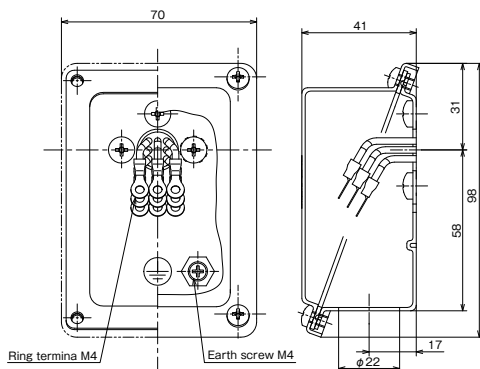

■ Connection diagram

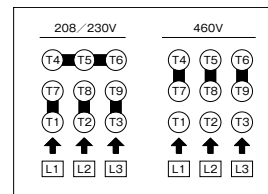

Sectional drawing

●VKN-A (-4Z/-7W), VKN-H (-4Z/-7W)

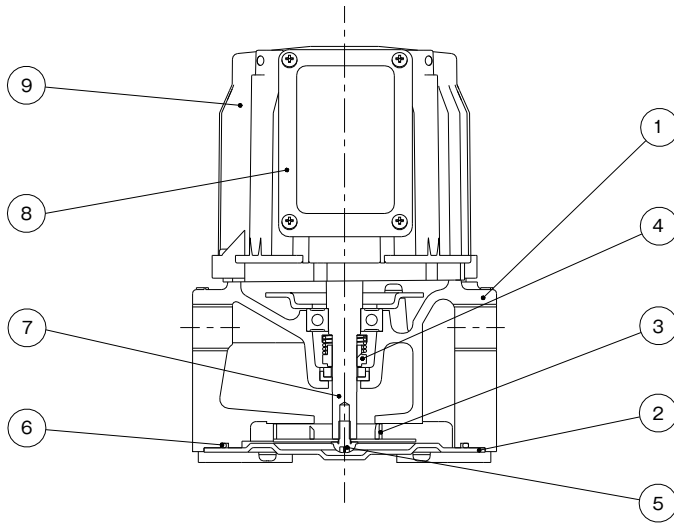

No.	Part name	Material	No.	Part name	Material
1	Casing	FC150	6	O ring	NBR
2	Bottom plate	SEHC	7	Main shaft	S35C
3	Impeller	SUS304	8	Terminal box	SPCE
4	Mechanical seal	SIC ~ CERAMIC	9	Motor	—
5	SEMS screw	SWCH			

Note 1) Structure and other details are subject to change without notice.

Selection chart

●For low viscosity liquid (Values at kinematic viscosity 1mm²/s, specific gravity 1)

50Hz

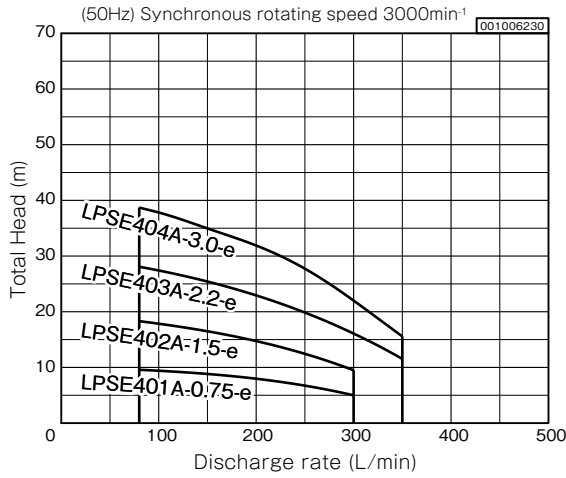

60Hz

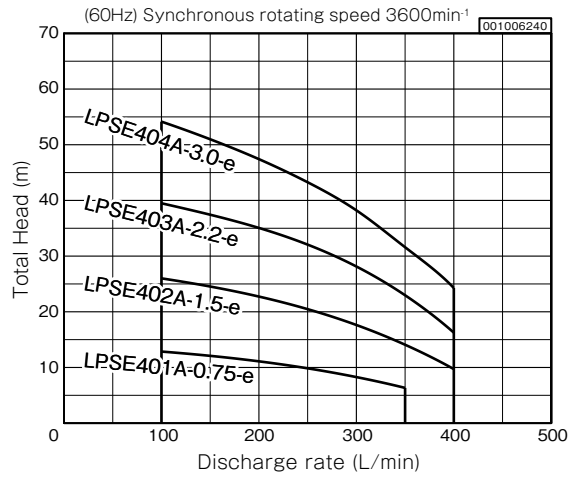

●For high-viscosity liquid (Value at kinematic viscosity 150mm²/s, kinematic viscosity, specific gravity 1)

50Hz

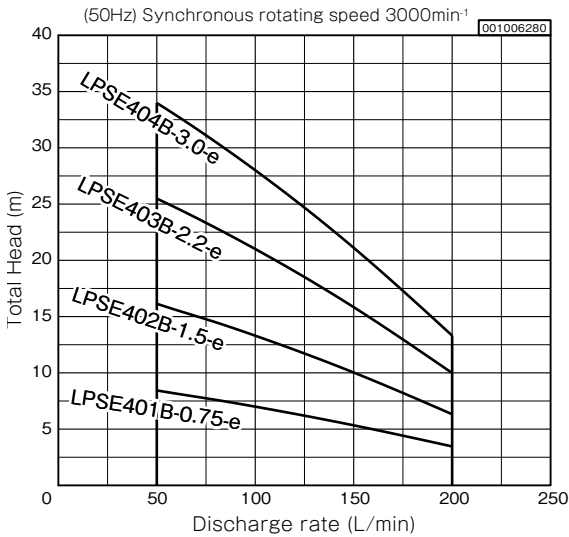

60Hz

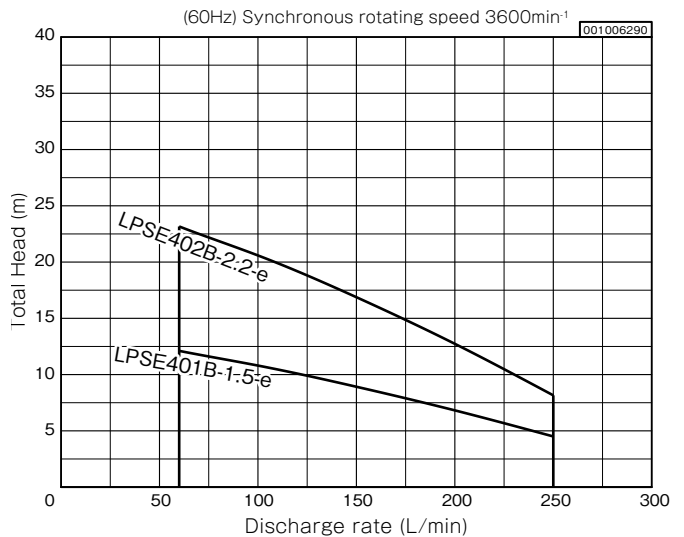

■ Specification table

●LPSE-e

Bore diameter (mm)	Frequency (Hz)	Used liquid	Output (kW)	Type	Rated voltage (V)	Rated current (A)	Starting current (A)	Allowable ampacity (A)	Standard specification	
									Applied flow rate range L/min	Total head (m)
40	50	For low viscosity liquid	0.75	LPSE401A-0.75-e	200	3.6	28	4.0	80-300	9.5-4.9
			1.5	LPSE402A-1.5-e	200	6.1	64	7.8		18.3-9.4
			2.2	LPSE403A-2.2-e	200	8.6	86	10.0	80-350	28.0-11.5
			3	LPSE404A-3.0-e	200	12.6	164	16.0		38.7-15.5
		For high-viscosity liquid	0.75	LPSE401B-0.75-e	200	3.5	28	4.0	50-200	8.4-3.5
			1.5	LPSE402B-1.5-e	200	6.2	64	7.8		16.1-6.3
			2.2	LPSE403B-2.2-e	200	9.0	86	10.0		25.5-10.0
			3	LPSE404B-3.0-e	200	12.5	164	16.0		34.0-13.3
	60	For low viscosity liquid	0.75	LPSE401A-0.75-e	200/220	4.0	27/29	4.0	100-350	12.8-6.3
			1.5	LPSE402A-1.5-e	200/220	7.5	61/68	7.8	100-400	26.0-9.7
			2.2	LPSE403A-2.2-e	200/220	10.0	79/87	10.0		39.4-16.2
			3	LPSE404A-3.0-e	200/220	14.0	129/144	16.0		54.1-24.2
		For high-viscosity liquid	1.5	LPSE401B-1.5-e	200/220	6.0	61/68	7.8	50-250	12.5-4.5
			2.2	LPSE402B-2.2-e	200/220	8.4	79/87	10.0		23.9-8.2

Note 1) The pump's rated current (current value listed on the pump nameplate) is the recommended current setting for protection device.

Note 2) The allowable ampacities (current value listed on the pump nameplate) in the table above are the maximum current that a motor can safely carry without overheating. When changing the thermal relay setting value based on the compatibility of the protective device employed (quick acting type, for example) or the operational environment (ambient temperature, power supply devices etc.), keep the current value below the allowable ampacity.

●LPSE-e (50Hz 380V)

Bore diameter (mm)	Frequency (Hz)	Used liquid	Output (kW)	Type	Rated voltage (V)	Rated current (A)	Starting current (A)	Allowable ampacity (A)	Standard specification	
									Applied flow rate range L/min	Total head (m)
40	50	For low viscosity liquid	0.75	LPSE401A-0.75-e	380	2.0	13	2.2	80-300	9.5-4.9
			1.5	LPSE402A-1.5-e	380	3.1	33	4.5		18.3-9.4
			2.2	LPSE403A-2.2-e	380	5.0	43	5.0	80-350	28.0-11.5
			3	LPSE404A-3.0-e	380	6.0	73	8.0		38.7-15.5
		For high-viscosity liquid	0.75	LPSE401B-0.75-e	380	2.0	13	2.2	50-200	8.4-3.5
			1.5	LPSE402B-1.5-e	380	3.1	33	4.5		16.1-6.3
			2.2	LPSE403B-2.2-e	380	5.0	43	5.0		25.5-10.1
			3	LPSE404B-3.0-e	380	6.2	73	8.0		34.0-13.5

Note 1) The pump's rated current (current value listed on the pump nameplate) is the recommended current setting for protection device.

Note 2) The allowable ampacities (current value listed on the pump nameplate) in the table above are the maximum current that a motor can safely carry without overheating. When changing the thermal relay setting value based on the compatibility of the protective device employed (quick acting type, for example) or the operational environment (ambient temperature, power supply devices etc.), keep the current value below the allowable ampacity.

Assembly drawing

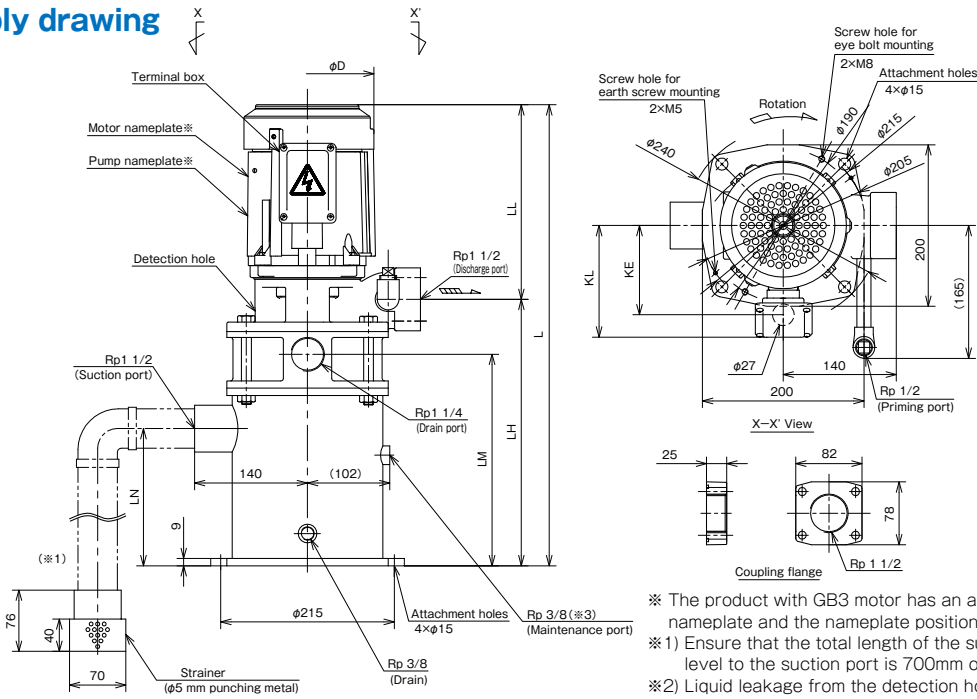

- ※ The product with GB3 motor has an additional certification nameplate and the nameplate position is different.
- ※1) Ensure that the total length of the suction pipe from the liquid level to the suction port is 700mm or less.
- ※2) Liquid leakage from the detection hole is abnormal. Please check around the drain.
- ※3) If the siphon preventive hole inside the pump is clogged, it may cause disabling suction. Inspect the pump from the cleaning port.

Dimensions

(Unit : mm)

Bore diameter (mm)	Frequency (Hz)	Used liquid	Type	φD	KL	KE	L	LH	LL	LM	LN	Approx. mass (kg)	
40	50	For low viscosity liquid	LPSE401A-0.75-e	170	139	111	571	330	241	262	170	39	
			LPSE402A-1.5-e	195	145	117	604	330	274	262	170	46	
			LPSE403A-2.2-e	195	145	117	614	330	284	262	170	56	
			LPSE404A-3.0-e	195	145	117	689	375	314	307	215	61	
	For high-viscosity liquid	LPSE401B-0.75-e	170	139	111	571	330	241	262	170	39		
		LPSE402B-1.5-e	195	145	117	604	330	274	262	170	46		
		LPSE403B-2.2-e	195	145	117	614	330	284	262	170	56		
		LPSE404B-3.0-e	195	145	117	689	375	314	307	215	61		
		60	For low viscosity liquid	LPSE401A-0.75-e	170	139	111	571	330	241	262	170	39
				LPSE402A-1.5-e	195	145	117	604	330	274	262	170	46
LPSE403A-2.2-e	195			145	117	614	330	284	262	170	56		
LPSE404A-3.0-e	195			145	117	689	375	314	307	215	61		
For high-viscosity liquid	LPSE401B-1.5-e		195	145	117	604	330	274	262	170	45		
	LPSE402B-2.2-e		195	145	117	614	330	284	262	170	55		

※ Above specification is also available for different voltage specification.

Detailed drawing of the terminal box

Assembly drawing

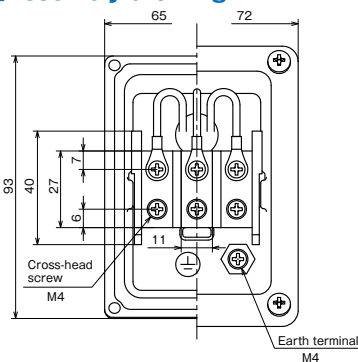

Connection diagram

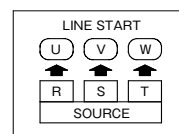

Sectional drawing

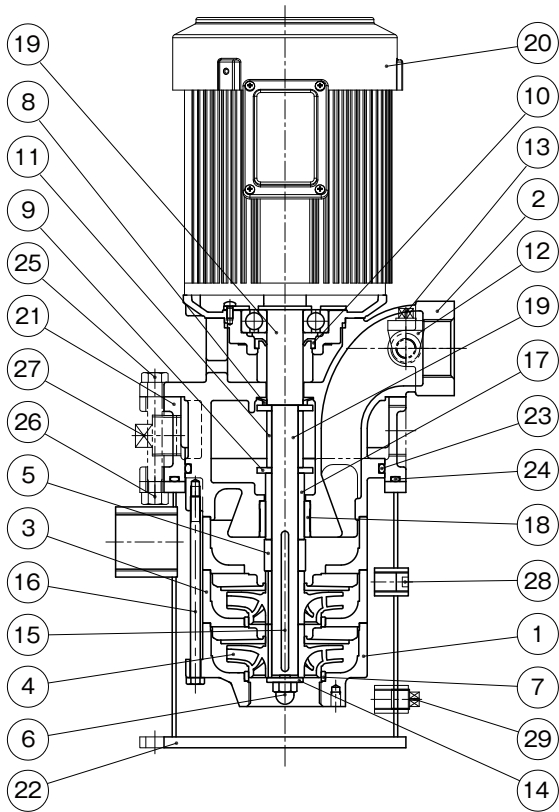

No.	Part name	Qty	Material
1	Suction casing	1	FC200
2	Discharge casing	1	FC200
3	Intermediate casing	2	FC200
4	Impeller	2	FCD450
5	Shaft spacer	1	STKM
6	Impeller nut	1	SUS304
7	Wearing ring	2	SUS304
8	Deflector	1	NBR
9	Deflector	2	SPHC
10	Oil seal	1	NBR
11	Collar	1	STKM
12	Elbow	1	FCMB
13	Plug	1	SWCH
14	Washer	1	SUS304
15	Key	1	S45C
16	Through bolt	4	SS400
17	Shaft sleeve	1	SUS440C
18	Discharge bushing	1	SKD11
19	Motor shaft	1	S45C
20	Motor	1	-
21	Suction spacer	1	FC200
22	Suction pipe	1	SS400
23	O-ring	1	NBR
24	O-ring	1	NBR
25	Through bolt	4	SS400
26	Nut	4	SWCH
27	Plug	1	FCMB
28	Hexagonal socket sunk plug	1	SS400
29	Plug	1	SWCH

Note 1) The materials in the table above are equivalents.
 Note 2) Structure and other details are subject to change without notice.
 Applicable models : LPSE402A(B)-1.5-e · LPSE402B-2.2-e

■ Features

- ① Energy-saving pump with a Top Runner (equivalent to IE3) motor (LPS-e).
- ② The structure and materials are not easily affected by dirty coolants.
- ③ The impeller made of FCD material and non-seal (mechanical seal-less) structure is adopted for excellent durability.
- ④ The self-priming function and floor mount offer a wider choice of installation location, not limited to the top of the tank.
- ⑤ The lineup includes the models that meet the efficiency of the various regulations:
LPS-e type : Equipped with a Top Runner (equivalent to IE3) motor.
(NEMA Premium motor)



Please note that the paint color, etc. of the actual unit may partially differ from the photo.

■ Description of types

LPS 65 3 / 2 A - 5 7.5 T -e

① ② ③ ④ ⑤ ⑥ ⑦ ⑧ ⑨

- | | |
|-----------------------|--|
| ① Model | ⑥ Frequency 5:50Hz 6:60Hz |
| ② Bore diameter | ⑦ Output |
| ③ Number of casings | ⑧ ID code |
| ④ Number of impellers | ⑨ Motor efficiency Top Runner efficiency (equivalent to IE3) |
| ⑤ Liquid viscosity | |
- A : for low viscosity liquid

■ Standard Specification

Bore diameter		65mm
Used liquid	Property of liquid	Water-soluble coolant liquid
	Temperature	0 to 60° C (No frozen liquid)
	Allowable kinematic viscosity	1mm ² /s
Installation location		Indoor Ambient temperature: 0 to 40 ° C, RH 85% or below (no condensation). Height above sea level : 1000m or less. Place not exposed to direct sunlight. Place in an area free of corrosive or explosive gas or vapor.
Max. intake piping length		0.7m*2
Material	Casing (Suction-Discharge-Intermediate)	FC200
	Impeller	FCD450
	Shaft	S45C
Shaft seal structure		Non-seal (mechanical seal-less)
Motor	Power source	3-phase 50/60/60Hz 200/200/230V
	Type	Totally enclosed fan-cooled outdoor type*3
	Protection method	IP55
	Thermal class	F
	Rating	Continuous
	Number of poles	2P
Paint color		Munsell N1.5

*1 Avoid using the pump with water. Contact us when using the unit for coolant containing foreign substances with high hardness or a large amount of foreign substances including chips.

*2 Intake piping should be as short as possible and the number of bends and fittings as few as possible.

*3 The pump cannot be installed outdoors.

■ Special specification

Shaft seal structure is modified (to improve abrasion resistance).

■ Table of Consumable Parts

Output (kW)	Bearing		Oil seal	
	Load side	Unload side	Load side	Unload side
5.5	6309ZZC3	6306ZZC3	VC45628	VC30528
7.5	6309ZZC3	6306ZZC3	VC45628	VC30528

Bore diameter (mm)	O-ring (For interior surface of suction spacer)	O-ring (For bottom surface of suction spacer)	O-ring (For coolant sealing plate)
65	G270	G280	S56

Selection chart

●LPS65

●For low viscosity liquid (Values at kinematic viscosity 1mm²/s, specific gravity 1)

50Hz

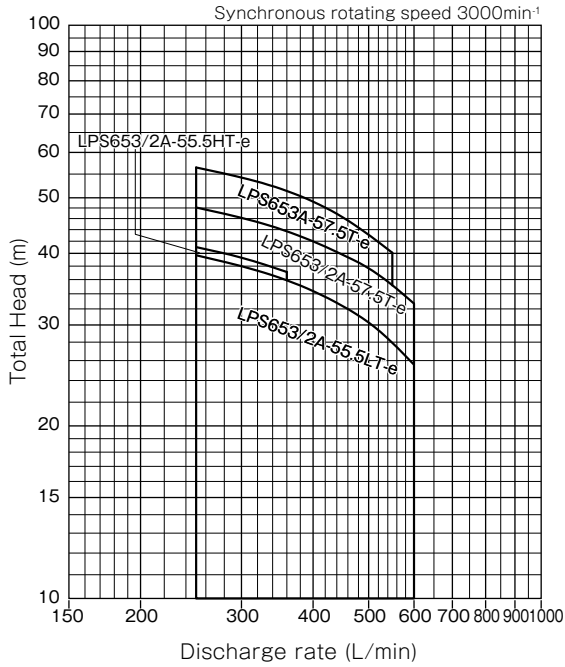

60Hz

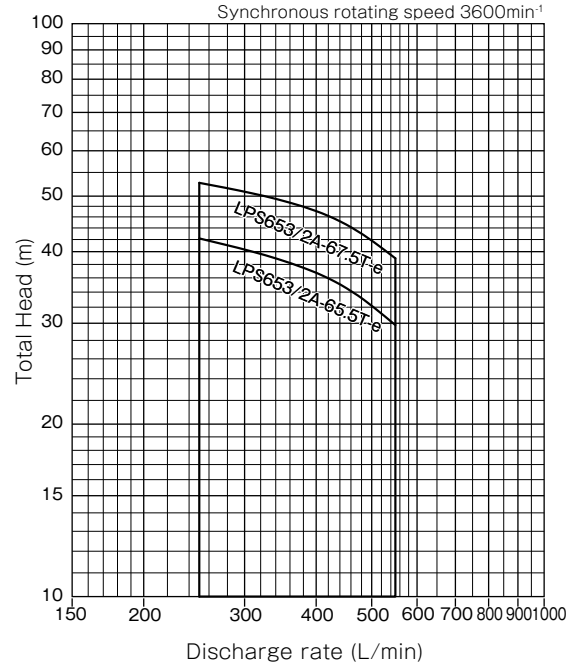

Specification table

●LPS65

Bore diameter (mm)	Frequency (Hz)	Type	Output (kW)	Rated voltage (V)	Rated current (A)	Starting current (A)	Discharge rate (L/min)	Total head (m)
65	50	LPS653/2A-55.5LT-e	5.5	200	20.3	204	250-600	39.7-25.6
		LPS653/2A-55.5HT-e	5.5		20.3	204	250-360	41.0-37.1
		LPS653/2A-57.5T-e	7.5		27.2	288	250-600	48.1-32.7
		LPS653A-57.5T-e	7.5		27.2	288	250-550	56.5-40.1
	60	LPS653/2A-65.5T-e	5.5	200/230	19.8/17.8	178/206	250-550	42.2-29.8
		LPS653/2A-67.5T-e	7.5		26.5/23.7	254/295	250-550	52.8-39.0

Assembly drawing

●LPS65

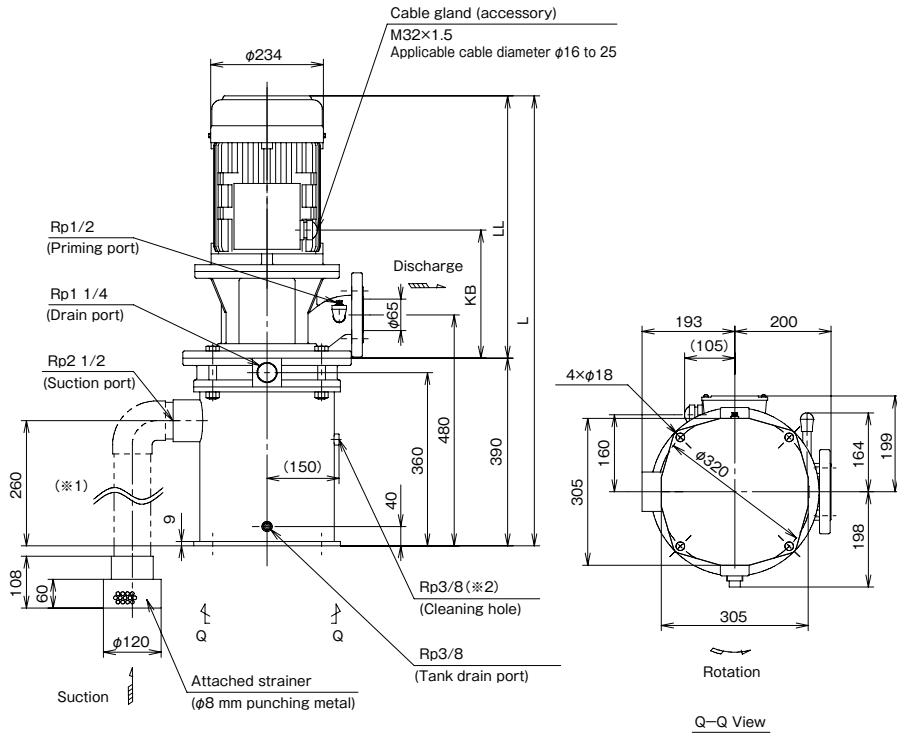

※1) The length of suction pipe from the liquid surface to the suction port should be shorter than 700 mm.
 ※2) If the siphon prevention hole is clogged, suction might be disabled. Inspect the interior via cleaning hole.
 A companion flange JIS 10K standard type is attached.

Dimensions

●LPS65

(Unit : mm)

Bore diameter (mm)	Frequency (Hz)	Type	L	LL	KB	Approx. mass(kg)	
65	50	LPS653/2A-55.5LT-e	935	545	266	135	
		LPS653/2A-55.5HT-e				135	
	60	50	LPS653/2A-57.5T-e	975	585	267	141
			LPS653A-57.5T-e				143
65	60	LPS653/2A-65.5T-e	935	545	266	135	
		LPS653/2A-67.5T-e				940	585

Detailed drawing of the terminal box

●LPS65-e

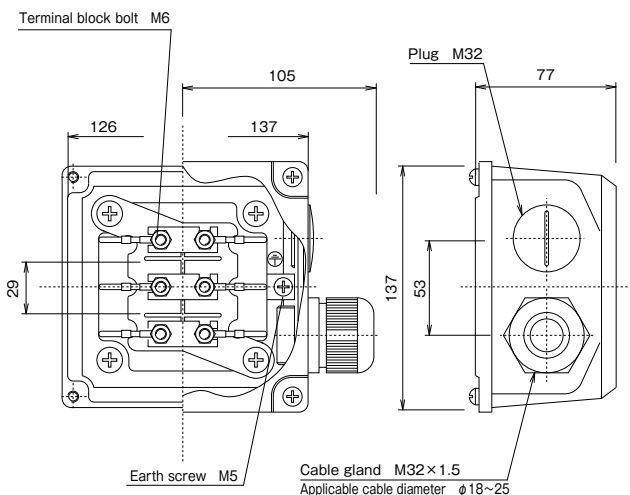

●LPS65-e

Connection diagram

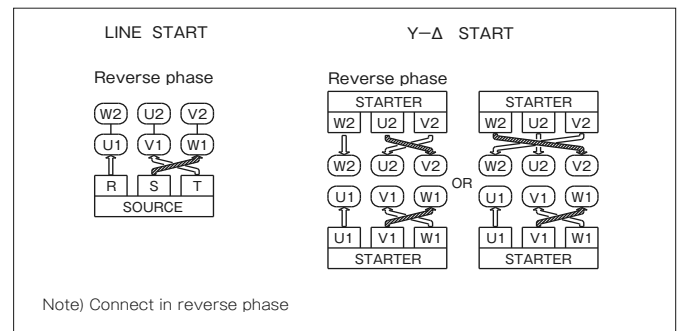

Sectional drawing

●LPS65

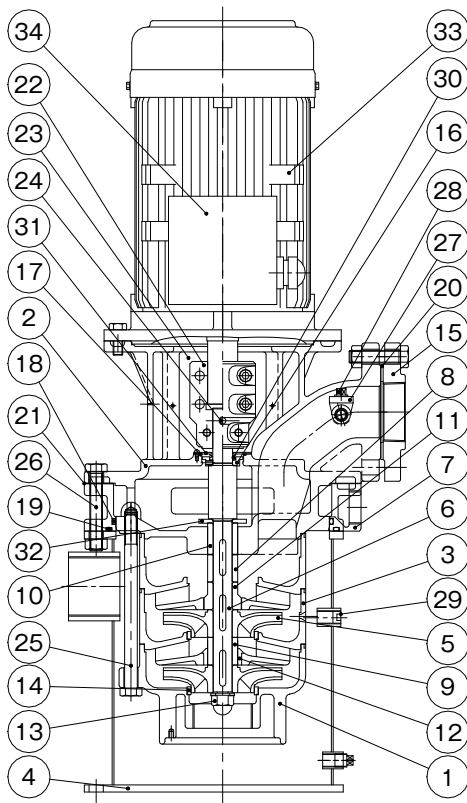

No.	Part name	Qty	Material
1	Suction casing	1	FC200
2	Discharge casing	1	FC200
3	Intermediate casing	2	FC200
4	Suction pipe	1	SS400
5	Impeller	2	FCD450
6	Main shaft	1	S45C
7	Suction spacer	1	FC200
8	Shaft sleeve A	1	SUS304
9	Shaft sleeve B	1	SiC
10	Shaft sleeve C	1	SUS304
11	Shaft sleeve D	1	SUS304
12	Intermediate bushing	1	SiC
13	Impeller nut	1	SUS304
14	Wearing ring	2	SUS304
15	Companion flange	1	FC200
16	Deflector	1	C3604B
17	O-ring	1	NBR
18	O-ring	1	NBR
19	O-ring	1	NBR
20	Sheet packing	1	NBR
21	Sheet packing	1	JOINT SHEET
22	Coupling	1	FC200
23	Coupling cover	2	SUS304
24	Hexagon socket set screw	1	SCM435
25	Through bolt	4	SS400
26	Through bolt	4	SS400
27	Elbow	1	FCMB
28	Plug	1	SS400
29	Hexagonal socket sunk plug	1	SS400
30	V-ring	1	FKM
31	Coolant sealing plate	1	SUS304
32	Deflector	1	SUS304
33	Motor	1	
34	Terminal box	1	ADC12

Note 1) The materials in the table above are equivalents.
 Note 2) Structure and other details are subject to change without notice.
 Applicable models: 50Hz LPS653/2A-55.5LT-e, LPS653/2A-55.5HT-e,
 LPS653/2A-57.5T-e
 60Hz LPS653/2A-65.5T-e, LPS653/2A-67.5T-e

■ Features

- ① Bubbles and chips floating on the liquid surface can be suctioned continuously.
- ② Complete exhaust structure to prevent air lock (patented).
- ③ V-shaped inlet allowing suction even when fluid level fluctuates (patented).
- ④ The sliding mechanism that allows for manual adjustment of inlet to achieve the best suction conditions according to the liquid level during operation (patented).
- ⑤ Impeller allowing simultaneous suction from both above and below is adopted (patented).

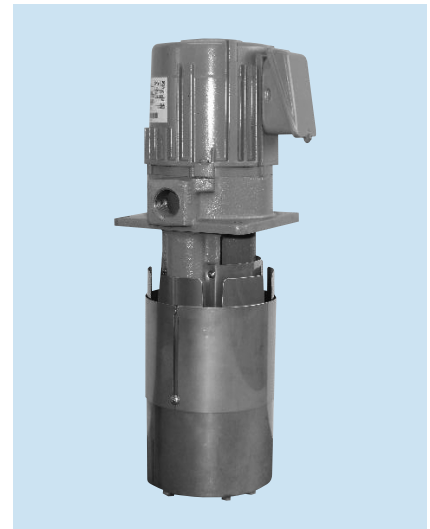
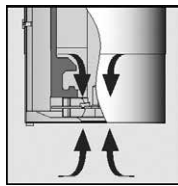
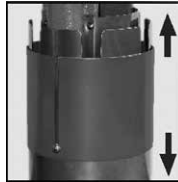
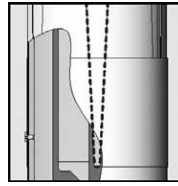

Please note that the paint color, etc. of the actual unit may partially differ from the photo.

The SKM Series resolves device failures caused by chips floating in the tank and the problems of fluid replacement and quality deterioration due to decayed sludge-like precipitate containing chips!

Effects generated from cleaning the coolant liquids:

- Improved processing accuracy
- Reduced manufacturing defects → Increased productivity → Cost reduction
- Reduced frequency of fluid replacement → Reduced frequency of disposal of oil waste → Environmental protection and cost reduction
→ Reduced amount of new oil to replace → Cost reduction
- Prevention of fluid decay → Improved work environment

■ Description of types

SKM-C 50 - L

① ② ③

- ① Model
- ② Discharge rate (L/min)
- ③ Head category L: low head
 H: high head

■ Selection chart

(Values at kinematic viscosity 1 mm²/s, specific gravity 1)

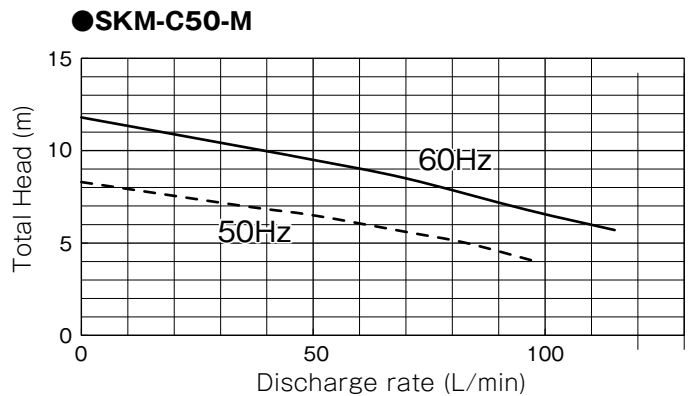
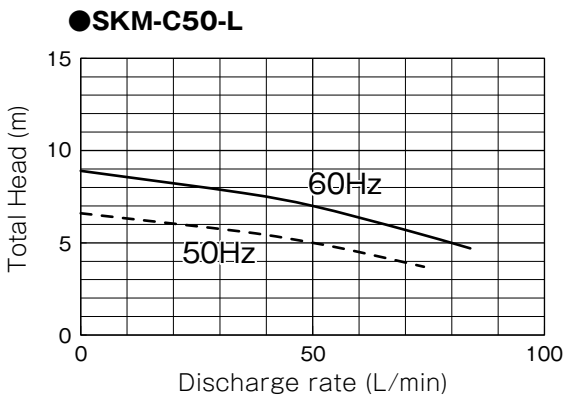

Note 1) The performance of the pump represents the performance when used with the recommended liquid level.
 Note 2) The performance of the pump may change depending on the liquid level during operation.
 Note 3) If the liquid level during operation is high or discharge is low, suction of the surface water will decrease.

Note 4) The pump should be installed in a place where the surface water is stable.
 Note 5) The pump should be used at a level higher than the lowest liquid level.
 Note 6) Suction is only carried out from the lower inlet if the liquid level is lower than the suction slit.

■ Specification table

Type		SKM-C50-L		SKM-C50-M		
Pump	Bore diameter	20mm				
	Discharge rate	50L/min	50L/min	50L/min	50L/min	
	Total head	5m	7m	6.5m	9.5m	
	Allowable kinematic viscosity	1mm ² /s				
	Liquid filtration accuracy	Medium filtration accuracy (Max. chip size allowed within the pump: 4 mm)				
	Materials	Bracket FC Impeller SUS304 S35C				
Motor	Phases	3-phase				
	Number of poles	2P				
	Output	0.18kW		0.25kW		
	Voltage	200V	200/220V	200V	200/220V	
	Rated current	1.0A	1.1/1.0A	1.6A	1.7/1.6A	
	Frequency	50Hz	60Hz	50Hz	60Hz	
	Synchronous rotating speed	3000min ⁻¹	3600min ⁻¹	3000min ⁻¹	3600min ⁻¹	
	Thermal class	B				
	Ambient temperature	0 to 40°C				
	Rating	Continuous				
	Protection method	Totally enclosed self-cooling indoor type		Totally enclosed fan-cooled indoor type		
	Bearing	Load side	6203ZZ			
		Unload side	6201ZZAC			
Paint color	Munsell N5.5					

■ Assembly drawing

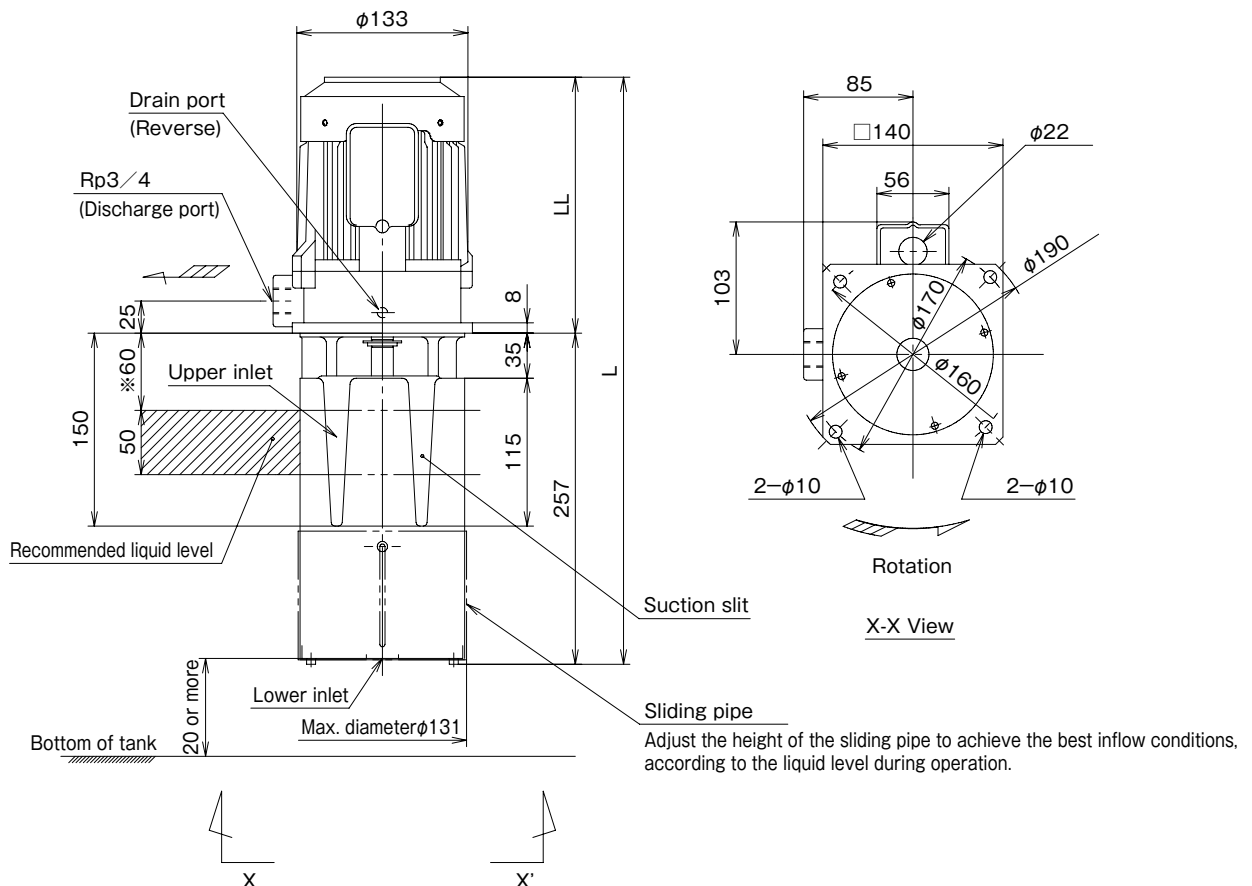

■ Dimensions

(Unit : mm)

Type	L	LL	Approx. mass(kg)
SKM-C50-L	428	171	14.5
SKM-C50-M	456	199	15.0

※ When the liquid level during operation reaches 120mm or more below the base, the pump switches to the air suction operation.
When the nominal discharge rate is exceeded, the pump also switches to the air suction operation.



TERAL INC.

Head Office 230, Moriwake, Miyuki-cyo, Fukuyama-city, Hiroshima, 720-0003, Japan
Tel.+81-84-955-1111 Fax.+81-84-955-5777
www.teral.net

Teral Asia Limited

Room 1001,10/F, Olympia Plaza, 255 King's Road, North Point, Hong Kong
Tel.+852-2571-0935 Fax.+852-2571-0619

TERAL THAI CO.,LTD.

150 Moo 16 Udomsoraryuth Rd., T.Bangkrasan, A.Bangpa-In, Ayutthaya 13160 Thailand
Tel.+66-3535-2148-9 Fax.+66-3535-2150

TERAL TRADING & SERVICE CO.,LTD.

150 Moo 16 Udomsoraryuth Rd., T.Bangkrasan, A.Bangpa-In, Ayutthaya 13160 Thailand
Tel.+66-3535-2145-7 Fax.+66-3535-8549

PT.Teral Indonesia Pumps and Fans

Sinpasa Commercial Blok SB No 001
Jl. Boulevar Selatan Summarecon Bekasi
RT.003/RW.005, Kel. Marga Mulya, Kec. Bekasi Utara, Kota Bekasi, Jawa Barat 17142
TEL:+62-21-8949-4116

Teral Vietnam Limited Liability Company

9th Floor, LADECO Building, No.266 Doi Can Street, Ngoc Ha Ward, Hanoi City, Vietnam
Tel.+84-24-393-52-790 Fax.+84-24-393-52-289

Teral General Machine (Shanghai) Co.,Ltd.

No.285, Yuan Qu Road(N), Bei Qiao, Min Hang District, Shanghai 201109, China
Tel.+86-21-6490-9128 Fax.+86-21-6490-9126

Teral Middle East F.Z.C.

1806-002, 18th floor, BB1, Mazaya Business Avenue, JLT, Dubai, UAE. PO Box 414781
Tel.+971-4369 9039

Teral Pumps & Fans North America Ltd.

Suite # 197, 800-15355 24 Ave Surrey, B.C., CANADA V4A 2H9
Tel.+1-604-839-1008