

Pressure Fans

TERAL

50Hz / 60Hz

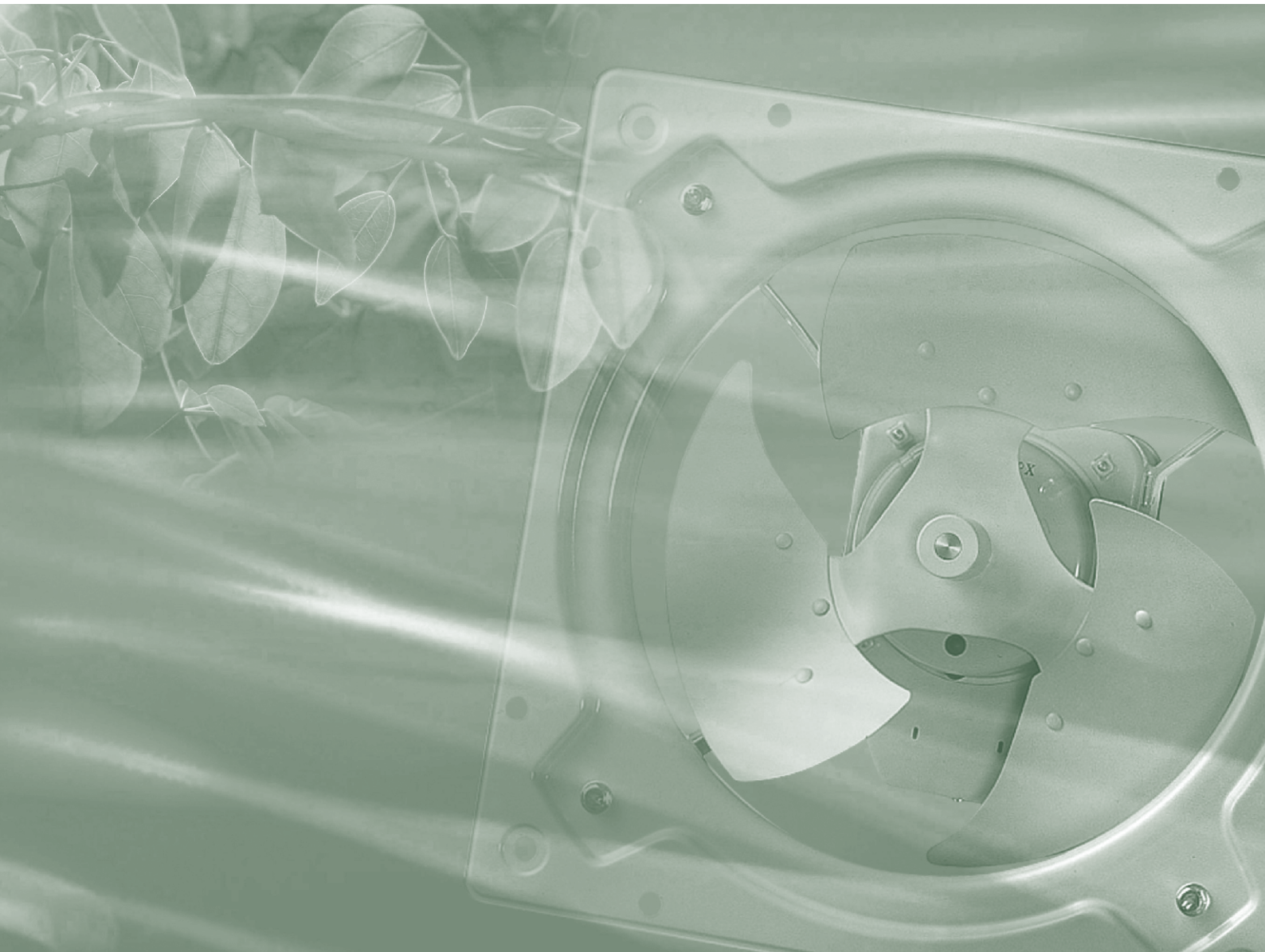

INDEX

General

P.3

**Standard Type
PF**

P.5



**Outdoor Type
WP**

P.14



**Pressure-Resistant Explosion-Proof
Motor Type
EPP**

P.19



**Stainless Steel Type
PFS**

P.24



**All Stainless Steel Type
WPS**

P.26



**Frameless Type
TP**

P.28



**Centrifugal Contact Type
S**

P.30



**Options
Compatibility Table**

P.32

**Options
Mounting Frames**

P.36



**Options
Fixed Louvers**

P.36



**Options
Wind Pressure Shutters**

P.37



**Options
Motor-Driven Shutters**

P.37



**Options
Outdoor Hoods**

P.39



**Options
Fireproof Hoods**

P.39



**Options
Intake Outdoor Hoods
(with rainwater gutter)**

P.40



**Options
Guard net**

P.41



**Options
Filter Unit**

P.43



Model Development Table

P.44

Low Noise Pressure Fans

Low noise type that meets the needs of the times

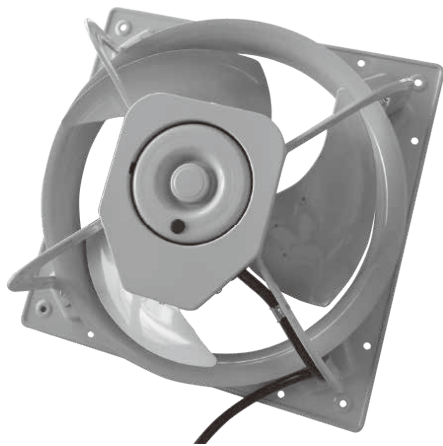

1 Low Noise Design

Performs large-scale fluid analysis of the entire pressure fan, high-performance silent type impeller shape is optimally designed.

2 Space Saving

Highly reputable low-profile conventional design. Compatible with replacement demand provided with mounting compatibility with existing products.

3 Long Life

High-grade urea-based grease excellent in water resistance and heat resistance adopted as standard. Expected design lifetime of 60,000 hrs. (when continuously operated at 50 °C).

*Only applicable to N series (series code: N).

Comparison with Existing Model

● Air Volume Comparison (30cm) *At a frequency of 60Hz

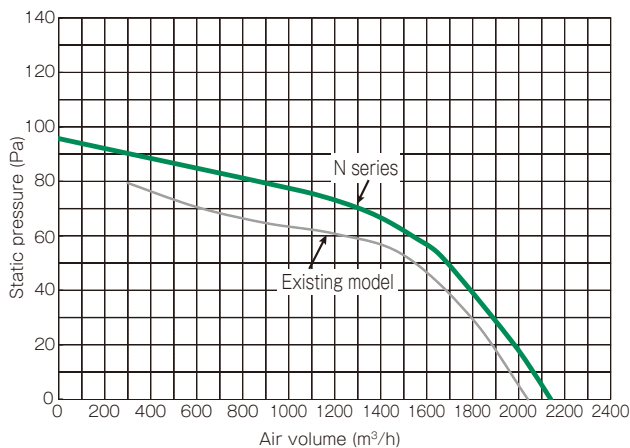

● Noise Comparison (30cm)

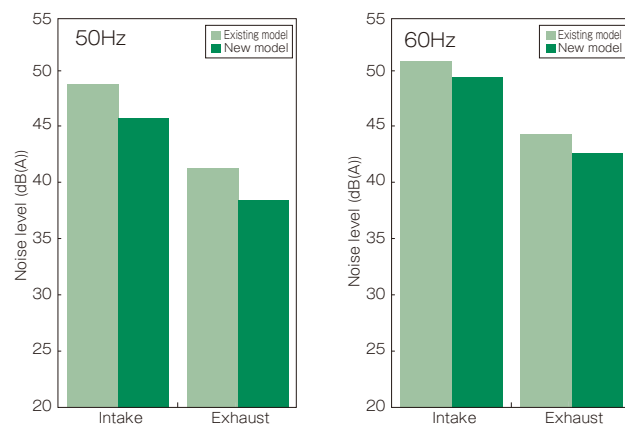

Line-Up of Pressure Fans

Standard type Exhaust Intake Impeller diameter: 20 to 120cm	Outdoor type Exhaust Intake Impeller diameter: 25 to 120cm	Pressure-resistant explosion-proof motor type Exhaust Intake Impeller diameter: 20 to 120cm	Stainless steel type Exhaust Intake Impeller diameter: 25 to 50cm
All stainless steel type Exhaust Impeller diameter: 30 to 40cm	Frameless type Exhaust Impeller diameter: 30 to 45cm	Centrifugal contact type Exhaust Impeller diameter: 25 to 60cm	

Description of types

A model code is assigned to each model of our pressure fans in accordance with the descriptions below. When contacting us, please specify the model code and the voltage used. (For any information not included in the descriptions below, please contact us.)

PF - 14 B T 2 N

⑦ ① ② ③ ④ ⑤ ⑥ ⑧

- ① Model type PF: Standard type (different voltage type)/PFS: Stainless steel type/ EPP: Pressure-resistant explosion-proof motor type/WP: Outdoor type/ WPS: All stainless steel type/TP: Frameless type/S: Centrifugal contact type
- ② Impeller nominal diameter Indicated in inches; For a value in centimeters, multiply the value in inches by 2.5.
- ③ Airflow direction B: Exhaust/A: Intake
* When facing the front of the impeller, exhaust air flows frontward, and intake air flows backward.
- ④ Power supply S: Single-phase/T: Three-phase
- ⑤ Voltage 1: 100 volt class/2: 200 volt class/4: 400 volt class
- ⑥ Series code Ascending alphabetical order
- ⑦ Number of poles None: Standard/Number specified: Multiple-pole type (6: six poles, 8: eight poles)
- ⑧ ID code None, 1, 2...

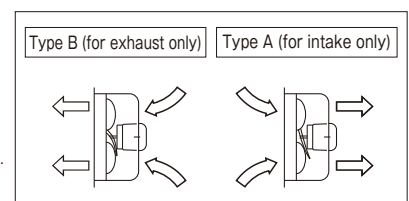

Handling Precautions

- 1** Install the pressure fan at a height of 1.8 meters or more from the floor surface. Failure to do so may cause injuries or accidents. In the case of installing it at a height of 1.8 meters or less, use the optionally available guard net.
- 2** Make sure that the metallic part of the main unit of the pressure fan does not come in direct contact with any building finished with metal lath, wire lath or metal. Any contact may cause an electric leakage, electric shock or fire.
- 3** Make sure to observe the operating ambient temperature and the humidity range. Any excess over the setting range of the specific model may result in burning, deformation or breakage.
- 4** For any model equipped with a ground wire, make sure to ground it.
- 5** Some models come with a drain plug attached to the motor. When such a model is used outdoors or in a place with high humidity, install it so that the drain plug is under the motor and remove the lower drain plug before use.
- 6** Install the pressure fan at any sturdy position where no vibration occurs. If the position of installation has insufficient strength, the fan may cause resonance that damages the blade or causes other type of accident. If it is installed at any position that is considered weak, add some reinforcement and install it firmly.
- 7** Some motors may have built-in thermal protectors so that they will automatically be halted in the event of constraint, overload or open-phase operation or if the ambient temperature is outside the operating range. In this case, power off the fan immediately, remedy the cause and wait until the motor cools down before resuming the operation.
- 8** Mounting position
The standard product is mounted so that the fan shaft is horizontal. For other mounting positions, please contact us.

- 9** For installation
For installation of the main unit of the pressure fan and combination with optional accessories, please refer to the diagram below.

Outdoor hood (optional accessory)

- Install it if the fan will be exposed to rain and wind.

Shutter and fixed louver

- For preventing intrusion of wind and rain, it is recommended to attach a shutter.

1 Mount the embedded bolt (commercially available).

2 Attach the main unit of the pressure fan.

- Fix it with four washers, four spring washers (commercially available) and then four hexagon nuts (commercially available).

3 Remove the drain caps (on the back side of the motor and the bottom surface) and others.

- Make sure to remove them in a place with high humidity.

Guard net (optional accessory)

- Make sure to attach it if the fan is installed at a height of 1.8 meters or less.

Impeller diameter

Impeller diameter	A	B	C	Bolt diameter	Impeller diameter	A	B	C	Bolt diameter
20cm	220	246	162	M6	50cm	563	620	355	M12
25cm	275	298	165	M6	60cm	664	720	400	M12
30cm	325	349	210	M6	75cm	825	900	508	M16
35cm	400	434	250	M10	90cm	980	1040	610	M16
40cm	450	485	280	M10	105cm	1132	1207	656	M16
45cm	494	540	320	M10	120cm	1345	1425	800	M16

(For any fan with a diameter of 90cm or more, fix it with bolts and nuts at eight positions.)

- 10** Use a motor breaker (overload protector) or equivalent as a protection circuit. Choose a motor breaker with around 1.2 times to 1.5 times the allowable current level of the specific fan for the purpose of prevention of malfunction.

- 11** The diagrams below illustrate connections of power lead wires.

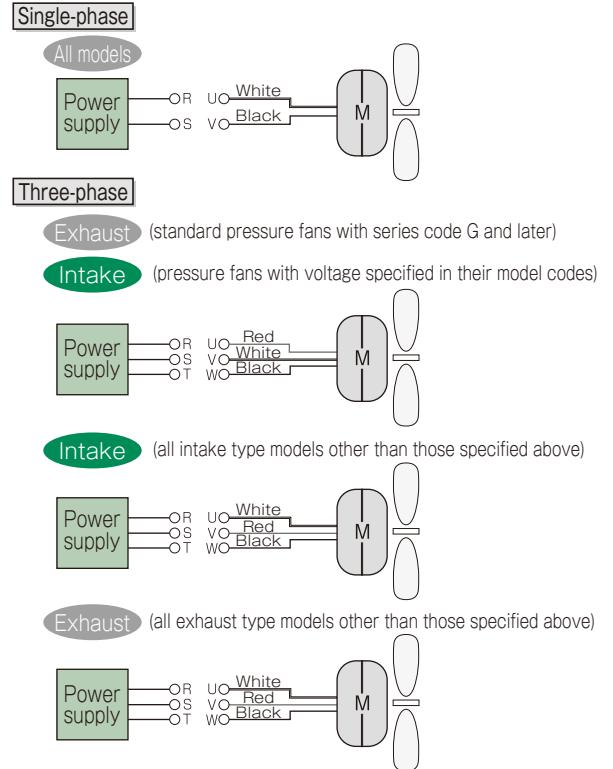

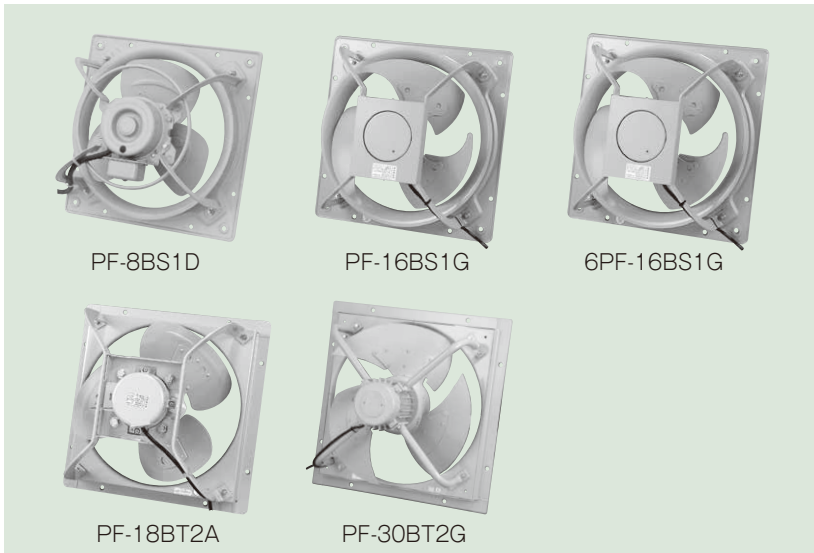

* Please note that the photo shows typical examples and that they may partly differ from actual items.

Applications

For ventilation, air intake into and air exhaust from factories and warehouses and incorporating into equipment

Specification table

Airflow direction	Model	Impeller diameter (cm)	Number of poles (P)	Power supply (V)	Nominal output (W)	Air volume (m ³ /h)		Power consumption (W)		Allowable current (A)		Starting current (A)		Noise (dB(A))		Approx. mass (kg)
						50Hz	60Hz	50Hz	60Hz	50Hz	60Hz	50Hz	60Hz	50Hz	60Hz	
Exhaust type	PF-8BS1D	20	4	Single-phase100	15	552	654	40	40	0.6	0.5	1.4	1.4	38	41	3.3
	PF-8BS2D			0.3						0.25	0.7	0.7				
	PF-10BS1N	25	Single-phase100	20	1204	1399	44	51	0.7	0.8	1.7	1.6	35.4	39.3	3.5	
	PF-10BS2N		0.4						0.5	0.9	1.0					
	PF-12BS1N	30	4	Single-phase100	50	1873	2140	61	90	0.9	1.2	1.9	1.7	39.1	42.8	5.4
	PF-12BS2N			0.5						0.6	0.8	0.7				
	PF-12BT2N			0.7						0.6	1.0	0.9				
	PF-14BS1N	35	4	Single-phase100	100	2831	3231	145	182	2.3	2.6	5.0	4.7	43.2	46.0	9.2
	PF-14BS2N			1.2						1.4	2.8	2.7				
	PF-14BT2N			1.3						1.7	1.0	2.7				
	PF-16BS1G	40	4	Single-phase100	200	4080	4680	188	240	3.5	3.45	8.3	7.9	46	50	11
	PF-16BS2G			2.0						1.8	4.3	4.2				
	PF-16BT2G			400		4022	4543	162	227	1.2	1.2	4.1	3.9			
	PF-16BT2F					4990	5790	300	420	2.3	2.5	8.3	6.3	57	61	12.3
	6PF-16BS1G	45	6	Single-phase100	100	2880	3340	86	101	1.4	1.6	2.8	2.6	40	44	10.8
	6PF-16BS2G			0.72						0.84	1.6	1.6				
	6PF-16BT2G			0.9						0.9	2.2	2.1				
	PF-18BS1A	45	6	Single-phase100	250	5010	5838	230	340	5.5	7.5	11	11	54	58	23.5
	PF-18BS2A			2.7						3.7	6.5	5.9				
	PF-18BT2A			5034		5802	210	310	2.3	3.0	6.5	5.7				
	PF-20BS1G	50	6	Single-phase100	400	6200	7020	300	450	7.0	7.2	11	11	49	53	25
	PF-20BS2G			3.5						3.6	6.5	5.9				
	PF-20BT2G			6120		7140	270	410	2.6	2.8	6.5	5.7				
	PF-24BT2G	60	8	Three-phase200	750	9420	11160	460	690	4.2	4.2	12	10	51	55.5	33
	8PF-24BT2G				400	7060	8360	250	330	3.0	3.0	5.8	4.6	45	49.5	33
	PF-30BT2G	75	6	1500	19500	19500	1500	1640	7.7	6.7	33	29	62	64	77.5	
	PF-36BT2G	90	8	Three-phase200	2200	27000	27000	2050	2250	11.0	11.0	38	34	69	73	86
	8PF-36BT2				1500	22800	22800	850	1200	6.7	6.2	25	23	71	74	76
	PF-42BT2G	105	8	2200	36000	36000	2050	2600	14	15.0	42	35	67	71	118	
	PF-48B	120	10	3700	42000	42000	3200	3200	20	17	74	63	75	76	153	

- The power consumption, air volume and noise figures mentioned above represent the values in the state of operation under free air conditions.
- The air volume has been measured using the JIS C 9603-compliant orifice chamber method, except for models where an impeller diameter ranges from 90cm to 120cm, for which the JIS B 8330-compliant suction pipe method was employed.
- The noise figure represents the average of the values measured at three points that are 1.5 meters distant from one another. The value in actual operation varies depending on the installation method, the duct form, and so on.
- The allowable current figure represents the critical point of operation. Use it for reference at the time of selecting a motor breaker.
- Make sure that the product is used in a place where no corrosive or explosive gas or no steam is generated.
- Environment conditions (temperature and humidity) where the fan is installed are as follows. Observe these conditions when using the product.

- Single-phase power supply models
 - Impeller diameter 35cm or less: Temperature from -30 to +50 °C, humidity 90% or less, elevation 1,000m or less
 - Impeller diameter 40cm with four poles: Temperature from -20 to +50 °C, humidity 90% or less, elevation 1,000m or less
 - Impeller diameter 40cm or more with six poles: Temperature from -10 to +50 °C, humidity 85% or less, elevation 1,000m or less
- Three-phase power supply models
 - Temperature from -30 to +50 °C, humidity 85% or less*, elevation 1,000m or less
 - * For models with the impeller diameter 40cm or less and with four poles, the humidity must be 90% or less.

Specification table

Airflow direction	Model	Impeller diameter (cm)	Number of poles (P)	Power supply (V)	Nominal output (W)	Air volume (m³/h)		Power consumption (W)		Allowable current (A)		Starting current (A)		Noise (dB(A))		Approx. mass (kg)				
						50Hz	60Hz	50Hz	60Hz	50Hz	60Hz	50Hz	60Hz	50Hz	60Hz					
Intake type	PF-8AS1D	20	4	Single-phase100	15	546	642	40	40	0.6	0.5	1.4	1.4	38	42	3.3				
	Single-phase200			0.3						0.25	0.7	0.7								
	PF-10AS1N	25	4	Single-phase100	20	1024	1206	43	50	0.8	0.9	1.7	1.6	39.5	44.3	3.5				
	Single-phase200			0.5						0.5	0.9	0.9								
	PF-12AS1N	30	4	Single-phase100	50	1654	1873	67	96	1.1	1.4	1.9	1.7	45.6	49.7	5.4				
	Single-phase200			0.6						0.6	0.8	0.7								
	PF-12AT2N			Three-phase200						1678	1902	71	102				0.5	0.5	1.0	0.9
	PF-14AS1N			Single-phase100						100	2540	2868	150				193	2.4	2.9	5.0
	PF-14AS2N	Single-phase200	156	201	1.3	1.5	2.8	2.7												
	PF-14AT2N	Three-phase200	139	184	1.1	1.1	2.9	2.7												
	PF-16AS1D	Single-phase100	200	3528	4008	210	270	3.15	3.4				8.3	7.9						
	PF-16AS2D	Single-phase200				204	260	1.7	1.7	4.3	4.2									
	PF-16AT2D	Three-phase200				3600	4140	184	263	1.14	1.14	4.1	3.9							
	6PF-16AS1D	Single-phase100				400	4745	5568	305	460	2.3	2.5	8.3	6.3						
	6PF-16AS2D	Single-phase200	90	107	1.5				1.6	2.8	2.6									
	6PF-16AT2D	Three-phase200	2442	2832	102				120	0.75	0.75	1.6	1.6							
	PF-18AS1A	Single-phase100	250	3906	4530				250	370	5.8	6.7	11	11						
	PF-18AS2A	Single-phase200				250	370	2.9	3.4	6.5	5.9									
	PF-18AT2A	Three-phase200				3920	4600	230	340	2.3	3.0	6.5	5.7							
	PF-20AS1A	Single-phase100				400	5280	6120	270	400	6.5	6.8	11	11						
	PF-20AS2A	Single-phase200	270	400	3.2				3.4	6.5	5.9									
	PF-20AT2A	Single-phase200	5220	6000	250				340	2.7	3.0	6.5	5.7							
	PF-24AT2G	75	6	Three-phase200	750				6360	7380	490	710	4.1	4.1	12	10	55.5	59	33	
	8PF-24AT2G	60	8	Three-phase200	400	5420	6280	270	360	3.0	2.8	5.8	4.6	48.5	52	33				
PF-30AT2G	75	6	Three-phase200	1500	15000	15000	1380	1600	7.4	7.8	33	29	68	69	81					
8PF-36AT2	90	8	Three-phase200	1500	22800	22800	1040	1040	6.4	6.1	25	23	71	74	76					
PF-42AT2	105	8	Three-phase200	2200	34200	34200	2500	2260	11.4	10.3	42	35	74	76	103					
PF-48A	120	10	Three-phase200	3700	42000	42000	3200	3200	20	17	74	63	75	76	153					

- The power consumption, air volume and noise figures mentioned above represent the values in the state of operation under free air conditions.
- The air volume has been measured using the JIS C 9603-compliant orifice chamber method, except for models where an impeller diameter ranges from 90cm to 120cm, for which the JIS B 8330-compliant suction pipe method was employed.
- The noise figure represents the average of the values measured at three points that are 1.5 meters distant from one another. The value in actual operation varies depending on the installation method, the duct form, and so on.
- The allowable current figure represents the critical point of operation. Use it for reference at the time of selecting a motor breaker.
- Make sure that the product is used in a place where no corrosive or explosive gas or no steam is generated.
- Environment conditions (temperature and humidity) where the fan is installed are as follows. Observe these conditions when using the product.

Single-phase power supply models
 Impeller diameter 35cm or less: Temperature from -30 to +50 °C, humidity 90% or less, elevation 1,000m or less
 Impeller diameter 40cm with four poles: Temperature from -20 to +50 °C, humidity 90% or less, elevation 1,000m or less
 Impeller diameter 40cm or more with six poles: Temperature from -10 to +50 °C, humidity 85% or less, elevation 1,000m or less
 Three-phase power supply models
 Temperature from -30 to +50 °C, humidity 85% or less*, elevation 1,000m or less
 * For models with the impeller diameter 40cm or less and with four poles, the humidity must be 90% or less.

Special Specifications

Impeller diameter (cm)	Airflow direction	Special order features						
		Different voltage 210V or 215V	Different voltage 400V	Heat resistance of 60 °C	Heat resistance of 80 °C	Acid-resistant (salt-resistant) coating	Specified color	MFP treatment
20	Exhaust	×	×	×	×	○	○	×
	Intake	×	×	×	×	○	○	×
25	Exhaust	×	×	×	×	○	○	×
	Intake	×	×	×	×	○	○	×
30	Exhaust	×	*1	×	×	○	○	×
	Intake	×	*1	×	×	○	○	×
35	Exhaust	×	*1	*2	*2	○	○	×
	Intake	×	*1	*2	*2	○	○	×
40	Exhaust	○	*1	*2	*2	○	○	*3
	Intake	○	*1	*2	*2	○	○	*3
45	Exhaust	○	*1	○	○	○	○	○
	Intake	○	*1	○	○	○	○	○
50	Exhaust	○	*1	○	○	○	○	○
	Intake	○	*1	○	○	○	○	○
60	Exhaust	○	○	○	○	○	○	○
	Intake	○	○	○	○	○	○	○
75	Exhaust	○	○	○	○	○	○	○
	Intake	○	○	○	○	○	○	○
90	Exhaust	○	○	○	○	○	○	○
	Intake	○	○	○	○	○	○	○
105	Exhaust	○	○	○	○	○	○	○
	Intake	○	○	○	○	○	○	○
120	Exhaust	○	○	○	○	○	○	○
	Intake	○	○	○	○	○	○	○

- *1: 400V class available for three-phase power supply models only
- *2: Heat resistance feature available for three-phase power supply models only
- *3: MFP treatment available for three-phase power supply models only

Selection chart

[Exhaust type]

Single-phase, impeller diameter from 20 to 40cm, four poles

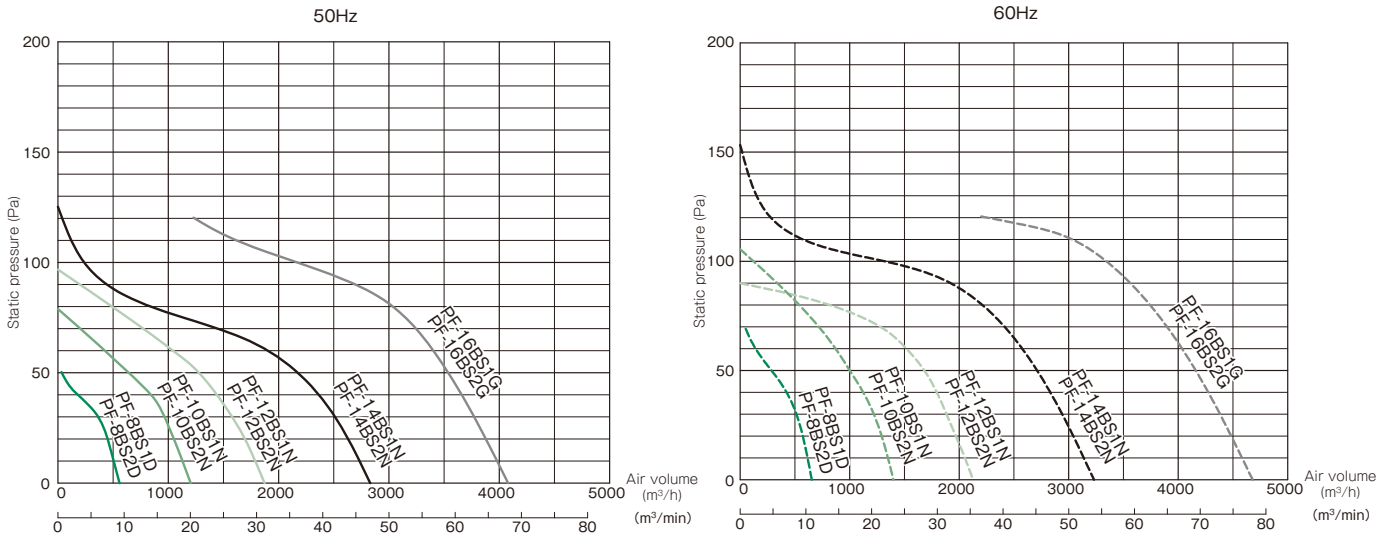

Single-phase, impeller diameter from 40 to 50cm, six poles

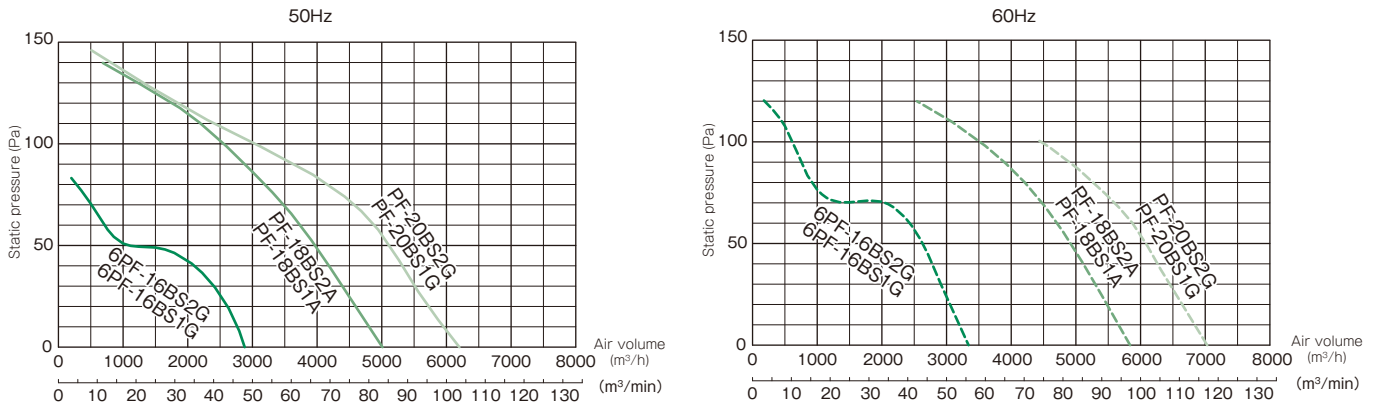

Three-phase, impeller diameter from 30 to 40cm, four poles

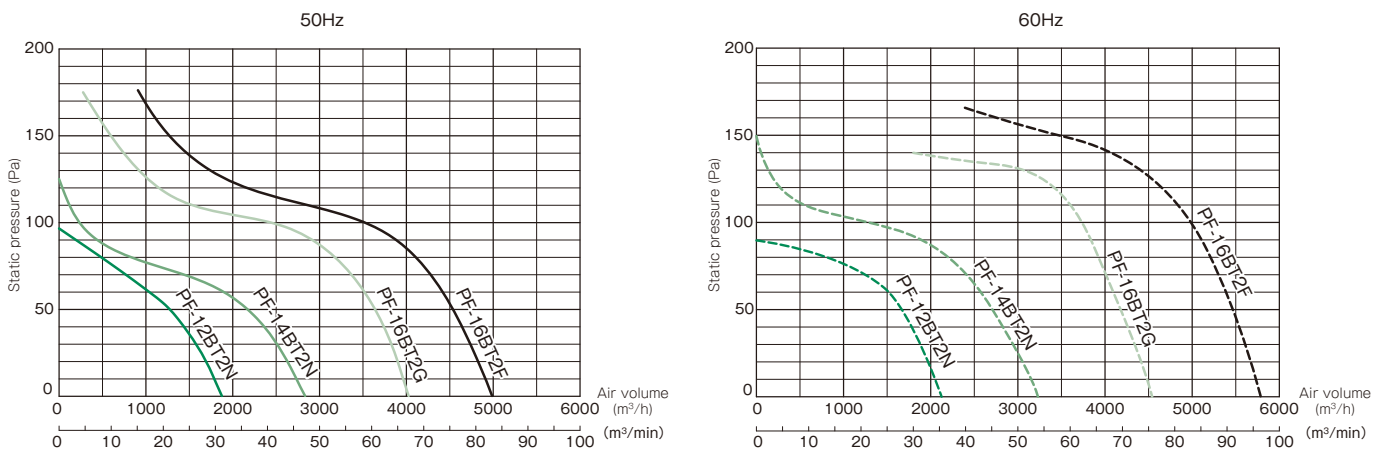

Three-phase, impeller diameter from 40 to 60cm, six poles

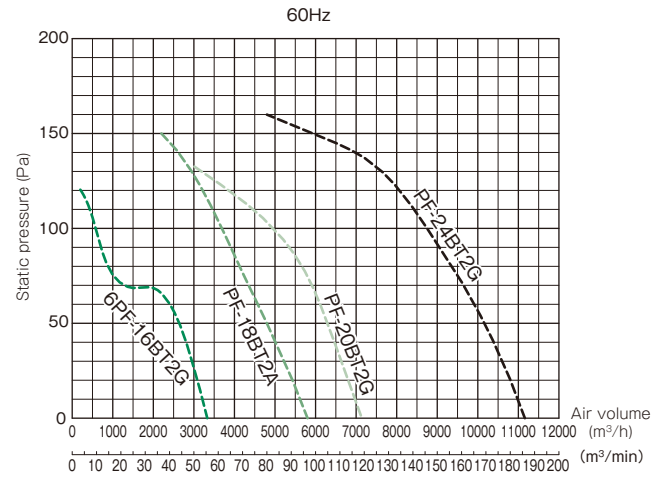
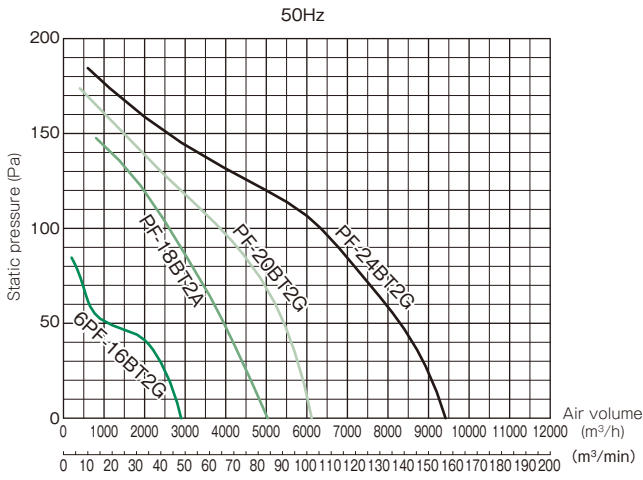

Three-phase, impeller diameter 60cm, eight poles; impeller diameter from 75 to 120cm

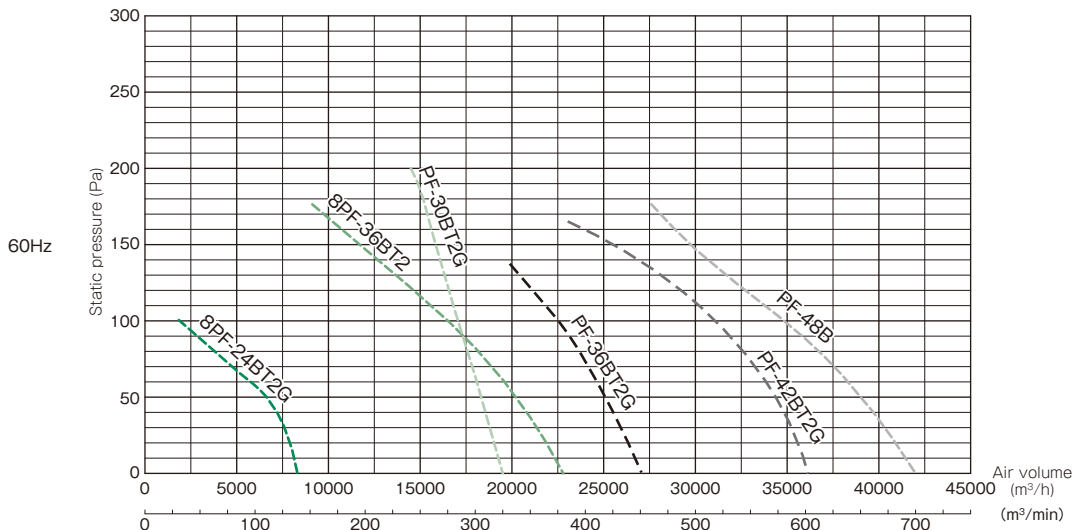
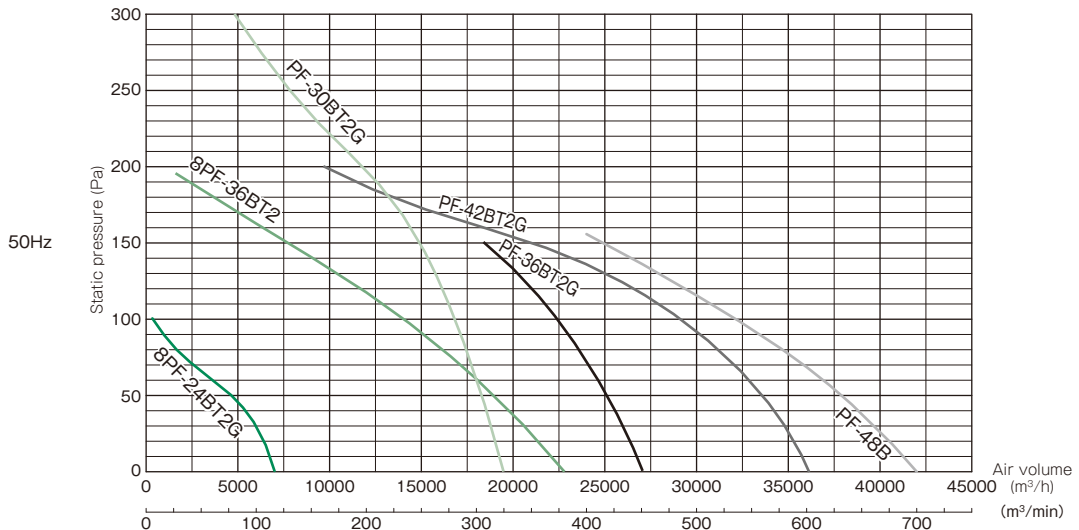

Selection chart

[Intake type]

Single-phase, impeller diameter from 20 to 40cm, four poles

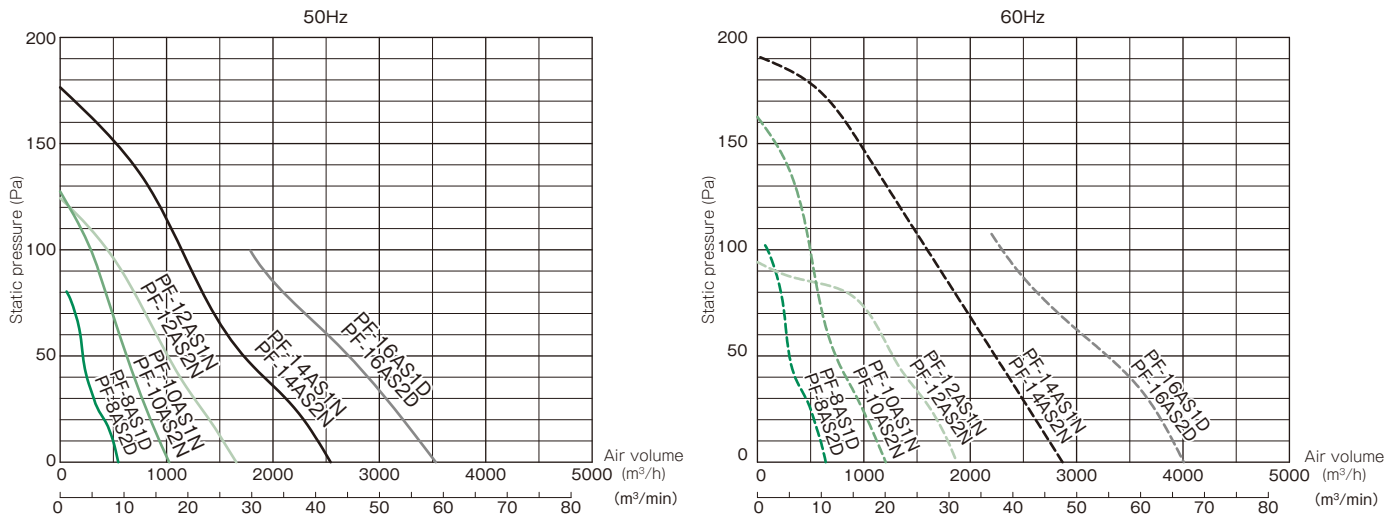

Single-phase, impeller diameter from 40 to 50cm, six poles

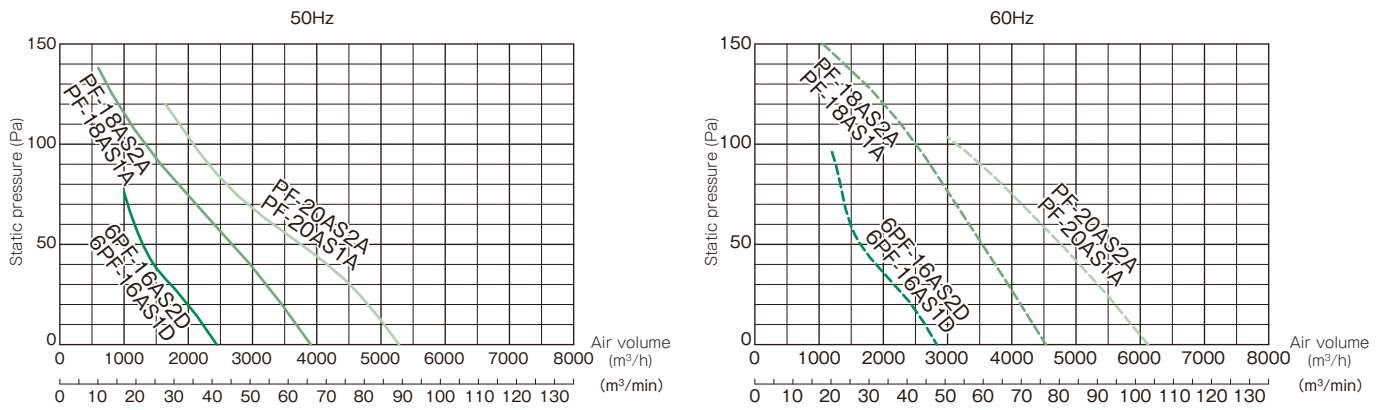

Three-phase, impeller diameter from 30 to 40cm, four poles

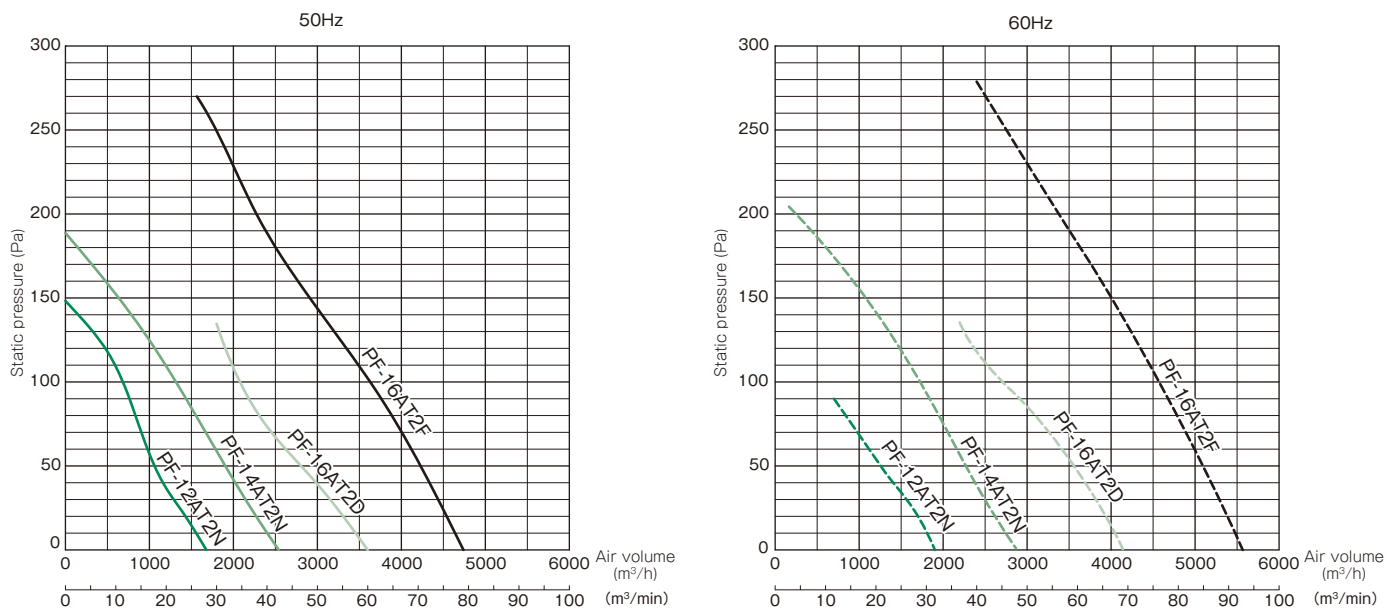

Three-phase, impeller diameter from 40 to 60cm, six poles

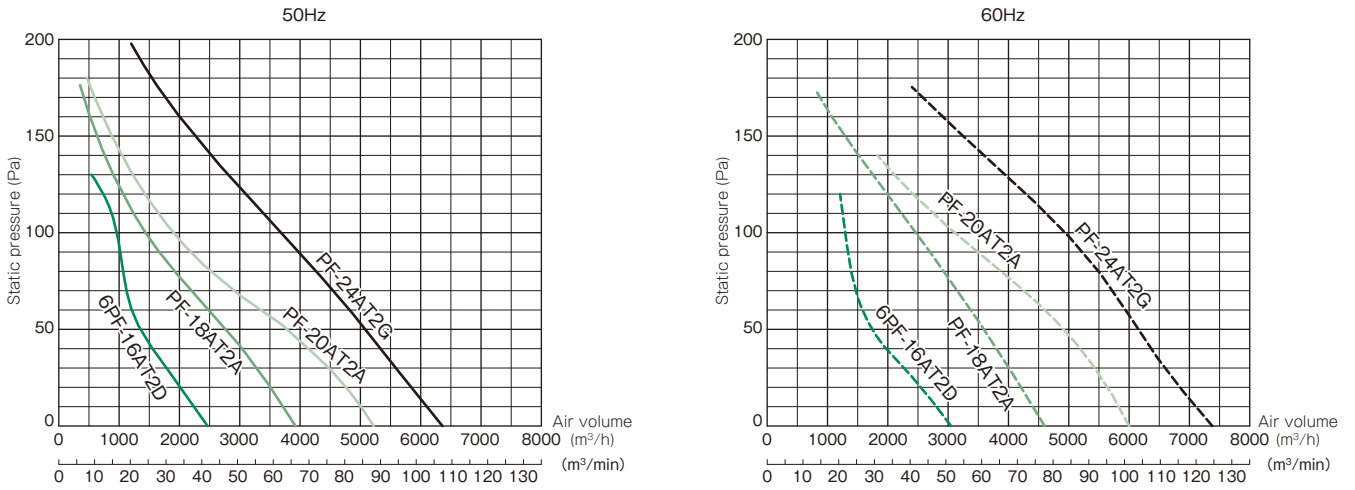

Three-phase, impeller diameter 60cm, eight poles; impeller diameter from 75 to 120cm

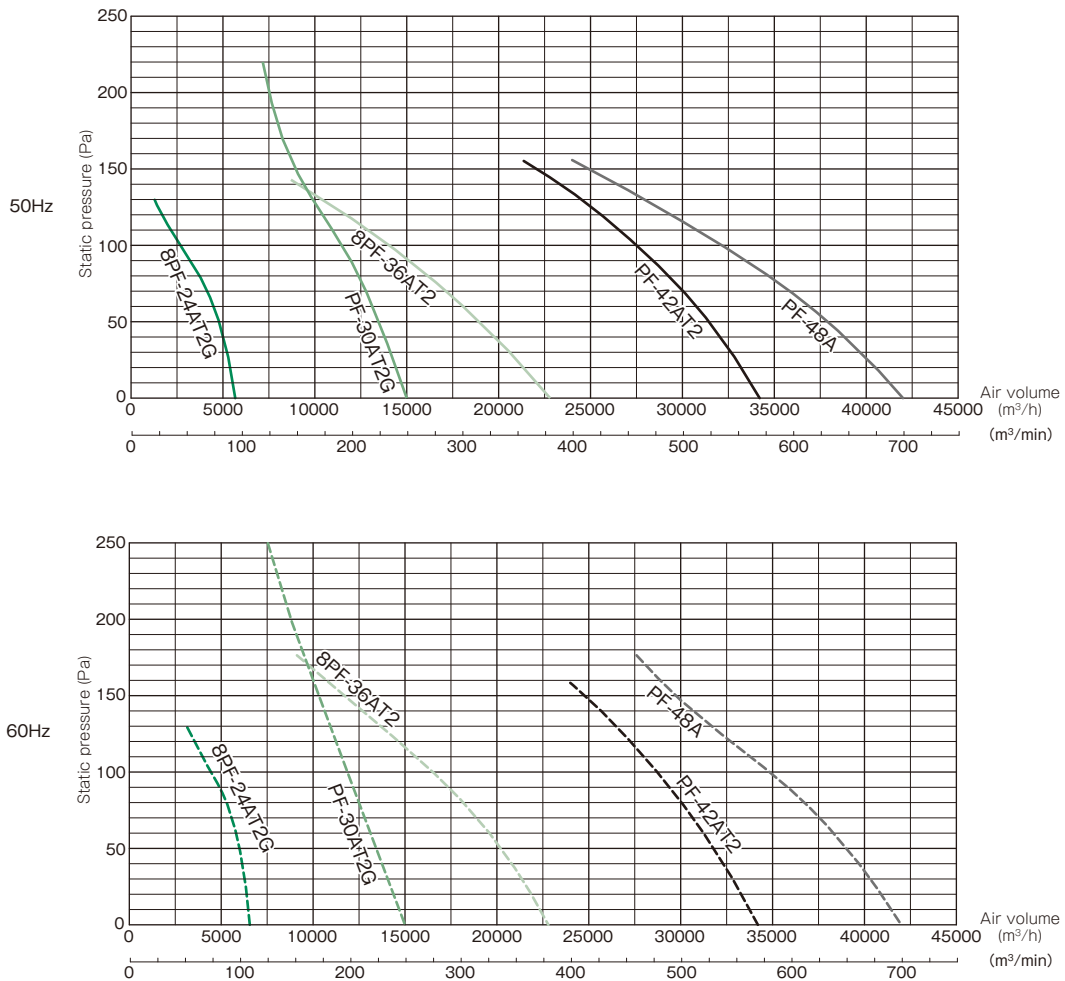

■ Assembly drawing [Exhaust Type]

* For intake type, please contact us.

impeller diameter from 20 to 40cm, four poles

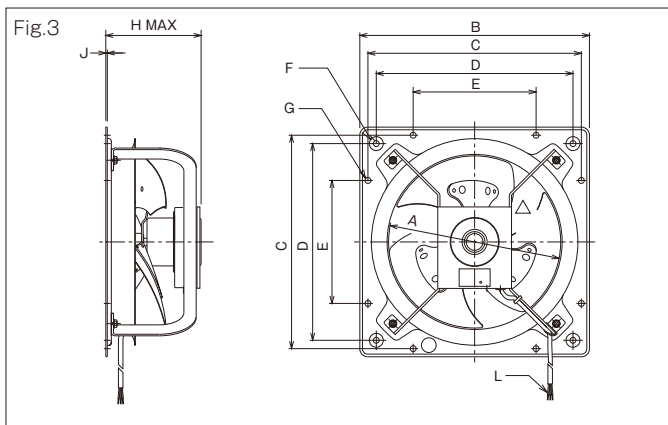
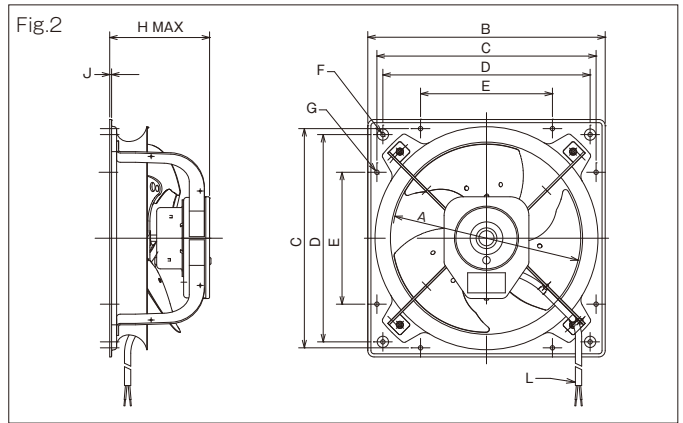
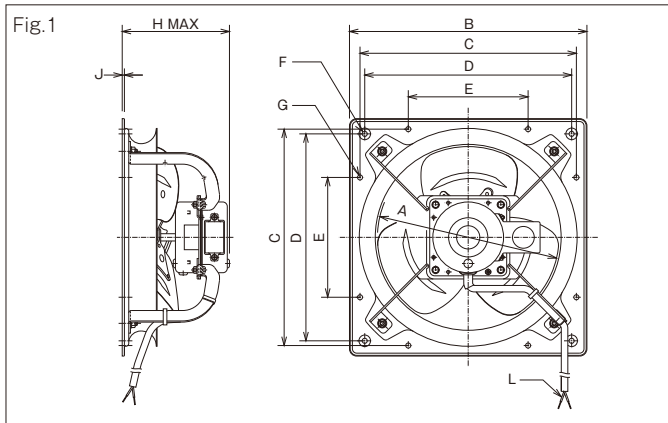

* The shape varies slightly depending on the model.

■ Dimensions

(Unit:mm)

Fig.	Model	A	B	C	D	E	F	G	H	J	L
1	PF-8BS1D	200	276	246	240	162	4×φ7	8×φ7	147.5	3	Heat-resistant vinyl-insulated wire×2×0.75mm ² ×1m
	PF-8BS2D	200	276	246	240	162	4×φ7	8×φ7	147.5	3	Heat-resistant vinyl-insulated wire×2×0.75mm ² ×1m
2	PF-10BS1N	260	327	298	285	165	4×φ7	8×φ7	147.7	3	Heat-resistant vinyl-insulated wire×2×0.75mm ² ×1m
	PF-10BS2N	260	327	298	285	165	4×φ7	8×φ7	147.7	3	Heat-resistant vinyl-insulated wire×2×0.75mm ² ×1m
	PF-12BS1N	300	378	349	330	210	4×φ7	8×φ7	159	3	VCT×2 cores×0.75mm ² ×1m
	PF-12BS2N	300	378	349	330	210	4×φ7	8×φ7	159	3	VCT×2 cores×0.75mm ² ×1m
	PF-12BT2N	300	378	349	330	210	4×φ7	8×φ7	159	3	VCT×3 cores×0.75mm ² ×1m
	PF-14BS1N	350	467	434	400	250	4×φ12	8×φ12	194	3	VCT×2 cores×0.75mm ² ×1m
	PF-14BS2N	350	467	434	400	250	4×φ12	8×φ12	194	3	VCT×2 cores×0.75mm ² ×1m
3	PF-14BT2N	350	467	434	400	250	4×φ12	8×φ12	194	3	VCT×3 cores×0.75mm ² ×1m
	PF-16BS1G	400	518	485	450	280	4×φ12	8×φ12	198	3	2PNCT×2 cores×0.75mm ² ×1m
	PF-16BS2G	400	518	485	450	280	4×φ12	8×φ12	198	3	2PNCT×2 cores×0.75mm ² ×1m
	PF-16BT2G	400	518	485	450	280	4×φ12	8×φ12	198	3	2PNCT×3 cores×0.75mm ² ×1m
	PF-16BT2F	400	518	485	450	280	4×φ12	8×φ12	224	3	2PNCT×3 cores×1.25mm ² ×1m

Assembly drawing [Exhaust Type]

* For intake type, please contact us.

impeller diameter from 40 to 60cm, six poles

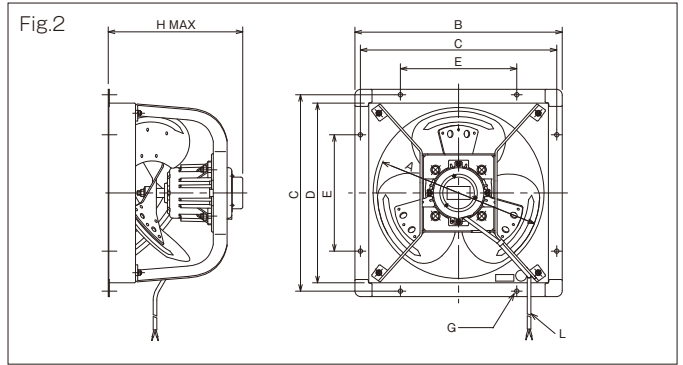
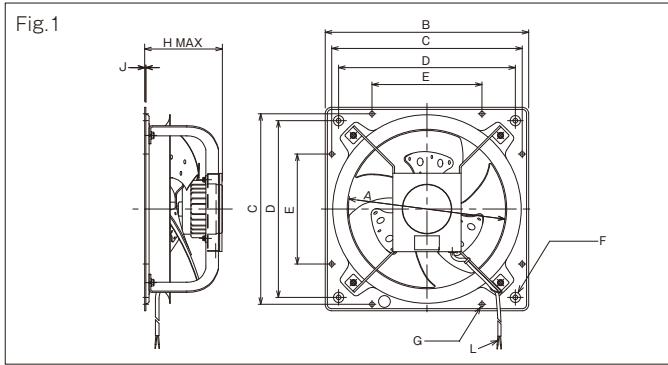

* The shape varies slightly depending on the model.
(Unit:mm)

Dimensions

Fig.	Model	A	B	C	D	E	F	G	H	J	L
1	6PF-16BS1G	400	518	485	450	280	4×φ12	8×φ12	198	3	2PNCT×2 cores×0.75mm ² ×1m
	6PF-16BS2G	400	518	485	450	280	4×φ12	8×φ12	198	3	2PNCT×2 cores×0.75mm ² ×1m
	6PF-16BT2G	400	518	485	450	280	4×φ12	8×φ12	198	3	2PNCT×3 cores×0.75mm ² ×1m
2	PF-18BS1A	450	570	540	494	320	/	8×φ12	380	/	2PNCT×2 cores×1.25mm ² ×1m
	PF-18BS2A	450	570	540	494	320	/	8×φ12	380	/	2PNCT×2 cores×1.25mm ² ×1m
	PF-18BT2A	450	570	540	494	320	/	8×φ12	350	/	2PNCT×3 cores×1.25mm ² ×1m
	PF-20BS1G	500	659	620	563	355	/	8×φ15	395	/	2PNCT×2 cores×1.25mm ² ×1m
	PF-20BS2G	500	659	620	563	355	/	8×φ15	395	/	2PNCT×2 cores×1.25mm ² ×1m
	PF-20BT2G	500	659	620	563	355	/	8×φ15	365	/	2PNCT×3 cores×1.25mm ² ×1m
	PF-24BT2G	600	760	720	664	400	/	8×φ15	380	/	2PNCT×3 cores×1.25mm ² ×1m

impeller diameter 60cm, eight poles; impeller diameter from 75 to 120cm

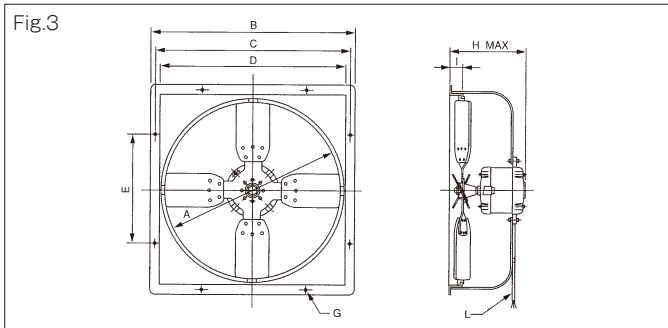
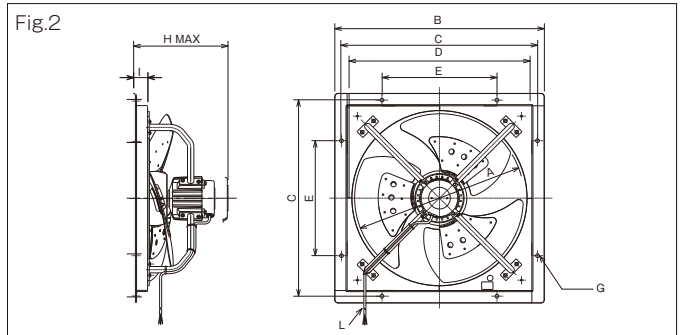
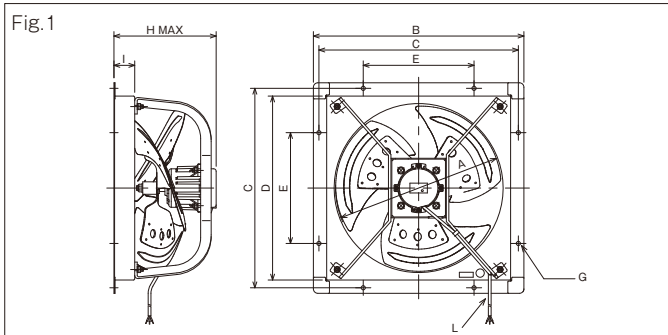

* The shape varies slightly depending on the model.

Dimensions

(Unit:mm)

Fig.	Model	A	B	C	D	E	F	G	I	L
1	8PF-24BT2G	600	760	720	664	400	8×φ15	380	75	2PNCT×3 cores×1.25mm ² ×1m
	PF-30BT2G	750	955	900	825	508	8×φ20	450	65	2PNCT×3 cores×2mm ² ×1m
2	PF-36BT2G	900	1110	1040	980	610	8×φ20	440	65	2PNCT×3 cores×2mm ² ×1m
3	8PF-36BT2	900	1110	1040	980	610	8×φ20	415	65	2PNCT×3 cores×2mm ² ×1m
2	PF-42BT2G	1050	1262	1207	1132	656	8×φ20	560	65	2PNCT×3 cores×3.5mm ² ×1m
3	PF-48B	1200	1475	1425	1345	800	8×φ20	540	/	2PNCT×3 cores×5.5mm ² ×3m

Special Accessory

Intake Attachment

Make sure to use it when using the PF-16AT2F (intake type pressure fan) in combination with a motor-driven shutter.

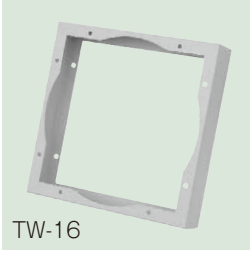

TW-16

* Please note that the photo shows a typical example and that it may partly differ from the actual item.

Assembly drawing

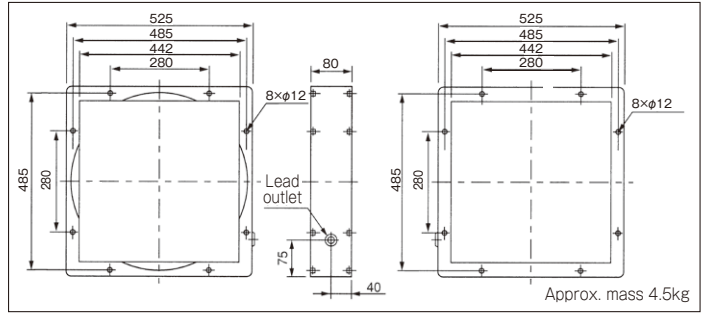

Example of Combination

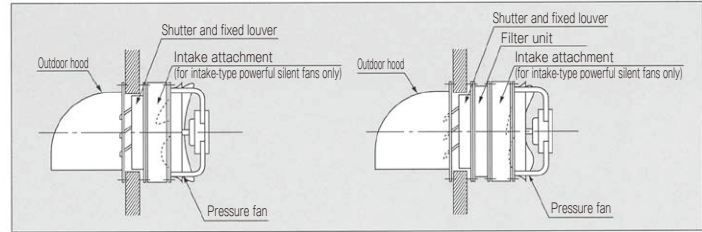

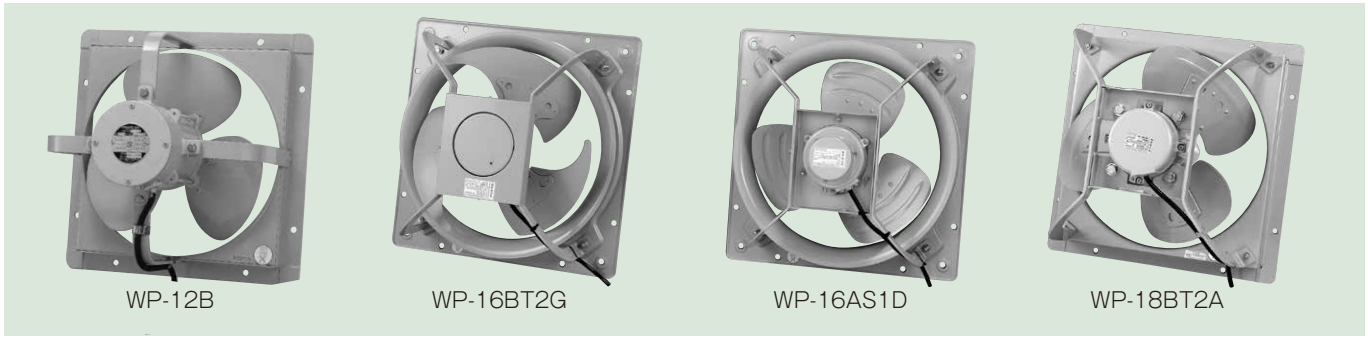

* Please note that the photo shows a typical example and that it may partly differ from the actual item.

Applications

For installation in a place with high humidity and outdoors

Feature

These pressure fans are equipped with outdoor motors suited for conditions of high humidity.

Notes on Installation

- Any model with the impeller diameter 35cm or more has a drain hole underneath the motor. (For installing the fan with the motor shaft positioned horizontally), make sure that the drain hole faces downward. When using it outdoors or under conditions of high humidity, remove the drain hole cap facing downward. When using it in any dusty place or when water comes into the fan, keep the cap attached and detach it occasionally to perform an inspection.
- It is standard to install the fan with the shaft positioned horizontally. If it is installed in a non-standard manner (e.g. at an attitude in which the shaft faces downward), make sure to specify it at the time of placing an order. Installation of any fan designed to be installed in the standard manner at an attitude in which it faces downward may cause failure.

Specification table

Airflow direction	Model	Impeller diameter (cm)	Number of poles (P)	Power supply (V)	Nominal output (W)	Air volume (m³/h)		Power consumption (W)		Allowable current (A)		Starting current (A)		Noise (dB(A))		Approx. mass (kg)	
						50Hz	60Hz	50Hz	60Hz	50Hz	60Hz	50Hz	60Hz	50Hz	60Hz		
Exhaust type	WP-10B	25	4	Single-phase100	20	570	690	31	37	0.7	0.7	0.9	0.8	45	49	5.5	
				Single-phase200						0.35	0.35	0.5	0.4				
	WP-12B	30	4	Single-phase100	50	1446	1704	66	83	1.2	1.5	2.8	3	51	55	8.5	
				Single-phase200						0.6	0.75	1.4	1.5				
	WP-14BS1G	35	4	Single-phase100	100	2660	3150	142	144	3.2	3	8.3	7.9	43.5	47	9.4	
	WP-14BS2G			1.6						1.5	4.3	4.2					
	WP-14BT2G			102						122	1.25	1.15	4.1				3.9
	WP-16BS1G	40	4	Single-phase100	200	4080	4680	188	240	3.5	3.45	8.3	7.9	46	50	11	
	WP-16BS2G			200						250	1.8	1.8	4.3				4.2
	WP-16BT2G			4022						4543	162	227	1.2				1.2
	6WP-16BS1G	40	6	Single-phase100	100	2880	3340	86	101	1.4	1.6	2.8	2.6	40	44	10.8	
	6WP-16BS2G			98						116	0.72	0.84	1.6				1.6
	6WP-16BT2G			114						118	0.9	0.9	2.2				2.1
	WP-18BS1A	45	6	Single-phase100	250	5010	5838	230	340	5.5	7.5	11	11	54	58	23.5	
	WP-18BS2A			2.7						3.7	6.5	5.9					
	WP-18BT2A			5034						5802	210	310	2.3			3.0	6.5
	WP-20BS1G	50	6	Single-phase100	400	6200	7020	300	450	7.0	7.2	11	11	49	53	25	
	WP-20BS2G			3.5						3.6	6.5	5.9					
	WP-20BT2G			6120						7140	270	410	2.6			2.8	6.5
	WP-24BT2G	60	8	Three-phase200	750	9420	11160	460	690	4.2	4.2	12	10	51	55.5	33	
8WP-24BT2G	400				7060	8360	250	330	3.0	3.0	5.8	4.6	45	49.5			
WP-30BT2G	75	6	Three-phase200	1500	19500	19500	1500	1640	7.7	6.7	33	29	62	64	77.5		
WP-36BT2G	90	6		2200	27000	27000	2050	2250	11.0	11.0	38	34	69	73	86		
WP-42BT2G	105	8	Three-phase200	2200	36000	36000	2050	2600	14.0	15.0	42	35	67	71	118		
WP-48B	120	10		3700	42000	42000	3200	3200	20	17	74	63	75	76	153		

- The power consumption, air volume and noise figures mentioned above represent the values in the state of operation under free air conditions.
- The air volume has been measured using the JIS C 9603-compliant orifice chamber method, except for models where an impeller diameter ranges from 90cm to 120cm, for which the JIS B 8330-compliant suction pipe method was employed.
- The noise figure represents the average of the values measured at three points that are 1.5 meters distant from one another. The value in actual operation varies depending on the installation method, the duct form, and so on.
- The allowable current figure represents the critical point of operation. Use it for reference at the time of selecting a motor breaker.
- Make sure that the product is used in a place where no corrosive or explosive gas or no steam is generated.
- The fan should be installed in an environment where the temperature ranges from -10 °C to +40 °C, the humidity is 100% or less, and the elevation is 1,000m or less. Observe these conditions when using the product.

■ Specification table

Airflow direction	Model	Impeller diameter (cm)	Number of poles (P)	Power supply (V)	Nominal output (W)	Air volume (m³/h)		Power consumption (W)		Allowable current (A)		Starting current (A)		Noise (dB(A))		Approx. mass (kg)
						50Hz	60Hz	50Hz	60Hz	50Hz	60Hz	50Hz	60Hz	50Hz	60Hz	
Intake type	WP-10A	25	4	Single-phase100	20	402	498	31	37	0.7	0.7	0.9	0.8	45	49	5.5
										0.35	0.35	0.5	0.4			
	WP-12A	30	4	Single-phase100	50	720	840	66	83	1.2	1.5	2.8	3	51	55	8.5
										0.6	0.75	1.4	1.5			
	WP-14AS1D	35	4	Single-phase100	100	2484	2898	164	186	3.0	3.2	8.3	7.9	54	57	9.4
										1.6	1.7	4.3	4.2			
	WP-14AS2D	35	4	Single-phase200	100	2538	2904	120	160	1.15	1.1	4.1	3.9	54	57	9.4
	WP-14AT2D			Three-phase200						1.15	1.1	4.1	3.9			
	WP-16AS1D	40	4	Single-phase100	200	3528	4008	210	270	3.15	3.4	8.3	7.9	55	59	10.5
	WP-16AS2D			Single-phase200						210	270	3.15	3.4			
	WP-16AT2D	40	4	Three-phase200	200	3600	4140	184	263	1.14	1.14	4.1	3.9	55	59	10.5
	6WP-16AS1D			Single-phase100						90	107	1.5	1.6			
	6WP-16AS2D	40	4	Single-phase200	100	2442	2832	102	120	0.75	0.75	1.6	1.6	45	49	10.5
	6WP-16AT2D			Three-phase200						114	123	0.86	0.86			
	WP-18AS1A	45	6	Single-phase100	250	3906	4530	250	370	5.8	6.7	11	11	56	60	23.5
	WP-18AS2A			Single-phase200						29	3.4	6.5	5.9			23
	WP-18AT2A	45	6	Three-phase200	250	3920	4600	230	340	2.3	3.0	6.5	5.7	56	60	23
	WP-20AS1A			Single-phase100						6.5	6.8	11	11			24.5
	WP-20AS2A	50	6	Single-phase200	400	5280	6120	270	400	3.2	3.4	6.5	5.9	58	61	24.5
	WP-20AT2A			Single-phase200						2.7	3.0	6.5	5.7			24.3
WP-24AT2G	60	8	Three-phase200	750	6360	7380	490	710	4.1	4.1	12	10	55.5	59	33	
8WP-24AT2G									400	5420	6280	270	360	3.0		2.8
WP-30AT2G	75	6	Three-phase200	1500	15000	15000	1380	1600	7.4	7.8	33	29	68	69	81	
WP-30AT2					19500	19500	1580	1400	7.0	6.8	33	29	72	73	73.5	
WP-36AT2	90	6	Three-phase200	2200	27000	27000	1720	2200	8.6	9.0	31	28	77	80	76	
WP-42AT2	105	8			34200	34200	2500	2260	11.4	10.3	42	35	74	76	103	
WP-48A	120	10	3700	42000	42000	3200	3200	20	17	74	63	75	75	153		

- The power consumption, air volume and noise figures mentioned above represent the values in the state of operation under free air conditions.
- The air volume has been measured using the JIS C 9603-compliant orifice chamber method, except for models where an impeller diameter ranges from 90cm to 120cm, for which the JIS B 8330-compliant suction pipe method was employed.
- The noise figure represents the average of the values measured at three points that are 1.5 meters distant from one another. The value in actual operation varies depending on the installation method, the duct form, and so on.
- The allowable current figure represents the critical point of operation. Use it for reference at the time of selecting a motor breaker.
- Make sure that the product is used in a place where no corrosive or explosive gas or no steam is generated.
- The fan should be installed in an environment where the temperature ranges from -10 °C to +40 °C, the humidity is 100% or less, and the elevation is 1,000m or less. Observe these conditions when using the product.

■ Special Specifications

Impeller diameter (cm)	Airflow direction	Special order features						
		Different voltage 210V or 215V	Different voltage 400V	Heat resistance of 60 °C	Heat resistance of 80 °C	Acid-resistant (salt-resistant) coating	Specified color	MFP treatment
25	Exhaust	x	x	x	x	○	○	x
	Intake	x	x	x	x	○	○	x
30	Exhaust	x	x	x	x	○	○	x
	Intake	x	x	x	x	○	○	x
35	Exhaust	x	*1	○	x	○	○	○
	Intake	x	*1	○	x	○	○	○
40	Exhaust	○	*1	○	x	○	○	○
	Intake	○	*1	○	x	○	○	○
45	Exhaust	○	*1	○	x	○	○	○
	Intake	○	*1	○	x	○	○	○
50	Exhaust	○	*1	○	x	○	○	○
	Intake	○	*1	○	x	○	○	○
60	Exhaust	○	○	○	x	○	○	○
	Intake	○	○	○	x	○	○	○
75	Exhaust	○	○	○	x	○	○	○
	Intake	○	○	○	x	○	○	○
90	Exhaust	○	○	○	x	○	○	○
	Intake	○	○	○	x	○	○	○
105	Exhaust	○	○	○	x	○	○	○
	Intake	○	○	○	x	○	○	○
120	Exhaust	○	○	○	x	○	○	○
	Intake	○	○	○	x	○	○	○

*1: 400V class available for three-phase power supply models only

Selection chart

[Exhaust type]

Single-phase, impeller diameter from 25 to 50cm

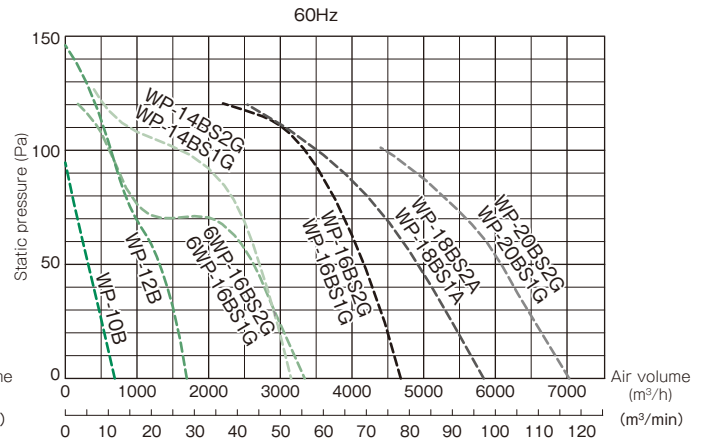
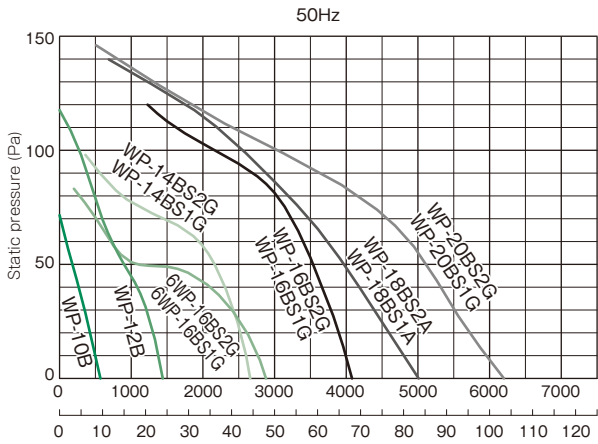

Three-phase, impeller diameter from 35 to 50cm

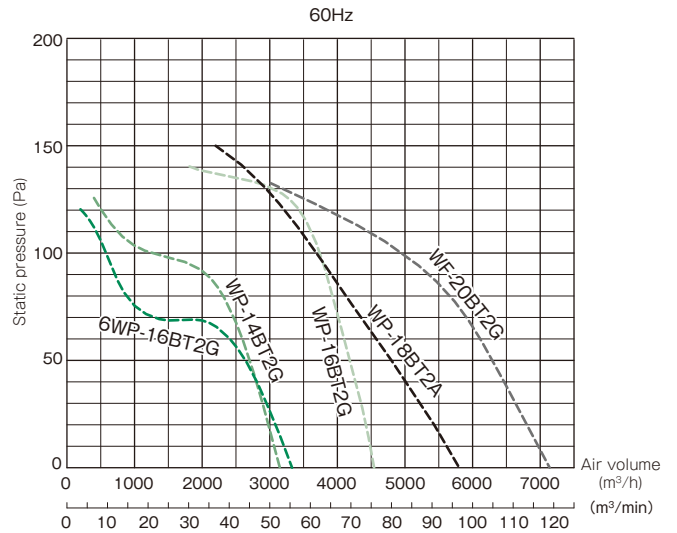
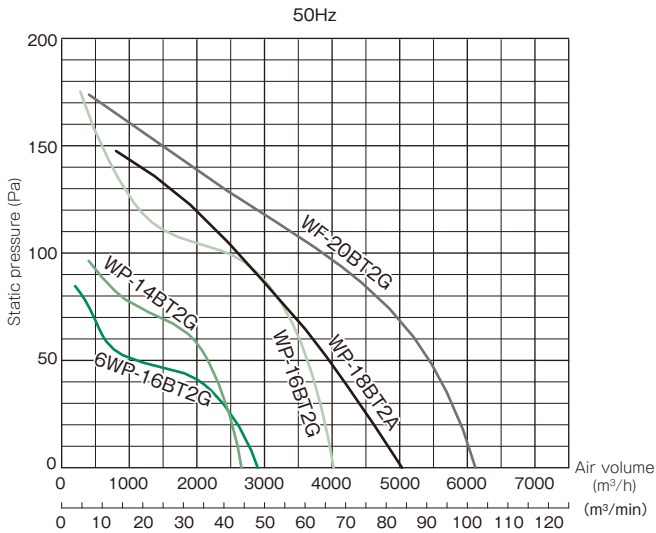

Three-phase, impeller diameter from 60 to 120cm

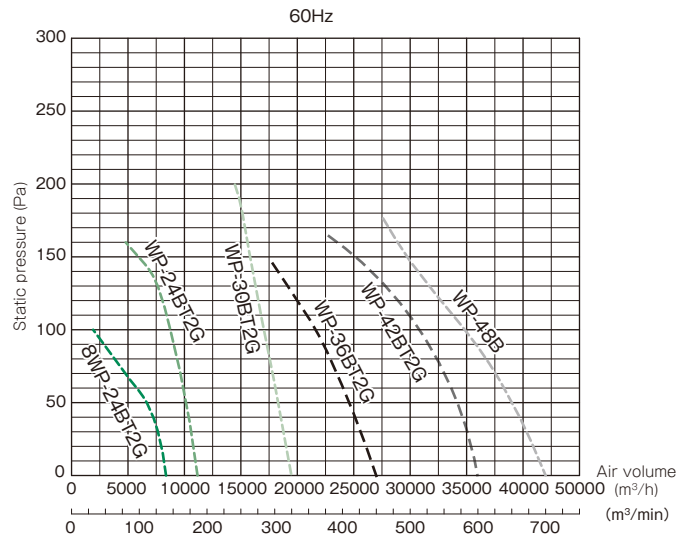
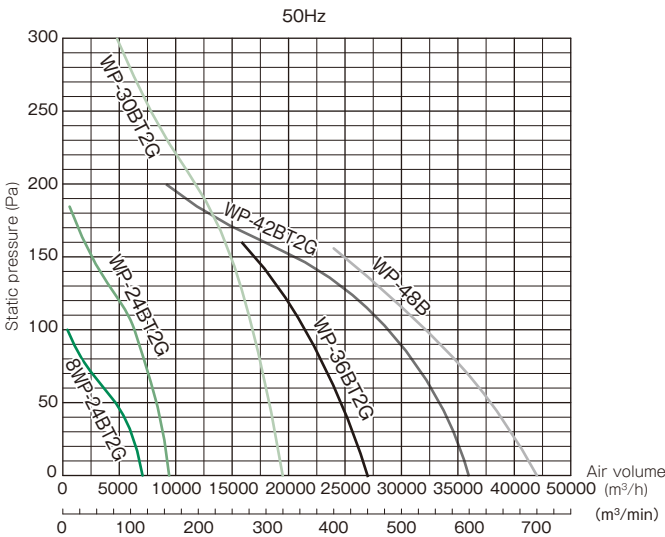

Selection chart

[Intake type]

Single-phase, impeller diameter from 25 to 50cm

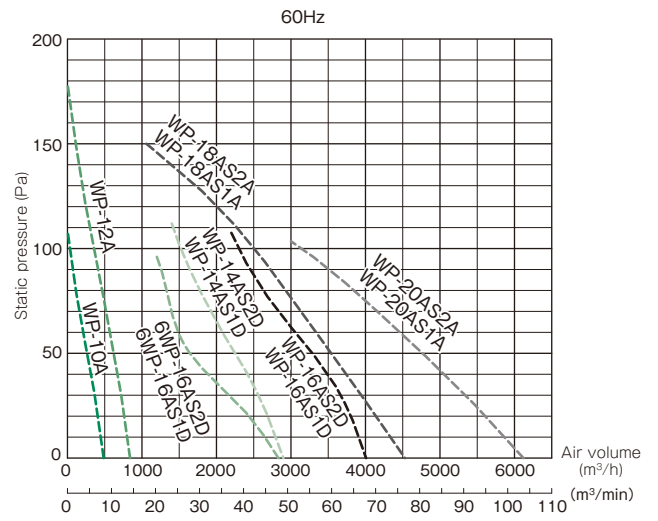
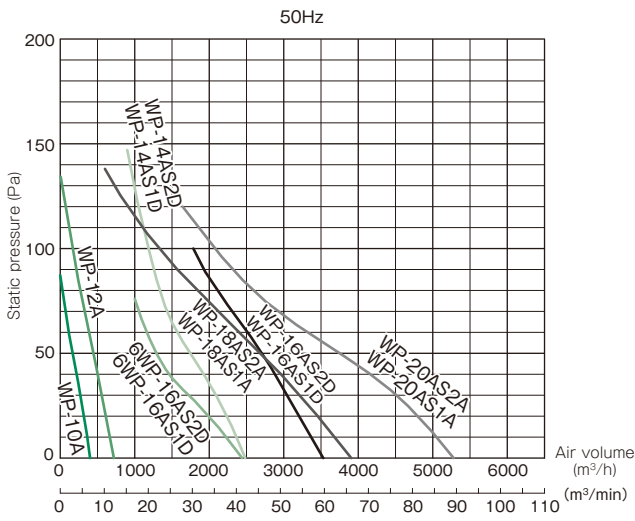

Three-phase, impeller diameter from 35 to 50cm

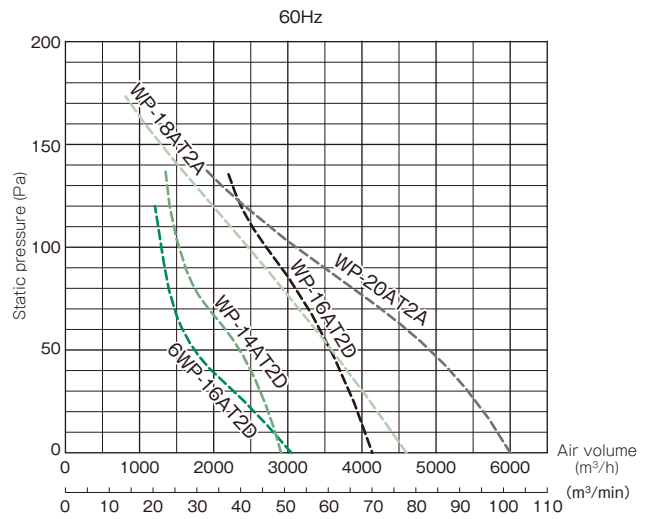
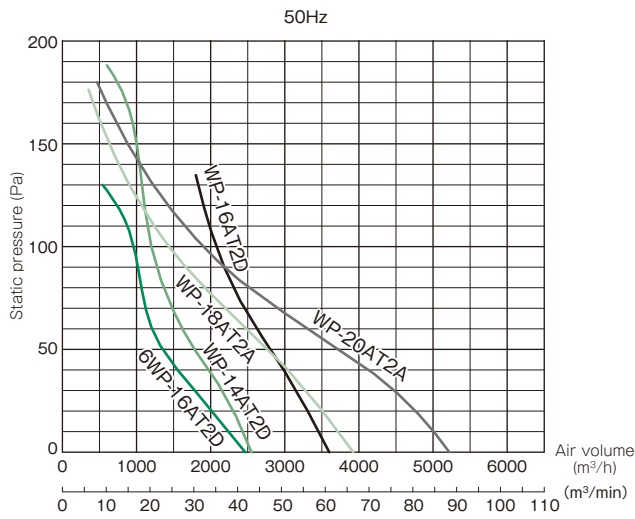

Three-phase, impeller diameter from 60 to 120cm

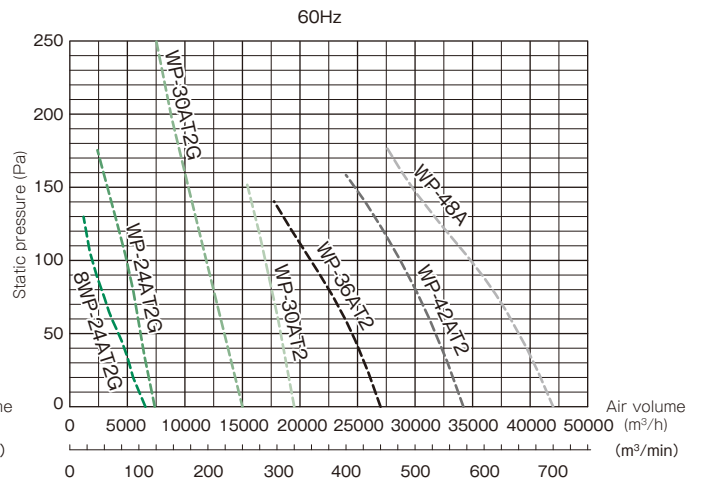
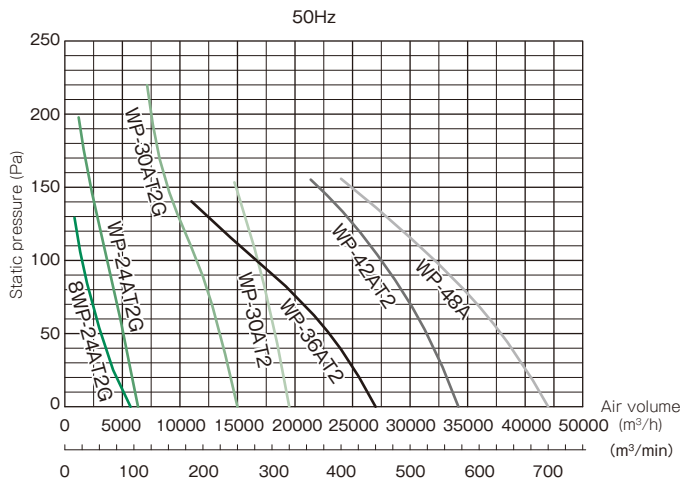

Assembly drawing [Exhaust Type]

* For intake type, please contact us.

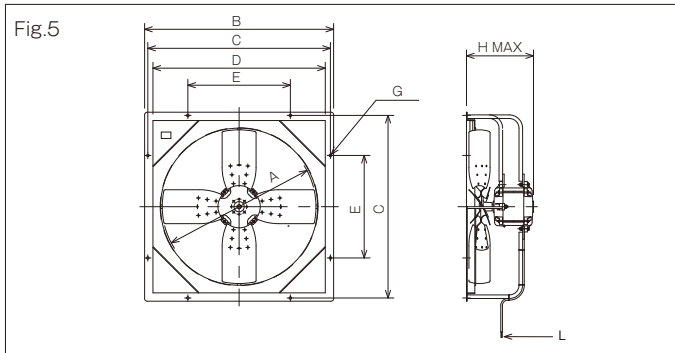
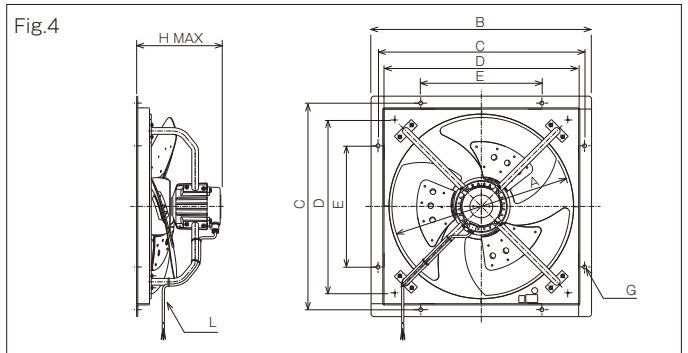
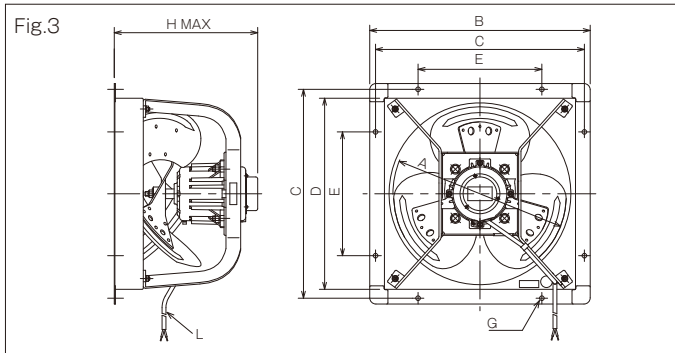
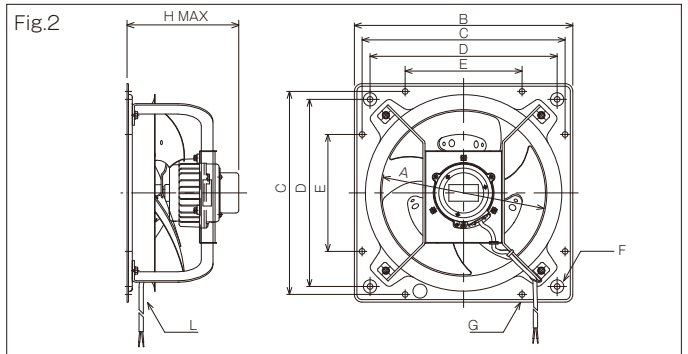
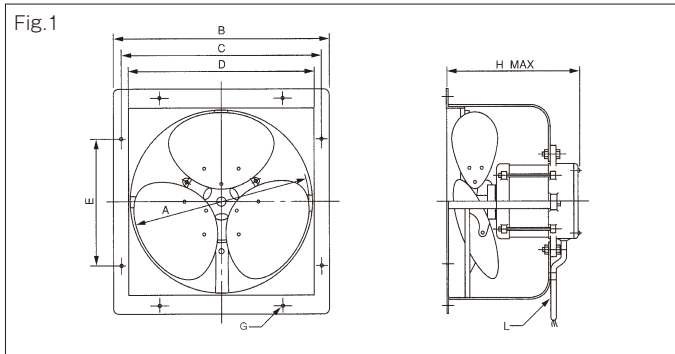

- Any model with the impeller diameter 35cm or more has a drain hole underneath the motor. (For installing the fan with the motor shaft positioned horizontally), make sure that the drain hole faces downward. When using it outdoors or under conditions of high humidity, remove the drain hole cap facing downward. When using it in any dusty place or when water comes into the fan, keep the cap attached and detach it occasionally to perform an inspection.
- It is standard to install the fan with the shaft positioned horizontally. If it is installed in a non-standard manner (e.g. at an attitude in which the shaft faces downward), make sure to specify it at the time of placing an order. Installation of any fan designed to be installed in the standard manner at an attitude in which it faces downward may cause failure.

* The shape varies slightly depending on the model.

Dimensions

(Unit:mm)

Fig.	Model	A	B	C	D	E	F	G	H	L
1	WP-10B	250	327	298	267	165	/	8×φ8.5	215	2PNCT×2 cores×0.75mm ² ×1m
	WP-12B	300	378	349	318	210	/	8×φ8.5	255	2PNCT×2 cores×0.75mm ² ×1m
2	WP-14BS1G	350	467	434	400	250	4×φ12	8×φ12	239	2PNCT×2 cores×0.75mm ² ×1m
	WP-14BS2G	350	467	434	400	250	4×φ12	8×φ12	239	2PNCT×2 cores×0.75mm ² ×1m
	WP-14BT2G	350	467	434	400	250	4×φ12	8×φ12	197	2PNCT×3 cores×0.75mm ² ×1m
	WP-16BS1G	400	518	485	450	280	4×φ12	8×φ12	244	2PNCT×2 cores×0.75mm ² ×1m
	WP-16BS2G	400	518	485	450	280	4×φ12	8×φ12	244	2PNCT×2 cores×0.75mm ² ×1m
	WP-16BT2G	400	518	485	450	280	4×φ12	8×φ12	202	2PNCT×3 cores×0.75mm ² ×1m
	6WP-16BS1G	400	518	485	450	280	4×φ12	8×φ12	244	2PNCT×2 cores×0.75mm ² ×1m
	6WP-16BS2G	400	518	485	450	280	4×φ12	8×φ12	244	2PNCT×2 cores×0.75mm ² ×1m
	6WP-16BT2G	400	518	485	450	280	4×φ12	8×φ12	202	2PNCT×3 cores×0.75mm ² ×1m
	3	WP-18BS1A	450	570	540	494	320	/	8×φ12	380
WP-18BS2A		450	570	540	494	320	/	8×φ12	380	2PNCT×2 cores×1.25mm ² ×1m
WP-18BT2A		450	570	540	494	320	/	8×φ12	350	2PNCT×3 cores×1.25mm ² ×1m
WP-20BS1G		500	659	620	563	355	/	8×φ15	395	2PNCT×2 cores×1.25mm ² ×1m
WP-20BS2G		500	659	620	563	355	/	8×φ15	395	2PNCT×2 cores×1.25mm ² ×1m
WP-20BT2G		500	659	620	563	355	/	8×φ15	365	2PNCT×3 cores×1.25mm ² ×1m
4	WP-24BT2G	600	760	720	664	400	/	8×φ15	380	2PNCT×3 cores×1.25mm ² ×1m
	8WP-24BT2G	600	760	720	664	400	/	8×φ15	380	2PNCT×3 cores×1.25mm ² ×1m
	WP-30BT2G	750	955	900	825	508	/	8×φ20	450	2PNCT×3 cores×2mm ² ×1m
	WP-36BT2G	900	1110	1040	980	610	/	8×φ20	440	2PNCT×3 cores×2mm ² ×1m
5	WP-42BT2G	1050	1262	1207	1132	656	/	8×φ20	560	2PNCT×3 cores×3.5mm ² ×1m
	WP-48B	1200	1475	1425	1345	800	/	8×φ20	540	2PNCT×3 cores×5.5mm ² ×3m

Applications

For factories, warehouses and workshops where explosive gas is generated

Feature

These fans are ideal for ventilation of any space where explosive gas or flammable gas is generated.

Standard Specifications

- Conforming to the JIS C 0905 and the test requirements formulated by the National Institute of Industrial Safety under the Ministry of Labour. Applicable under conditions with explosion class 2 or lower and ignitability of G4 or lower.
- Explosion class and ignitability

Explosion class \ Ignitability	G1 Exceeding 450 deg. C	G2 Exceeding 300 deg. C and not exceeding 450 deg. C	G3 Exceeding 200 deg. C and not exceeding 300 deg. C	G4 Exceeding 135 deg. C and not exceeding 200 deg. C
1	<ul style="list-style-type: none"> ● Acetone ● Ammonia ● Carbon monoxide ● Ethane ● Acetic acid ● Ethyl acetate 	<ul style="list-style-type: none"> ● Toluene ● Propane ● Benzene ● Methanol ● Methane 	<ul style="list-style-type: none"> ● Ethanol ● Isopentyl acetate ● 1-Butanol ● Butane ● Acetic anhydride 	<ul style="list-style-type: none"> ● Gasoline ● Hexane
2	<ul style="list-style-type: none"> ● Coal gas 	<ul style="list-style-type: none"> ● Ethylene 		<ul style="list-style-type: none"> ● Acetaldehyde ● Ethyl ether

<Reference>

Explosion class: Defined in the JIS standards and classified according to the minimum size of the clearance that causes flame propagation in the explosion test with the standard container into three classes, among which Class 3 is the most dangerous, followed by Class 2 and then by Class 1. Ignitability: Defined in the JIS standard and classified according to the ignition point into five groups, among which Group 5 (G5) is the highest and G1 is the lowest.

- Equipped with a terminal box with a pressure stud retraction system

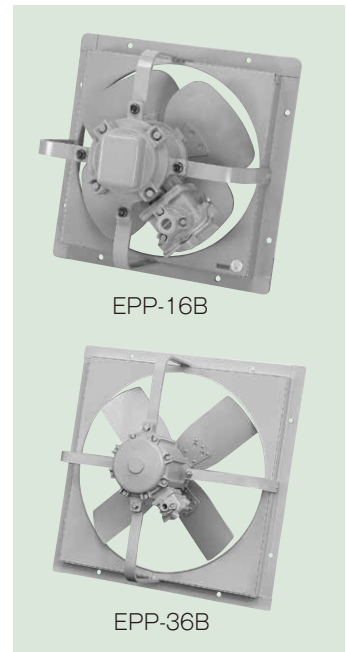
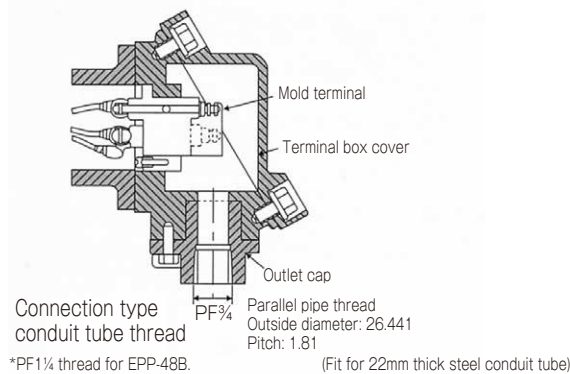

* Please note that the photo shows typical examples and that they may partly differ from actual items.

Specification table

Airflow direction	Model	Impeller diameter (cm)	Number of poles (P)	Power supply (V)	Nominal output (W)	Air volume (m ³ /h)		Power consumption (W)		Allowable current (A)		Starting current (A)		Noise (dB(A))		Approx. mass (kg)
						50Hz	60Hz	50Hz	60Hz	50Hz	60Hz	50Hz	60Hz	50Hz	60Hz	
Exhaust type	EPP-8B	20	4	Single-phase100	20	408	492	28	31	0.7	0.7	0.9	0.81	38	42	14.5
	EPP-10B	25				570	690	30	35	0.35	0.35	0.45	0.41	45	49	15
	EPP-12B	30		Single-phase100	50	1020	1200	45	50	1.1	1.1	2.6	2.6	51	55	21
				Single-phase200						0.55		1.3	1.1			
				Three-phase200						75	55	60	0.6			
	EPP-14B	35		Single-phase100	100	2820	2760	130	130	2.4	2	7.2	6.8	54	61	27
				Single-phase200						1.2	1	3.6	3.4			
				Three-phase200						135	135	0.74	0.61			
	EPP-16B	40		Single-phase100	200	4140	4140	240	260	3.2	3	7.6	7.4	60	63	37
				Single-phase200						1.1	1.5	3.8	3.7			
				Three-phase200						1.22	1.04	4.7	4.3			
	6EPP-16B	40		Single-phase100	100	2880	2880	100	100	1.9	1.8	2.3	2.2	48	54	
				Single-phase200						0.95	0.9	1.2	1.2			
				Three-phase200						0.72	0.64	2	1.8			
	EPP-18B	45		Single-phase100	250	4380	4380	220	220	5.4	5	15	14	55	56	45
				Single-phase200						2.2	2	7.5	7			
Three-phase200			190	190						1.4	1.3	5	4.5			
EPP-20B	50	Single-phase100	400	6240	6240	340	340	7	6	18	16	58	60	57		
		Single-phase200						3.5	3	9	8					
		Three-phase200						300	300	2.15	2				7.5	6.8
EPP-24B	60	6	Three-phase200	750	11400	11400	770	750	3.7	3.4	15	13	66	67	13	
8EPP-24B	60	8		400	8700	8700	360	400	2.7	2.7	5	4.5	59	59		
EPP-30B	75	6		1500	19500	19500	1600	1600	7.5	6.8	25	21	72	73	95	
EPP-36B	90	6		2200	27600	27600	2000	2400	9.5	8.8	40	35	77	80	140	
					34800	34800	2200	2000	11	10	48	42	74	77	165	
EPP-42B	105	8		3700	42000	42000	3200	3200	22	20	86	74	75	76	220	
EPP-48B	120	10														

- The power consumption, air volume and noise figures mentioned above represent the values in the state of operation under free air conditions.
- The air volume has been measured using the JIS C 9603-compliant orifice chamber method, except for models where an impeller diameter ranges from 90cm to 120cm, for which the JIS B 8330-compliant suction pipe method was employed.
- The noise figure represents the average of the values measured at three points that are 1.5 meters distant from one another. The value in actual operation varies depending on the installation method, the duct form, and so on.
- The allowable current figure represents the critical point of operation. Use it for reference at the time of selecting a motor breaker.
- Make sure that the product is used in a place where no corrosive or explosive gas or no steam is generated.
- The fan should be installed in an environment where the temperature ranges from -10 °C to +40 °C, the humidity is 85% or less, and the elevation is 1,000m or less. Observe these conditions when using the product.

■ Specification table

Airflow direction	Model	Impeller diameter (cm)	Number of poles (P)	Power supply (V)	Nominal output (W)	Air volume (m³/h)		Power consumption (W)		Allowable current (A)		Starting current (A)		Noise (dB(A))		Approx. mass (kg)
						50Hz	60Hz	50Hz	60Hz	50Hz	60Hz	50Hz	60Hz	50Hz	60Hz	
Intake type	EPP-10A	25	2	Single-phase100	20	402	486	35	45	0.7	0.7	0.9	0.81	45	49	15
	Single-phase200	0.35		0.35						0.45	0.41					
	EPP-12A	30	4	Three-phase200	75	720	840	60	65	0.6	0.52	2	1.8	51	55	21
	EPP-14A	35		Single-phase100						100	2100	2040	130	130	2.4	2
	Single-phase200	1.2	1	36	3.4											
	EPP-16A	40	6	Three-phase200	200	3300	3300	240	260	3.2	3	7.6	7.4	60	63	37
				Single-phase100						1.7	1.5	3.8	3.7			
				Single-phase200						1.22	1.04	4.7	4.3			
	6EPP-16A	40	6	Three-phase200	100	2040	2040	100	100	1.9	1.8	2.3	2.2	48	54	37
				Single-phase100						0.95	0.9	1.2	1.2			
Single-phase200				0.72						0.64	2	1.8				
EPP-18A	45	6	Three-phase200	250	3484	3484	190	190	1.4	1.3	5	4.5	55	56	45	
EPP-20A	50								400	4980	4980	300	300	2.15	2	7.5

- The power consumption, air volume and noise figures mentioned above represent the values in the state of operation under free air conditions.
- The air volume has been measured using the JIS C 9603-compliant orifice chamber method.
- The noise figure represents the average of the values measured at three points that are 1.5 meters distant from one another. The value in actual operation varies depending on the installation method, the duct form, and so on.
- The allowable current figure represents the critical point of operation. Use it for reference at the time of selecting a motor breaker.
- Make sure that the product is used in a place where no corrosive or explosive gas or no steam is generated.
- The fan should be installed in an environment where the temperature ranges from -10 °C to +40 °C, the humidity is 85% or less, and the elevation is 1,000m or less. Observe these conditions when using the product.

■ Special Specifications

Impeller diameter (cm)	Airflow direction	Special order features						
		Different voltage 210V or 215V	Different voltage 400V	Heat resistance of 60 °C	Heat resistance of 80 °C	Acid-resistant (salt-resistant) coating	Specified color	MFP treatment
20	Exhaust	x	x	x	x	○	○	x
	Intake	x	x	x	x	○	○	x
25	Exhaust	x	x	x	x	○	○	x
	Intake	x	x	x	x	○	○	x
30	Exhaust	x	*1	x	x	○	○	x
	Intake	x	*1	x	x	○	○	x
35	Exhaust	x	*1	x	x	○	○	x
	Intake	x	*1	x	x	○	○	x
40	Exhaust	x	*1	x	x	○	○	x
	Intake	x	*1	x	x	○	○	x
45	Exhaust	x	*1	x	x	○	○	x
	Intake	x	*1	x	x	○	○	x
50	Exhaust	x	*1	x	x	○	○	x
	Intake	x	*1	x	x	○	○	x
60	Exhaust	x	○	x	x	○	○	x
	Intake	x	○	x	x	○	○	x
75	Exhaust	x	○	x	x	○	○	x
	Intake	x	○	x	x	○	○	x
90	Exhaust	x	○	x	x	○	○	x
	Intake	x	○	x	x	○	○	x
105	Exhaust	x	○	x	x	○	○	x
	Intake	x	○	x	x	○	○	x
120	Exhaust	x	○	x	x	○	○	x
	Intake	x	○	x	x	○	○	x

*1: 400V class available for three-phase power supply models only

■ Selection chart

[Exhaust type]

Single-phase, impeller diameter from 20 to 40cm, four poles

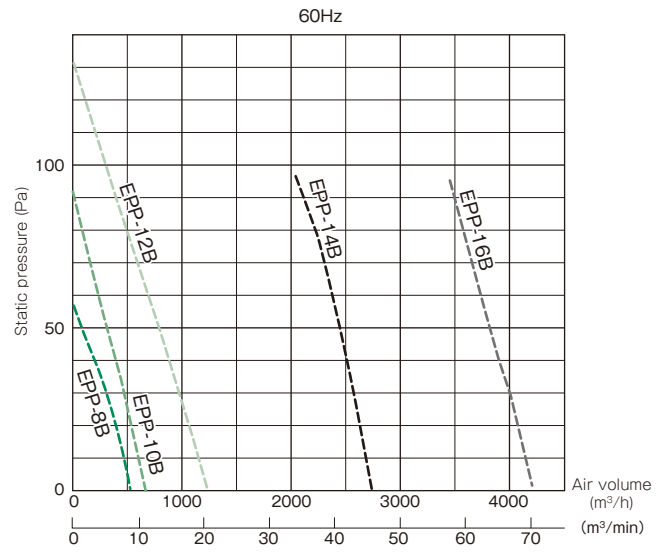
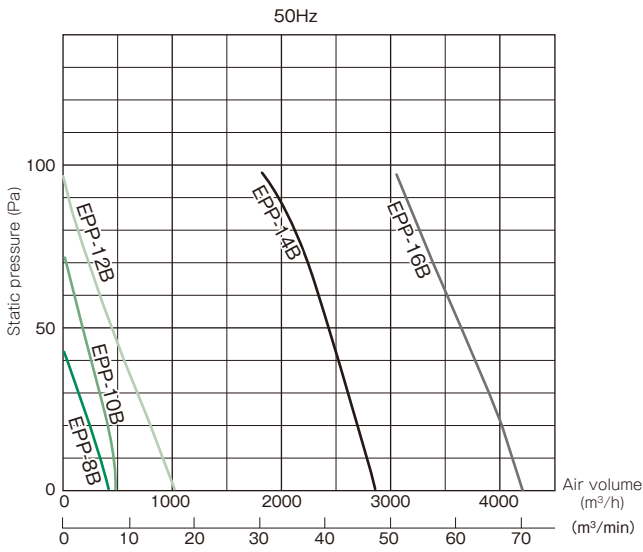

Single-phase, impeller diameter from 40 to 50cm, six poles

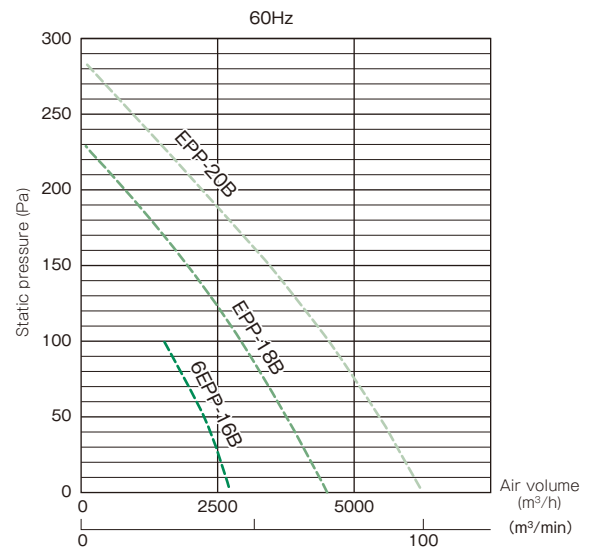
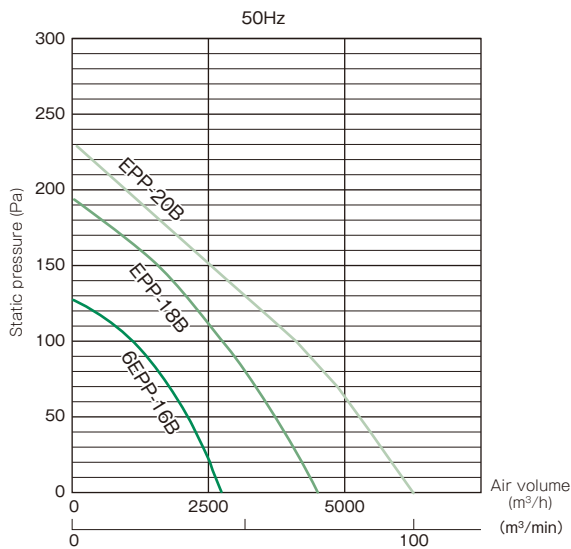

Three-phase, impeller diameter from 30 to 40cm, four poles

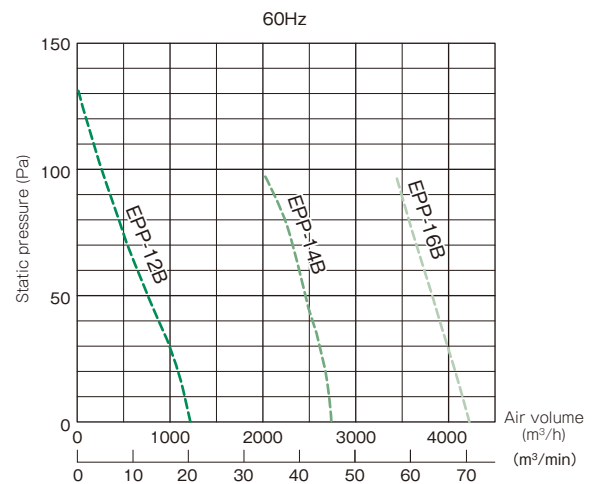
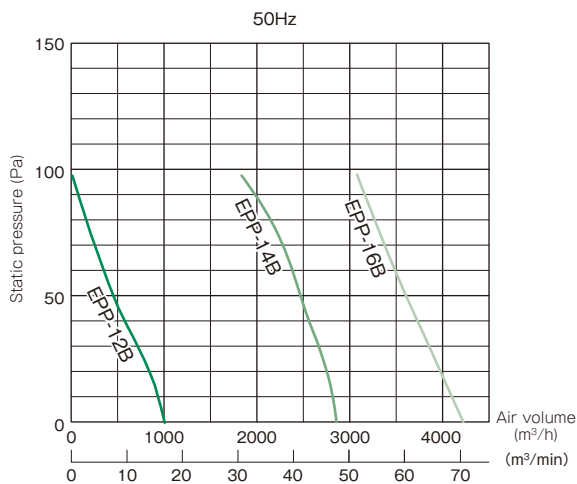

Selection chart

[Exhaust type]

Three-phase, impeller diameter 40cm, six poles / eight poles; from 45 to 120cm

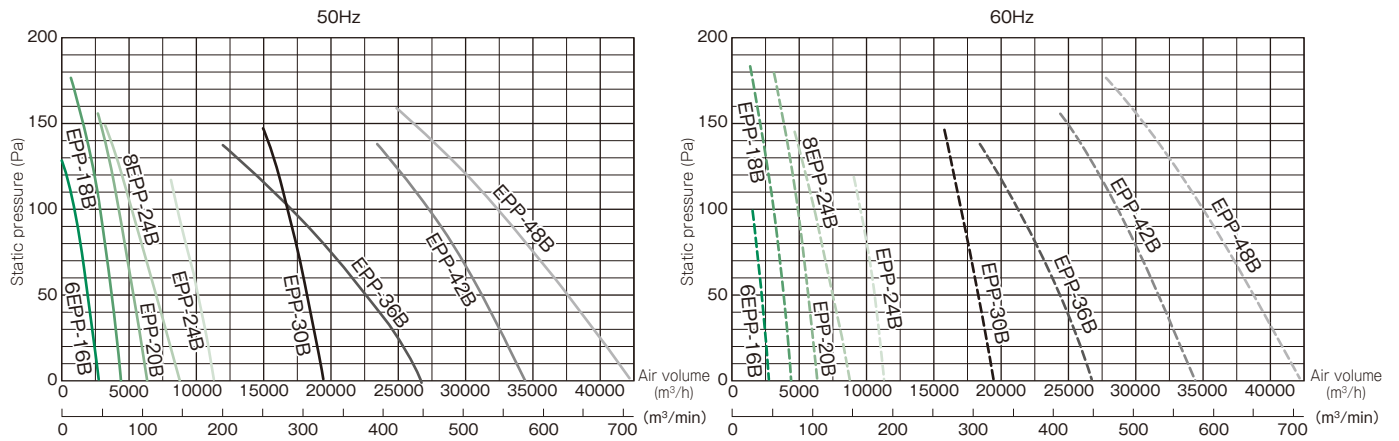

[Intake type]

Single-phase, impeller diameter from 25 to 40cm, four poles

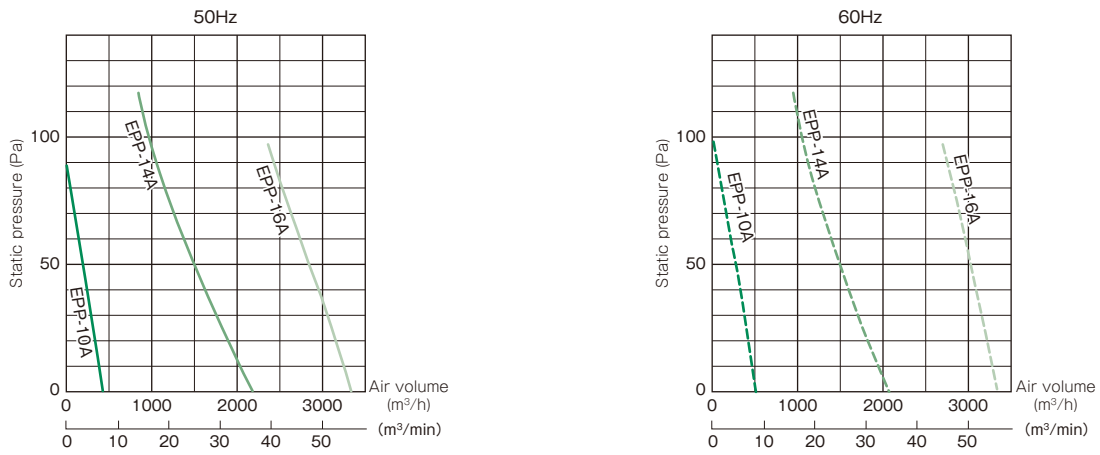

Single-phase, impeller diameter 40cm, six poles

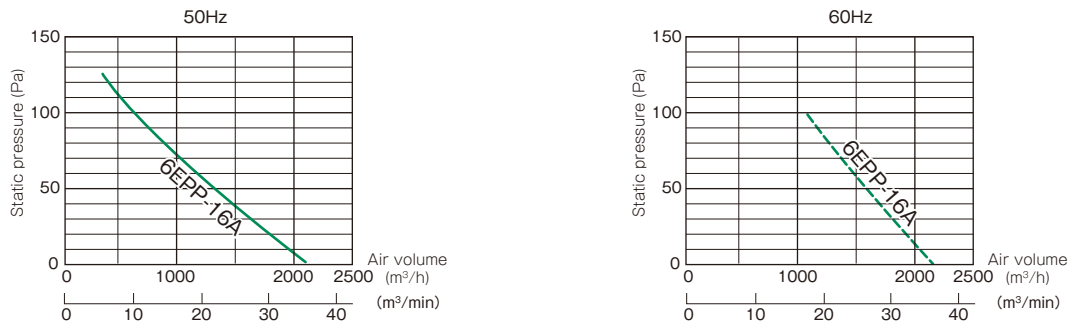

Three-phase, impeller diameter from 30 to 40cm, four poles

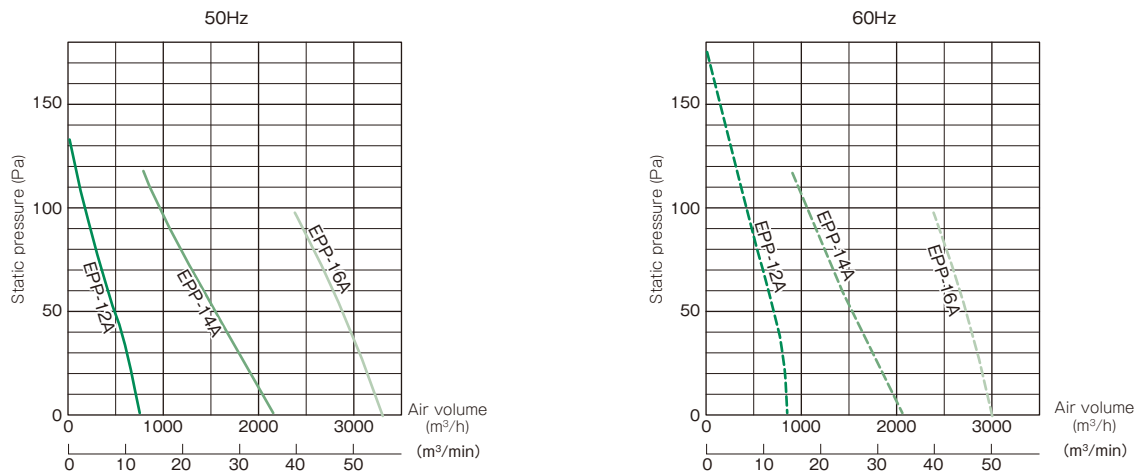

Selection chart

[Intake type]

Three-phase, impeller diameter from 40 to 50cm, six poles

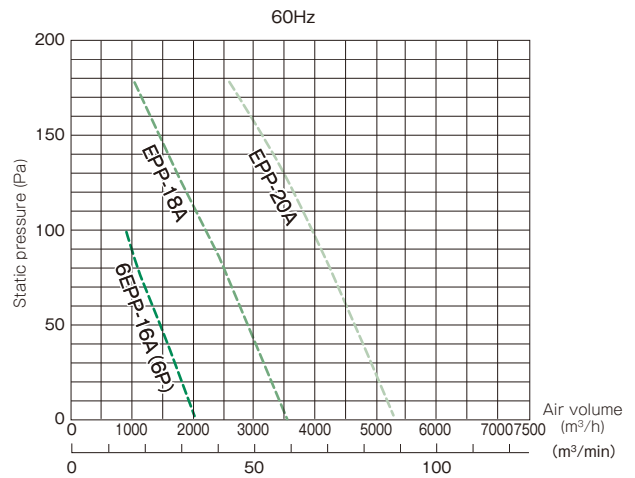
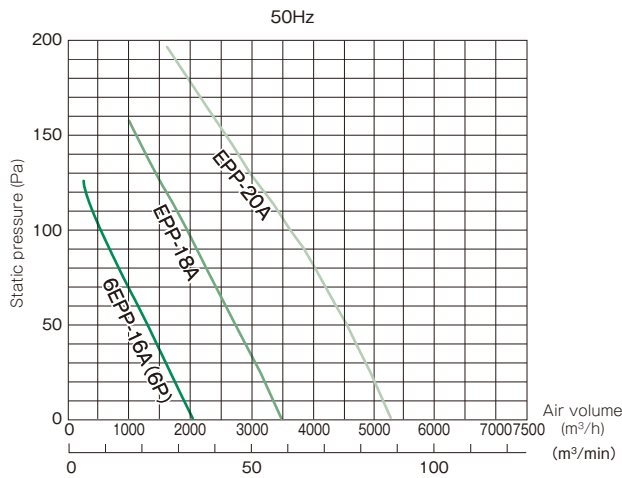

Assembly drawing [Exhaust Type]

* For intake type, please contact us.

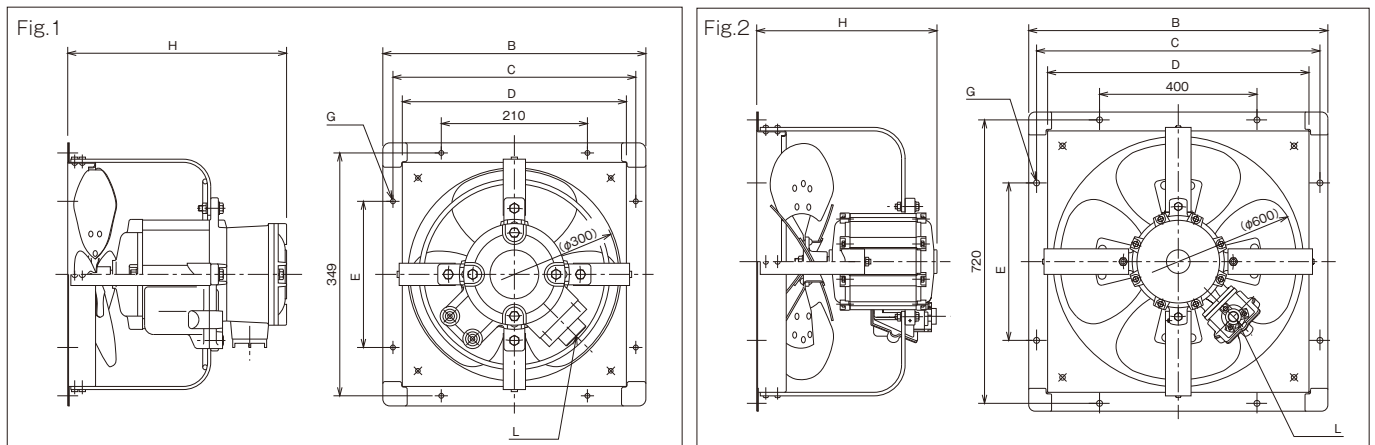

Dimensions

(Unit:mm)

Fig.	Model	A	B	C	D	E	G	H	L
1	EPP-8B	200	276	246	220	162	8×φ7	310	PF¾ thread
	EPP-10B	250	327	298	267	165	8×φ8.5	315	PF¾ thread
	EPP-12B	300	378	349	322	210	8×φ7	325	PF¾ thread
2	EPP-14B	350	467	434	391	250	8×φ12	355	PF¾ thread
	EPP-16B	400	518	485	442	280	8×φ12	365	PF¾ thread
	6EPP-16B	400	518	485	442	280	8×φ12	365	PF¾ thread
	EPP-18B	450	570	540	494	320	8×φ12	425	PF¾ thread
	EPP-20B	500	659	620	563	355	8×φ15	445	PF¾ thread
	EPP-24B	600	760	720	664	400	8×φ15	490	PF¾ thread
	8EPP-24B	600	760	720	664	400	8×φ15	490	PF¾ thread
	EPP-30B	750	955	900	825	508	8×φ20	510	PF¾ thread
	EPP-36B	900	1110	1040	980	610	8×φ20	475	PF¾ thread
	EPP-42B	1050	1262	1207	1132	656	8×φ20	495	PF¾ thread
	EPP-48B	1200	1475	1425	1345	800	8×φ20	600	PF1¼ thread

Applications

For kitchens, coastal areas, food factories, and other places where rust prevention is required

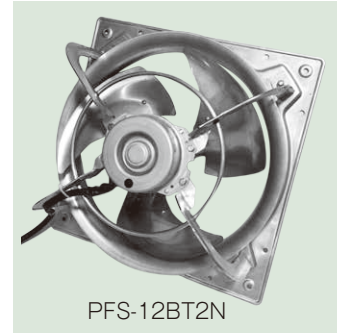

PFS-12BT2N

* Please note that the photo shows typical examples and that they may partly differ from actual items.

Specification table

Airflow direction	Model	Impeller diameter (cm)	Number of poles (P)	Power supply (V)	Nominal output (W)	Air volume (m ³ /h)		Power consumption (W)		Allowable current (A)		Starting current (A)		Noise (dB(A))		Approx. mass (kg)
						50Hz	60Hz	50Hz	60Hz	50Hz	60Hz	50Hz	60Hz	50Hz	60Hz	
Exhaust type	PFS-10BSD	25	4	Single-phase100	20	1020	1200	43	48	0.7	0.8	1.2	1.1	41	44	3.5
	PFS-12BS1N							61	90	0.9	1.2	1.9	1.7	39.1	42.8	
	PFS-12BS2N	30		Single-phase200	50	1873	2140	61	90	0.5	0.6	0.8	0.7			
	PFS-12BT2N			Three-phase200				70	98	0.4	0.6	1.0	0.9			
	PFS-16BS1D	40		Single-phase100	200	3678	4272	165	210	3.5	3.45	8.3	7.9	51	55	10.7
	PFS-16BS2D			Single-phase200				180	210/230	1.8	1.8	4.3	4.2/4.6			
	PFS-16BT2D	40		Three-phase200	200	3762	4392	150	200	1.2	1.2	4.1	3.9			
PFS-20BT2A	50		6					400	6360	7440	260	380	2.5	3.2	6.5	5.7
Intake type	PFS-12AS1N	30	4	Single-phase100	50	1654	1873	67	96	1.1	1.4	1.9	1.7	45.6	49.7	5.4
	PFS-12AS2N			Single-phase200				67	96	0.6	0.6	0.8	0.7			
	PFS-12AT2N			Three-phase200				1678	1902	71	102	0.5	0.5			

- The power consumption, air volume and noise figures mentioned above represent the values in the state of operation under free air conditions.
- The air volume has been measured using the JIS C 9603-compliant orifice chamber method.
- The noise figure represents the average of the values measured at three points that are 1.5 meters distant from one another. The value in actual operation varies depending on the installation method, the duct form, and so on.
- The allowable current figure represents the critical point of operation. Use it for reference at the time of selecting a motor breaker.
- When using the product, observe the following conditions: Temperature from -30 °C to +50 °C for three-phase power supply models, from -10 °C to +50 °C for single-phase power supply models, humidity 95% or less, elevation 1,000m or less, in a place where no corrosive or explosive gas or no steam is generated. (from -30 °C to +50 °C for PFS-12B(A)S1N and PFS-12B(A)S2N) (from -10 °C to +40 °C for PFS-20BT2A)

- A special silver acid-resistant coating has been applied to the motors.
- * Various stainless steel type models other than the above can be manufactured. For models, please contact us.

Special Specifications

Impeller diameter (cm)	Special order features						
	Different voltage 210V or 215V	Different voltage 400V	Heat resistance of 60 °C	Heat resistance of 80 °C	Acid-resistant (salt-resistant) coating	Specified color	MFP treatment
25	×	×	×	×	○	○	×
30	×	*1	×	×	○	○	×
40	○	*1	×	×	○	○	×
50	○	*1	×	×	○	○	×

*1: 400V class available for three-phase power supply models only

Selection chart

[Exhaust type]

Single-phase, impeller diameter from 25 to 40cm

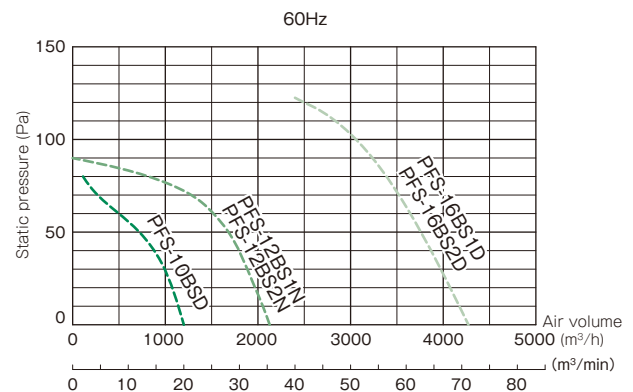
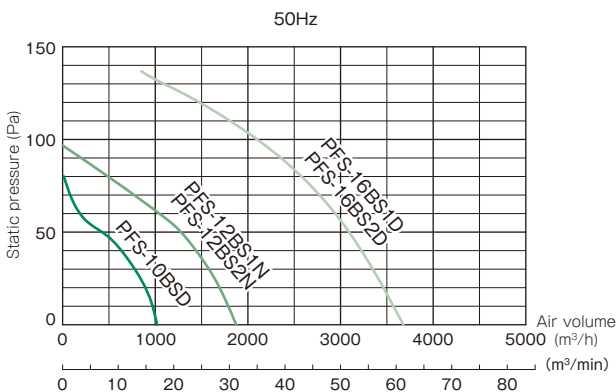

Three-phase, impeller diameter from 30 to 50cm

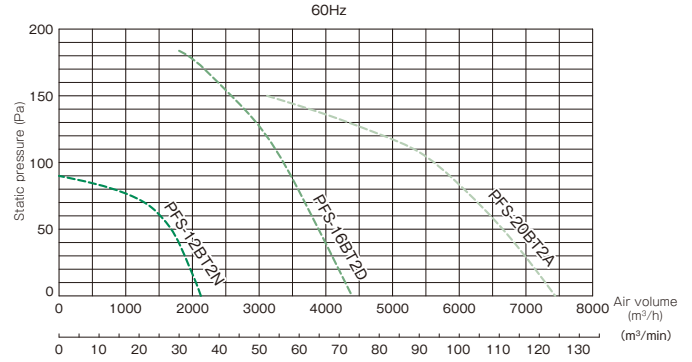
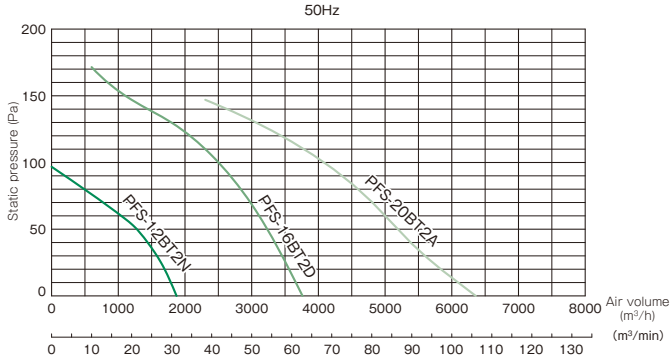

[Intake type]

impeller diameter from 30, four poles

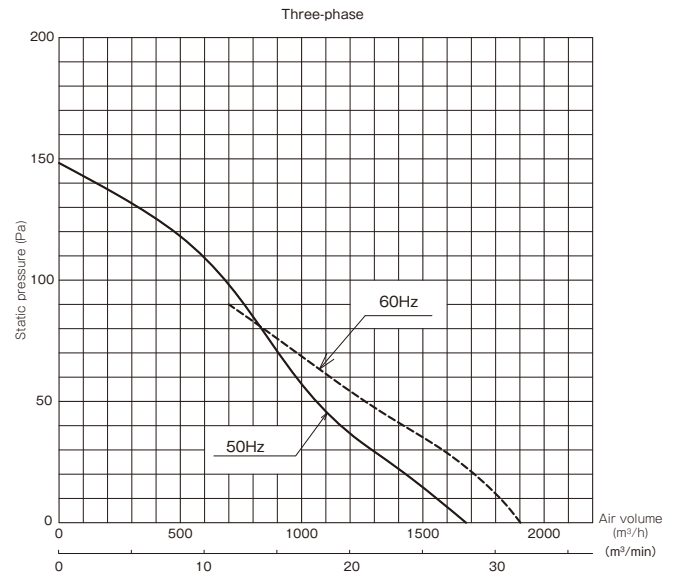
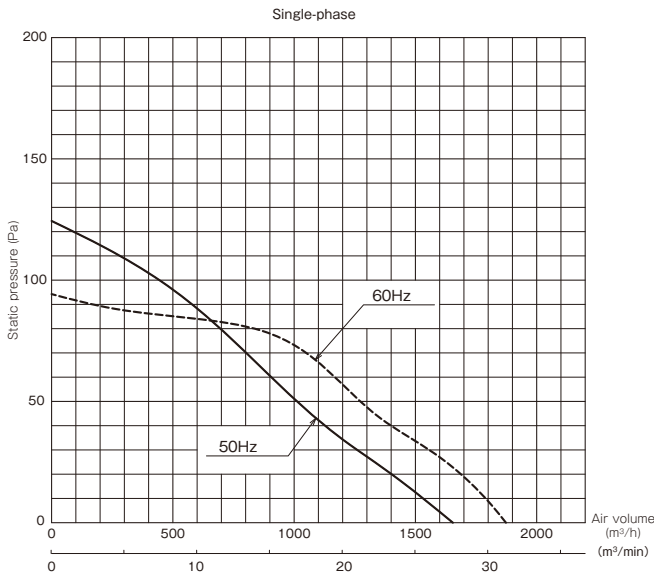

Assembly drawing

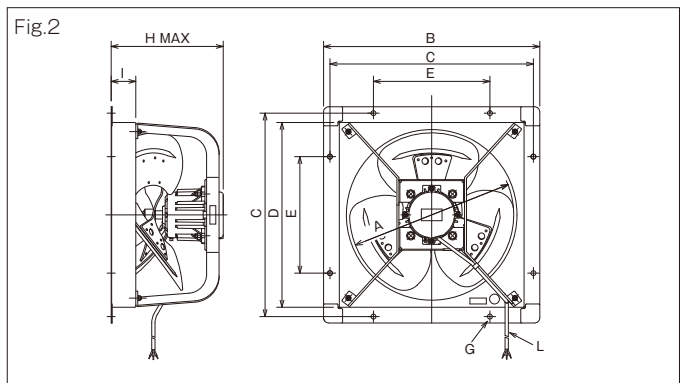
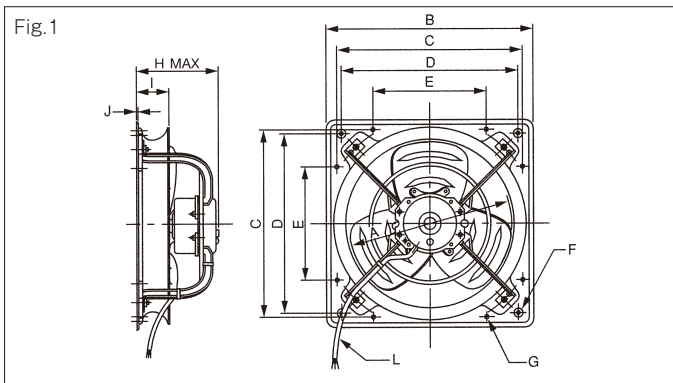

* The shape varies slightly depending on the model.

Dimensions

(Unit:mm)

Fig.	Model	A	B	C	D	E	F	G	H	I	J	L
1	PFS-10BSD	250	327	298	285	165	4×φ7	8×φ7	148.5	48	3	2PNCT×2 cores×0.75mm²×1m
	PFS-12BS1N	300	378	349	330	210	4×φ7	8×φ7	159	60	3	VCT×2 cores×0.75mm²×1m
	PFS-12BS2N	300	378	349	330	210	4×φ7	8×φ7	159	60	3	VCT×2 cores×0.75mm²×1m
	PFS-12BT2N	300	378	349	330	210	4×φ7	8×φ7	159	60	3	VCT×3 cores×0.75mm²×1m
	PFS-16BS1D	400	518	485	450	280	4×φ12	8×φ12	198	/	3	VCT×2 cores×0.75mm²×1m
	PFS-16BS2D	400	518	485	450	280	4×φ12	8×φ12	198	/	3	VCT×2 cores×0.75mm²×1m
	PFS-16BT2D	400	518	485	450	280	4×φ12	8×φ12	198	/	3	VCT×3 cores×0.75mm²×1m
2	PFS-20BT2A	500	659	620	563	355	/	8×φ15	75	355	/	2PNCT×3 cores×1.25mm²×1m

Applications

For refrigerator-freezer warehouses, unit coolers, and other places where rust-preventive measures are required

Feature

These pressure fans are equipped with low-temperature-spec motors with stainless steel adopted for their outer shells, making them ideal for incorporating into unit coolers and freezers in food, pharmaceutical and other factories.

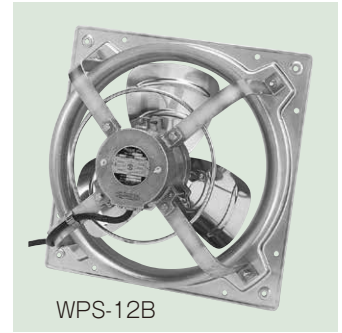

WPS-12B

* Please note that the photo shows typical examples and that they may partly differ from actual items.

Specification table

Airflow direction	Model	Impeller diameter (cm)	Number of poles (P)	Power supply (V)	Nominal output (W)	Air volume (m ³ /h)		Power consumption (W)		Allowable current (A)		Starting current (A)		Noise (dB(A))		Approx. mass (kg)
						50Hz	60Hz	50Hz	60Hz	50Hz	60Hz	50Hz	60Hz	50Hz	60Hz	
Exhaust type	WPS-12B	30	4	Three-phase200	50	1860	2200	44	60	0.4	0.4	0.6	0.6	45	49	6
	WPS-16BT2D	40			200	3800	4450	224	277	2.3	2.3	9.0	8.1	51	55	14
	WPS-16BT2				250/400	4450	5450	345	470	2.25	2.3	9.0	8.1	62	66	15.5

- The power consumption, air volume and noise figures mentioned above represent the values in the state of operation under free air conditions.
- The air volume has been measured using the JIS C 9603-compliant orifice chamber method.
- The noise figure represents the average of the values measured at three points that are 1.5 meters distant from one another. The value in actual operation varies depending on the installation method, the duct form, and so on.
- The allowable current figure represents the critical point of operation. Use it for reference at the time of selecting a motor breaker.
- Make sure that the product is used in a place where no corrosive or explosive gas or no steam is generated.
- Environment conditions (temperature and humidity) where the fan is installed are as follows. Observe these conditions when using the product.
- Temperature from -50 to +20 °C, humidity 95% or less, elevation 1,000m or less

With T-drain, 3-phase 200V

Airflow direction	Model	Impeller diameter (cm)	Number of poles (P)	Power supply (V)	Air volume (m ³ /h)		Power consumption (W)		Allowable current (A)		Starting current (A)		Noise (dB(A))		Approx. mass (kg)
					50Hz	60Hz	50Hz	60Hz	50Hz	60Hz	50Hz	60Hz	50Hz	60Hz	
Exhaust type	WPS-12B-T	30	4	3-phase 200	1860	2200	44	60	0.4	0.4	0.6	0.6	45	49	6
	WPS-16BT2D-T	40		3-phase 200/220	3800	4450	224	227/287	2.3	2.3/2.4	9.0	8.1/8.9	51	55	14

- Temperature : WPS-12B-T is -50°C~+20°C, WPS-16BT2D-T is -50°C~+30°C.
- For inquiries, please inform us of the shaft type (Shaft bottom or shaft horizontal). The T-drain must be positioned at the bottom and the product specifications are different.
- It is not suitable for cleaning by immersion in water, strong jet (high pressure cleaning, etc.), or chemicals.
- Fore safety and waterproof performance, do not clean the product while it is running.
- Please contact us for special specifications.

Selection chart

[Exhaust type]

Three-phase, impeller diameter from 30 to 40cm

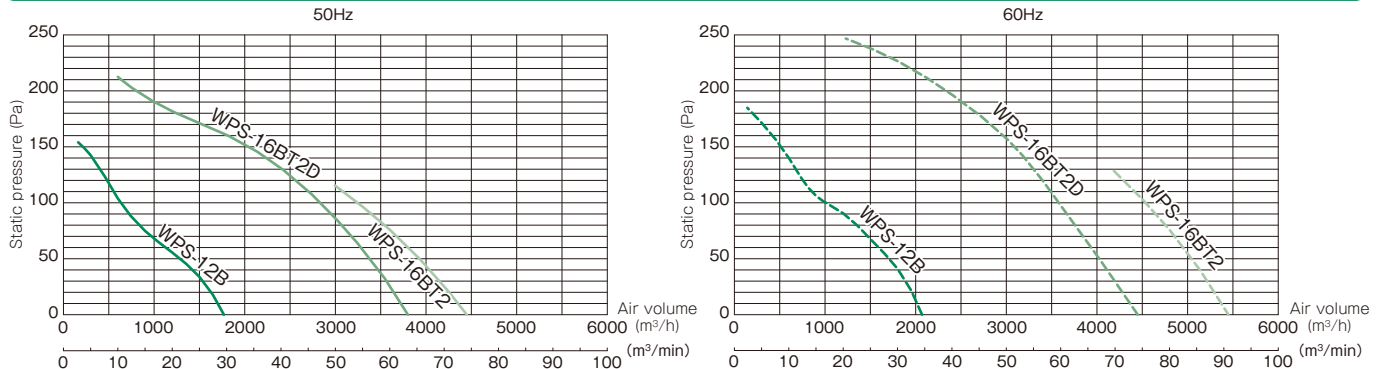

With T-drain

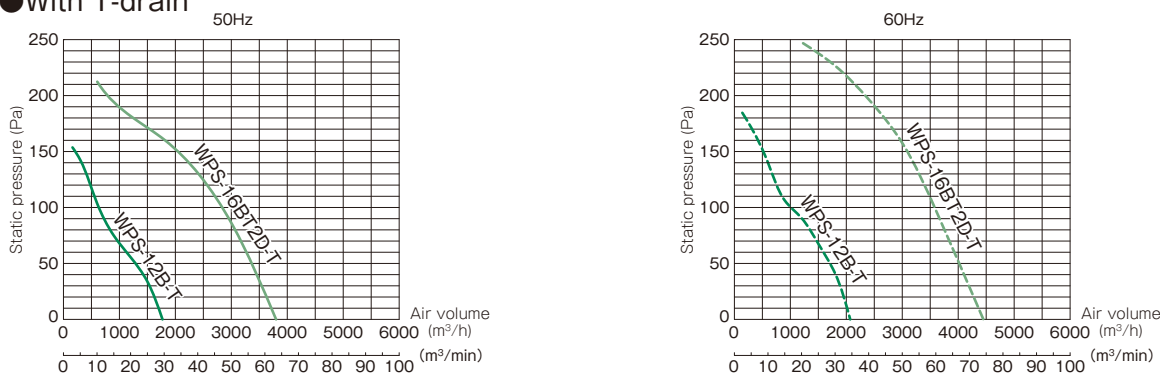

■ Assembly drawing

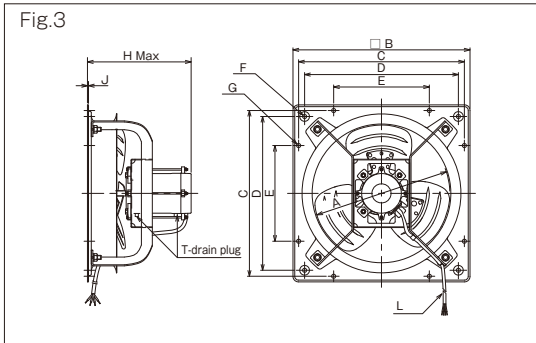
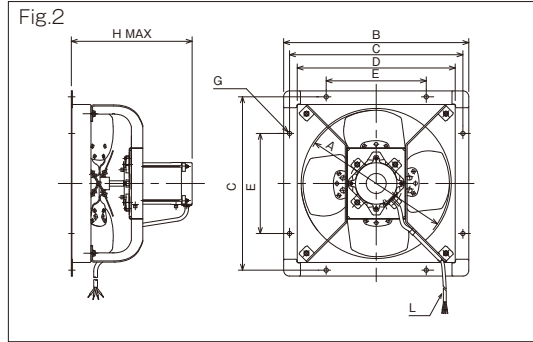
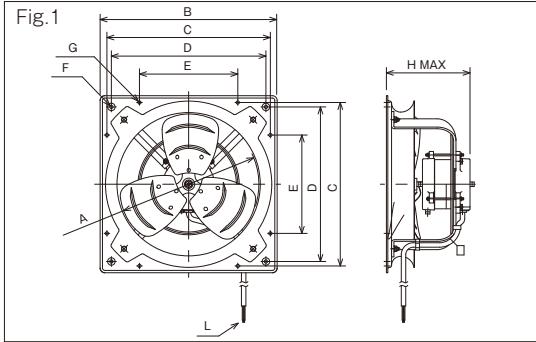

* The shape varies slightly depending on the model.

■ Dimensions

(Unit:mm)

Fig.	Model	A	B	C	D	E	F	G	H	J	L
1	WPS-12B	300	378	349	330	210	4×φ7	8×φ7	179	—	2PNCT×4 cores×0.75mm ² ×1m
	WPS-16BT2D	400	518	485	450	280	4×φ12	8×φ12	303	—	SRCT×4 cores×1.25mm ² ×1m
2	WPS-12BT2	410	518	485	442	280	—	8×φ12	338	—	SRCT×4 cores×1.25mm ² ×1m
3	WPS-12B-T	300	378	349	330	210	4×φ7	8×φ7	179	3	SRCT×4 cores×0.75mm ² ×1m
	WPS-16BT2D-T	400	518	485	450	280	4×φ12	8×φ12	303	3	SRCT×4 cores×1.25mm ² ×1m

Applications

For incorporating into oil coolers, unit coolers, and other equipment

Feature

These pressure fans have been developed on the assumption of incorporating into equipment without using mounting frames. They are ideal for mounting to oil coolers and unit coolers, in particular, and other equipment with small mounting space.

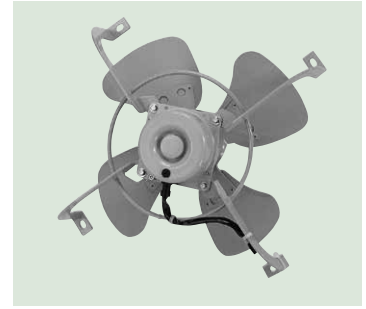

* Please note that the photo shows typical examples and that they may partly differ from actual items.

Specification table

Airflow direction	Model	Impeller diameter (cm)	Number of poles (P)	Power supply (V)	Nominal output (W)	Air volume (m³/h)		Power consumption (W)		Allowable current (A)		Starting current (A)		Noise (dB(A))		Approx. mass (kg)
						50Hz	60Hz	50Hz	60Hz	50Hz	60Hz	50Hz	60Hz	50Hz	60Hz	
Exhaust type	TP-12BT2K	30	4	Three-phase 200	50	1380	1680	66	80/86	0.42	0.42/0.43	1.0	0.96/1.05	41	44	3.2
	TP-13B-1	33				2040	2340	88	100	0.56	0.51	1.1	1	53	56	3.5
	TP-14BT2N	35			100	2831	3231	138	173	1.1	1.0	2.9	2.7	43.2	46	7.2
	TP-16BT2	40			200	3600	4230	240	290	1.38	1.38	5.4	5.2	54	58	7.4
	6TP-16BT2		6		100	2700	3120	125	160	0.75	0.85	2.2	2.1	46	50	6.5
	4TP-18B1	45	4		400	5880	6720	340	520	2	2.3	9.7	9.3	61	65	10
	TP-18B		6		200	3840	4320	150	210	0.85	0.90	2.5	2.4	50	54	7.9

- The power consumption, air volume and noise figures mentioned above represent the values in the state of operation under free air conditions.
- The air volume has been measured in the JIS C 9603-compliant orifice chamber method.
- The noise figure represents the average of the values measured at three points that are 1.5 meters distant from one another. The value in actual operation varies depending on the installation method, the duct form, and so on.
- The allowable current figure represents the critical point of operation. Use it for reference at the time of selecting a motor breaker.
- Elevation 1,000m or less. Make sure that the product is used in a place where no corrosive or explosive gas or no steam is generated.
- TP-16BT2, 6TP-16BT2, TP-18B: Temperature from -50 to +40 °C, humidity 45 to 85%
- TP-12BT2K, TP-13B-1: Temperature from -50 to +40 °C, humidity 45 to 95% or less
- TP-14BT2N: Temperature from -30 to +50 °C, humidity 90% or less

Selection chart

[Exhaust type]

Three-phase, impeller diameter from 30 to 45cm

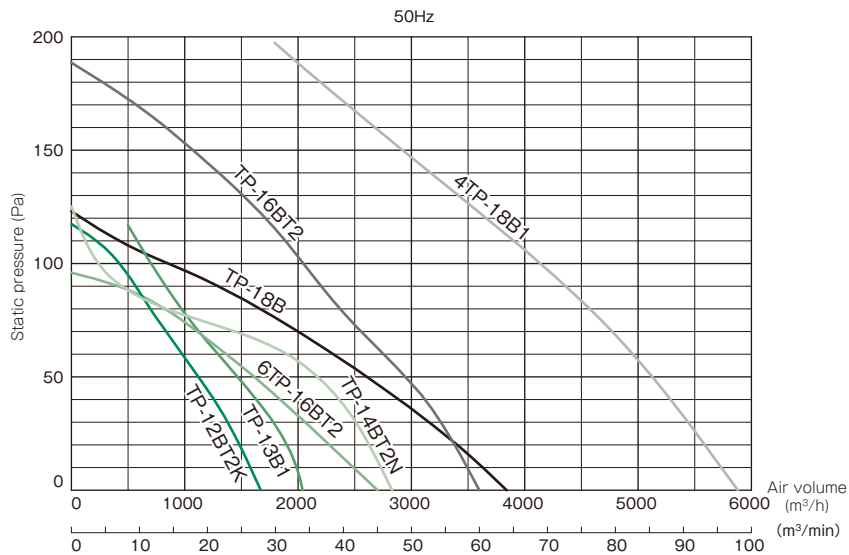

Selection chart

[Exhaust type]

Three-phase, impeller diameter from 30 to 45cm

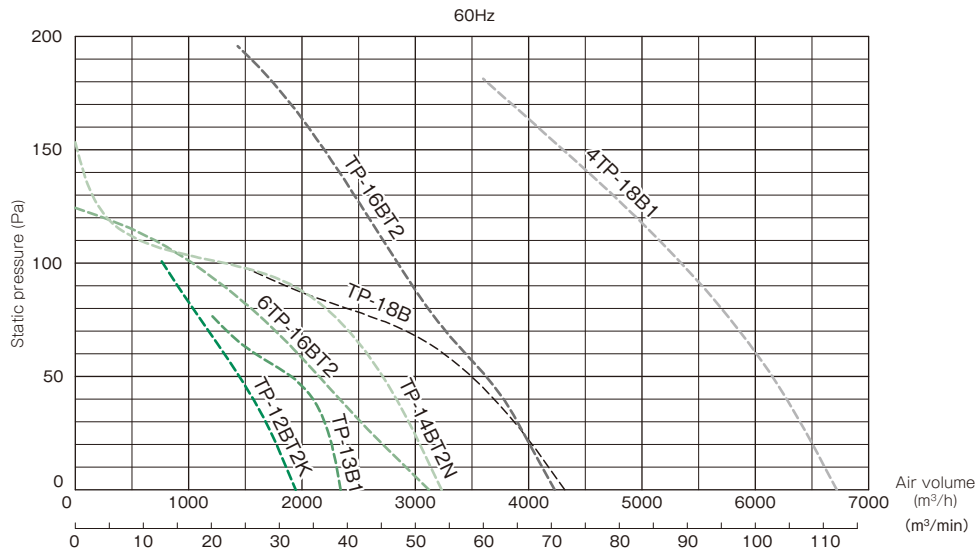

Assembly drawing

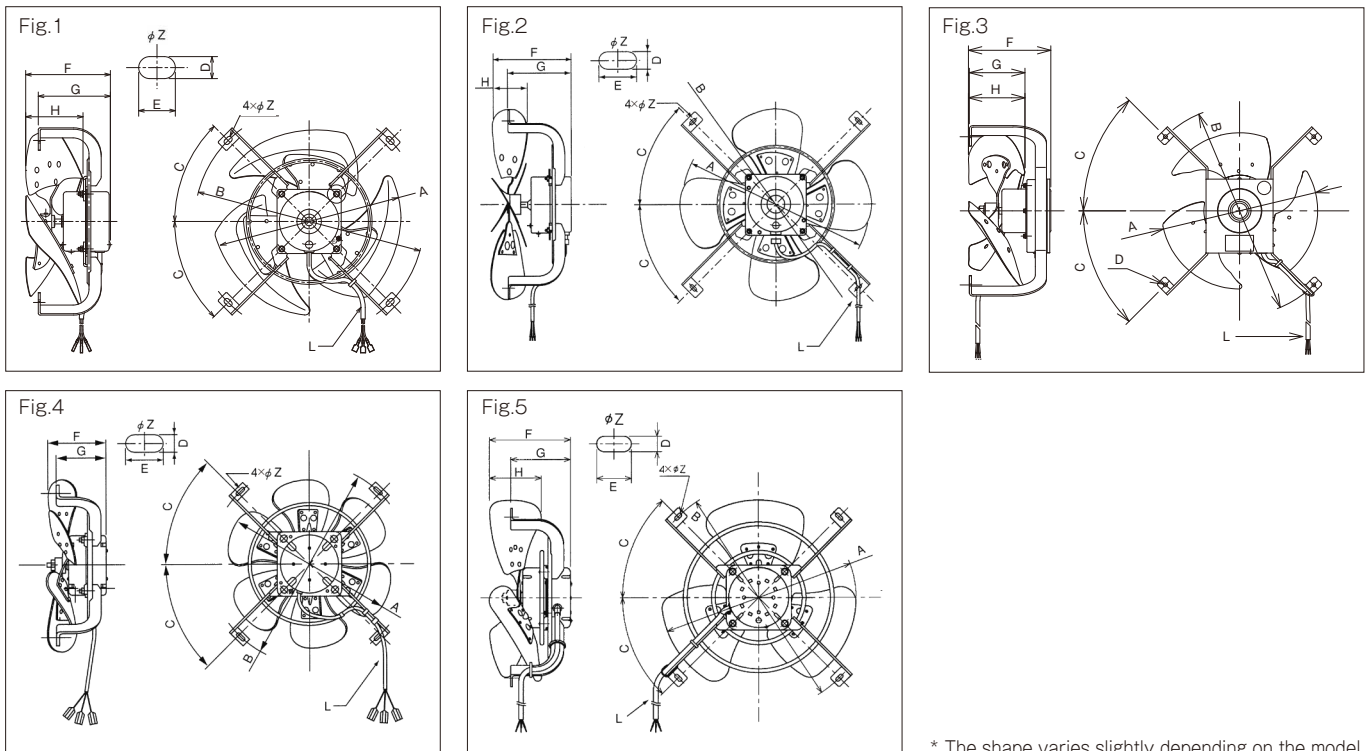

* The shape varies slightly depending on the model.

Dimensions

(Unit:mm)

Fig.	Model	A	B	C	D	E	F	G	H	L
1	TP-12BT2K	300	375	45°	9	15	137	109	102	XLPE×3 cores×0.5mm ² ×2m
2	TP-13B-1	330	410	45°	7	12	142	116	63	XLPE×3 cores×0.75mm ² ×2m
3	TP-14BT2N	350	470	45°	4×φ8.4	/	184.7	124.4	126.5	VCT×3 cores×0.75mm ² ×1m
4	TP-16BT2	400	477	45°	9	20	137	120	/	XLPE×3 cores×0.75mm ² ×1.5m
	6TP-16BT2	400	477	45°	9	20	141	120	/	XLPE×3 cores×0.75mm ² ×1.5m
5	4TP-18B1	450	527	45°	9	20	185	138	120	2PNCT×3 cores×0.75mm ² ×3.8m
4	TP-18B	450	527	45°	9	20	143	128	/	XLPE×3 cores×0.75mm ² ×2m

Applications

For cubicles, important machinery, and other places where failure alarms are required

Feature

These pressure fans are ideal for cooling important equipment requiring fan failure alarms, such as cubicles, communications equipment, and transformers. They are equipped with centrifugal contact switches so that signals can be output when fan revolutions decrease to 70 to 80% or less for some reason.

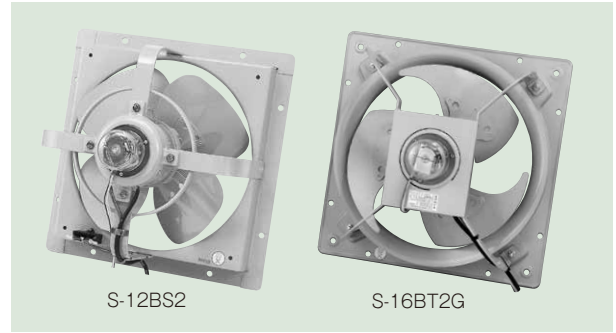

* Please note that the photo shows typical examples and that they may partly differ from actual items.

Specification table

Airflow direction	Model	Impeller diameter (cm)	Number of poles (P)	Power supply (V)	Nominal output (W)	Air volume (m³/h)		Power consumption (W)		Allowable current (A)		Starting current (A)		Noise (dB(A))		Approx. mass (kg)
						50Hz	60Hz	50Hz	60Hz	50Hz	60Hz	50Hz	60Hz	50Hz	60Hz	
Exhaust type	S-10BS2	25	4	Single-phase200	20	570	690	40	45	0.4	0.4	0.57	0.52	45	49	6
	S-12BS2	30			50	1098	1296	56	68	0.6	0.5	1.1	1	51	55	8
	S-14BS2G	35			100	2660	3150	142	144	1.6	1.5	4.3	4.2	43.5	47	9.8
	S-14BT2G							102	122	1.25	1.15	4.1	3.9			
	S-16BS2G	40	Single-phase200	200	4080	4680	200	250	1.8	1.8	4.3	4.2	46	50	11.5	
	S-16BT2G				4022	4543	162	227	1.2	1.2	4.1	3.9				
	S-18BT2A	45	6	Three-phase200	250	5034	5802	210	310	2.3	3.0	6.5	5.7	54	58	23.5
	S-20BT2G	50			400	6120	7140	270	410	2.6	2.8	6.5	5.7	49	53	25
	S-24BT2G	60			750	9420	11160	460	690	4.2	4.2	12	10	51	55.5	33.5

- The power consumption, air volume and noise figures mentioned above represent the values in the state of operation under free air conditions.
- The air volume has been measured using the JIS C 9603-compliant orifice chamber method.
- The noise figure represents the average of the values measured at three points that are 1.5 meters distant from one another. The value in actual operation varies depending on the installation method, the duct form, and so on.
- The allowable current figure represents the critical point of operation. Use it for reference at the time of selecting a motor breaker.
- Make sure that the product is used in a place where no corrosive or explosive gas or no steam is generated.
- The fan should be installed in an environment where the temperature ranges from -20 °C to +50 °C, the humidity is 85% or less, and the elevation is 1,000m or less. Observe these conditions when using the product.

Special Specifications

Impeller diameter (cm)	Special order features						
	Different voltage 210V or 215V	Different voltage 400V	Heat resistance of 60 °C	Heat resistance of 80 °C	Acid-resistant (salt-resistant) coating	Specified color	MFP treatment
25	×	×	○	×	○	○	×
30	×	×	○	×	○	○	×
35	×	*1	○	×	○	○	×
40	○	*1	○	×	○	○	×
45	○	*1	○	×	○	○	×
50	○	*1	○	×	○	○	×
60	○	*1	○	×	○	○	×

*1: 400V class available for three-phase power supply models only

Selection chart

[Exhaust type]

Single-phase, impeller diameter from 25 to 40cm

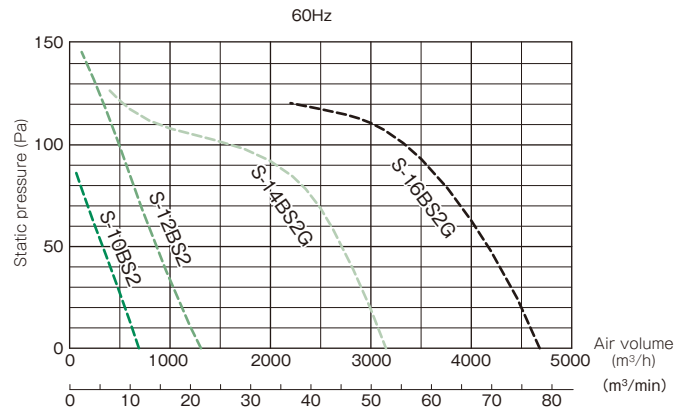
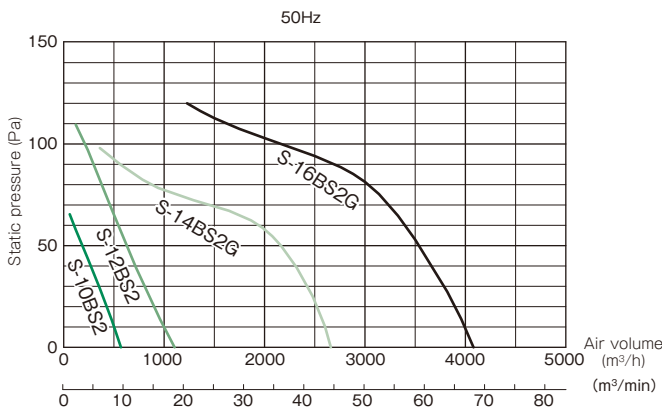

Selection chart

[Exhaust type]

Three-phase, impeller diameter from 35 to 60cm

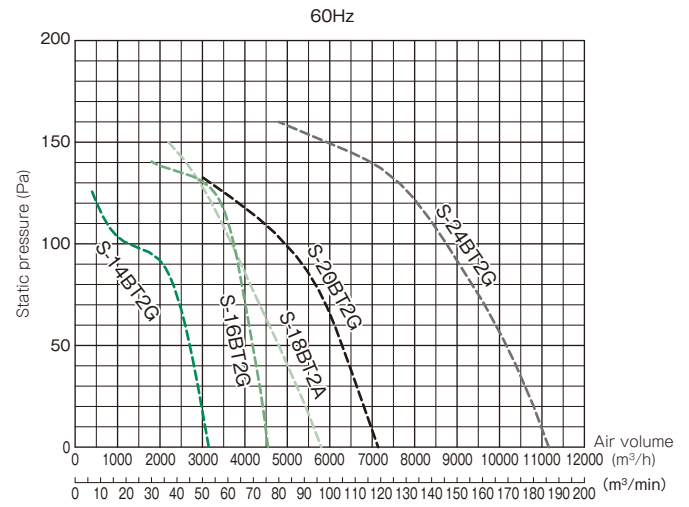
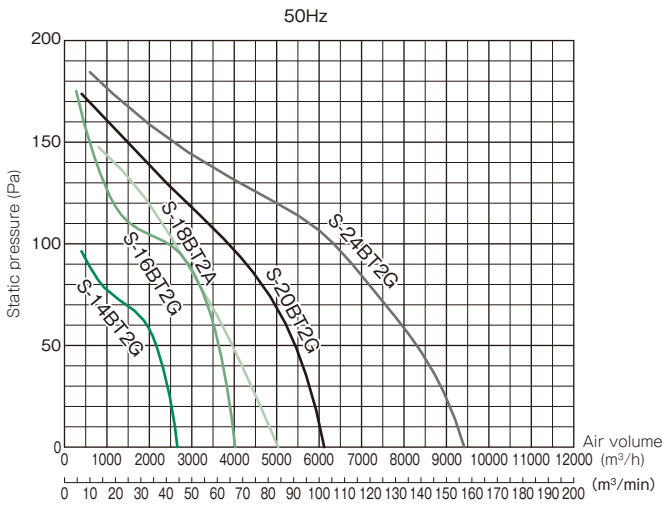

Assembly drawing

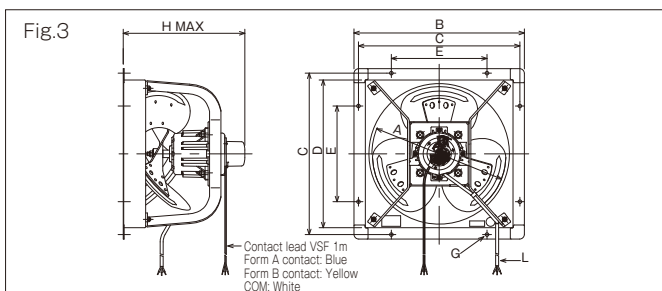
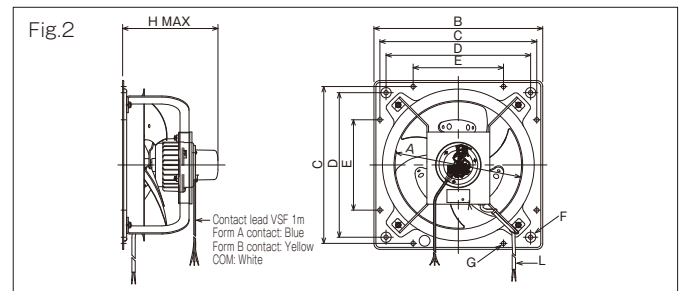
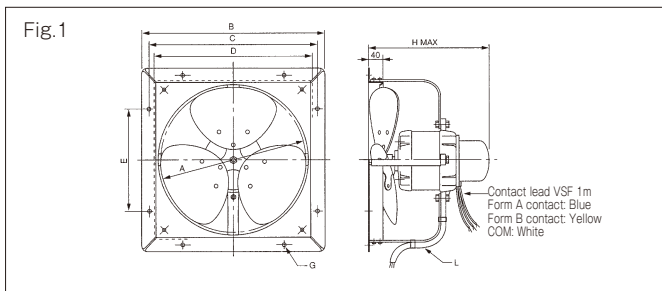

* The shape varies slightly depending on the model.

Dimensions

(Unit:mm)

Fig.	Model	A	B	C	D	E	F	G	H	L
1	S-10BS2	250	327	298	271	165	/	8×φ7	245	2PNCT×2 cores×0.75mm ² ×1m
	S-12BS2	300	378	349	322	210	/	8×φ7	260	2PNCT×2 cores×0.75mm ² ×1m
2	S-14BS2G	350	467	434	400	250	4×φ12	8×φ12	264	2PNCT×2 cores×0.75mm ² ×1m
	S-14BT2G	350	467	434	400	250	4×φ12	8×φ12	264	2PNCT×3 cores×0.75mm ² ×1m
	S-16BS2G	400	518	485	450	280	4×φ12	8×φ12	269	2PNCT×2 cores×0.75mm ² ×1m
3	S-16BT2G	400	518	485	450	280	4×φ12	8×φ12	269	2PNCT×3 cores×0.75mm ² ×1m
	S-18BT2A	450	570	540	494	320	/	8×φ12	420	2PNCT×3 cores×1.25mm ² ×1m
2	S-20BT2G	500	659	620	563	355	/	8×φ15	435	2PNCT×3 cores×1.25mm ² ×1m
	S-24BT2G	600	760	720	664	400	/	8×φ15	450	2PNCT×3 cores×1.25mm ² ×1m

Standard Type

Model	Impeller diameter of compatible pressure fans	Airflow direction	Mounting frame	Fixed louver		Wind pressure shutter		Motor-driven shutter		Guard net			Filter unit
				Steel plate	SUS	Steel plate	SUS	Steel plate	SUS	Iron	SUS	Front face net	
PF	20 cm	Exhaust	TWBS- 8	LB- 8C	LBS- 8C	PS- 8C	PSS- 8C	—	—	GN- 8D1	—	FGN- 8	3FU- 8A
		Intake	TWBS- 8	LB- 8C	LBS- 8C	—	—	—	—	GN- 8D1	—	FGN- 8	3FU- 8A
	25 cm	Exhaust	TWBS-10	LB-10C	LBS-10C	PS-10C	PSS-10C	MS-10D	MSS-10D	GN-10D1	GNS-10D1	FGN-10	3FU-10A
		Intake	TWBS-10	LB-10C	LBS-10C	—	—	MS-10D	MSS-10D	GN-10D1	GNS-10D1	FGN-10	3FU-10A
	30 cm	Exhaust	TWBS-12	LB-12C	LBS-12C	PS-12C	PSS-12C	MS-12D	MSS-12D	GN-12D1	GNS-12D1	FGN-12	3FU-12A
		Intake	TWBS-12	LB-12C	LBS-12C	—	—	MS-12D	MSS-12D	GN-12D1	GNS-12D1	FGN-12	3FU-12A
	35 cm	Exhaust	TWBS-14	LB-14C	LBS-14C	PS-14C	PSS-14C	MS-14D	MSS-14D	GN-14G	GNS-14G	FGN-14	3FU-14A
		Intake	TWBS-14	LB-14C	LBS-14C	—	—	MS-14D	MSS-14D	GN-14G	GNS-14G	FGN-14	3FU-14A
	40 cm	Exhaust	TWBS-16	LB-16C	LBS-16C	4P PS-16C 6P 6PS-16	4P PSS-16C 6P 6PSS-16	MS-16D	MSS-16D	GN-16G.G1*1	GNS-16G*2	FGN-16	3FU-16A
		Intake	TWBS-16	LB-16C	LBS-16C	—	—	MS-16D	MSS-16D	GN-16G.G1*1	GNS-16G*2	FGN-16	3FU-16A
	45 cm	Exhaust	TWBS-18	LB-18C	LBS-18C	PS-18C	PSS-18C	MS-18C/D	MSS-18C/D	GN-18A-3	GNS-18	FGN-18	3FU-18A
		Intake	TWBS-18	LB-18C	LBS-18C	—	—	MS-18C/D	MSS-18C/D	GN-18A-3	GNS-18	FGN-18	3FU-18A
	50 cm	Exhaust	TWBS-20	LB-20C	LBS-20C	PS-20C	PSS-20C	MS-20C/D	MSS-20C/D	GN-20A-3	GNS-20A	FGN-20	3FU-20A
		Intake	TWBS-20	LB-20C	LBS-20C	—	—	MS-20C/D	MSS-20C/D	GN-20A-3	GNS-20A	FGN-20	3FU-20A
	60 cm	Exhaust	TWBS-24	LB-24C	LBS-24C	6P PS-24C 8P 8PS-24	6P PSS-24C 8P 8PSS-24	MS-24D	MSS-24D	GN-24A-3	GNS-24A	FGN-24	3FU-24A
		Intake	TWBS-24	LB-24C	LBS-24C	—	—	MS-24D	MSS-24D	GN-24A-3	GNS-24A	FGN-24	3FU-24A
	75 cm	Exhaust	TWBS-30	LB-30C	LBS-30C	PS-30C	PSS-30C	MS-30D	MSS-30D	GN-30S	GNS-30	FGN-30	3FU-30A/B
		Intake	TWBS-30	LB-30C	LBS-30C	—	—	MS-30D	MSS-30D	GN-30S	GNS-30	FGN-30	3FU-30A/B
	90 cm	Exhaust	TWBS-36	LB-36C	LBS-36C	PS-36C	PSS-36C	MS-36D	MSS-36D	GN-36S	GNS-36	FGN-36	3FU-36A/B
		Intake	TWBS-36	LB-36C	LBS-36C	—	—	MS-36D	MSS-36D	GN-36S	GNS-36	FGN-36	3FU-36A/B
105 cm	Exhaust	TWBS-42	LB-42C	LBS-42C	PS-42C	PSS-42C	MS-42D	MSS-42D	GN-42SG	GNS-42SG	FGN-42	—	
	Intake	TWBS-42	LB-42C	LBS-42C	—	—	MS-42D	MSS-42D	GN-42SG	GNS-42SG	FGN-42	—	
120 cm	Exhaust	—	LB-48	LBS-48	—	—	—	—	GN-48	—	FGN-48	—	
	Intake	—	LB-48	LBS-48	—	—	—	—	GN-48	—	FGN-48	—	

Note: Check the specifications of and models compatible with optional accessories prior to selection. Some products may not be used depending on the operating environment. They may not be combined with some special pressure fan models.

* For outdoor hoods with a motor-driven shutter (built-in), please contact us.

*1: Holed type GN-16G1 is for PF-16B(A) T2F, and GN-16G is for other models.

*2: For PF-16B(A) T2F, please contact us.

Model	Impeller diameter of compatible pressure fans	Airflow direction	Outdoor hood							Fireproof hood			
			Without net		With anti-insect net			With anti-bird net		Without net	With anti-insect net	With anti-bird net	
			Steel plate	SUS	Steel plate	SUS	SUS (with rainwater gutter)	Steel plate	SUS	SUS (with rainwater gutter)	SUS		
PF	20 cm	Exhaust	OF- 8	OFS- 8	OF- 8NI	OFS- 8NI	—	OF- 8NB	OFS- 8NB	—	—	—	—
		Intake	—	—	—	—	OFS- 8ANI	—	—	OFS- 8ANB	—	—	—
	25 cm	Exhaust	OF-10	OFS-10	OF-10NI	OFS-10NI	—	OF-10NB	OFS-10NB	—	—	—	—
		Intake	—	—	—	—	OFS-10ANI	—	—	OFS-10ANB	—	—	—
	30 cm	Exhaust	OF-12	OFS-12	OF-12NI	OFS-12NI	—	OF-12NB	OFS-12NB	—	FDS-12	FDS-12NI	FDS-12NB
		Intake	—	—	—	—	OFS-12ANI	—	—	OFS-12ANB	—	—	—
	35 cm	Exhaust	OF-14	OFS-14	OF-14NI	OFS-14NI	—	OF-14NB	OFS-14NB	—	FDS-14	FDS-14NI	FDS-14NB
		Intake	—	—	—	—	OFS-14ANI	—	—	OFS-14ANB	—	—	—
	40 cm	Exhaust	OF-16	OFS-16	OF-16NI	OFS-16NI	—	OF-16NB	OFS-16NB	—	FDS-16	FDS-16NI	FDS-16NB
		Intake	—	—	—	—	OFS-16ANI	—	—	OFS-16ANB	—	—	—
	45 cm	Exhaust	OF-18	OFS-18	OF-18NI	OFS-18NI	—	OF-18NB	OFS-18NB	—	FDS-18	FDS-18NI	FDS-18NB
		Intake	—	—	—	—	OFS-18ANI	—	—	OFS-18ANB	—	—	—
	50 cm	Exhaust	OF-20	OFS-20	OF-20NI	OFS-20NI	—	OF-20NB	OFS-20NB	—	FDS-20	FDS-20NI	FDS-20NB
		Intake	—	—	—	—	OFS-20ANI	—	—	OFS-20ANB	—	—	—
	60 cm	Exhaust	OF-24	OFS-24	OF-24NI	OFS-24NI	—	OF-24NB	OFS-24NB	—	FDS-24	FDS-24NI	FDS-24NB
		Intake	—	—	—	—	OFS-24ANI	—	—	OFS-24ANB	—	—	—
	75 cm	Exhaust	OF-30	OFS-30	OF-30NI	OFS-30NI	—	OF-30NB	OFS-30NB	—	FDS-30	FDS-30NI	FDS-30NB
		Intake	—	—	—	—	OFS-30ANI	—	—	OFS-30ANB	—	—	—
	90 cm	Exhaust	OF-36	OFS-36	OF-36NI	OFS-36NI	—	OF-36NB	OFS-36NB	—	FDS-36	FDS-36NI	FDS-36NB
		Intake	—	—	—	—	OFS-36ANI	—	—	OFS-36ANB	—	—	—
105 cm	Exhaust	OF-42	OFS-42	OF-42NI	OFS-42NI	—	OF-42NB	OFS-42NB	—	FDS-42	FDS-42NI	FDS-42NB	
	Intake	—	—	—	—	OFS-42ANI	—	—	OFS-42ANB	—	—	—	
120 cm	Exhaust	OF-48	OFS-48	OF-48NI	OFS-48NI	—	OF-48NB	OFS-48NB	—	—	—	—	
	Intake	—	—	—	—	OFS-48ANI	—	—	OFS-48ANB	—	—	—	

Note: Check the specifications of and models compatible with optional accessories prior to selection. Some products may not be used depending on the operating environment. They may not be combined with some special pressure fan models.

* For outdoor hoods with a motor-driven shutter (built-in), please contact us.

Outdoor Type

Model	Impeller diameter of compatible pressure fans	Airflow direction	Mounting frame	Fixed louver		Wind pressure shutter		Motor-driven shutter		Guard net			Filter unit
				Steel plate	SUS	Steel plate	SUS	Steel plate	SUS	Iron	SUS	Front face net	
WP	25 cm	Exhaust	TWBS-10	LB-10C	LBS-10C	—	—	—	—	GN-10	GNS-10	FGN-10	—
		Intake	TWBS-10	LB-10C	LBS-10C	—	—	—	—	GN-10	GNS-10	FGN-10	—
	30 cm	Exhaust	TWBS-12	LB-12C	LBS-12C	—	—	—	—	GN-12	GNS-12	FGN-12	—
		Intake	TWBS-12	LB-12C	LBS-12C	—	—	—	—	GN-12	GNS-12	FGN-12	—
	35 cm	Exhaust	TWBS-14	LB-14C	LBS-14C	—	—	—	—	GN-14G,G1*1	GNS-14G*2	FGN-14	—
		Intake	TWBS-14	LB-14C	LBS-14C	—	—	—	—	GN-14G,G1*1	GNS-14G*2	FGN-14	—
	40 cm	Exhaust	TWBS-16	LB-16C	LBS-16C	—	—	—	—	GN-16G,G1*1	GNS-16G*2	FGN-16	—
		Intake	TWBS-16	LB-16C	LBS-16C	—	—	—	—	GN-16G,G1*1	GNS-16G*2	FGN-16	—
	45 cm	Exhaust	TWBS-18	LB-18C	LBS-18C	—	—	—	—	GN-18A-3	GNS-18	FGN-18	—
		Intake	TWBS-18	LB-18C	LBS-18C	—	—	—	—	GN-18A-3	GNS-18	FGN-18	—
	50 cm	Exhaust	TWBS-20	LB-20C	LBS-20C	—	—	—	—	GN-20A-3	GNS-20A	FGN-20	—
		Intake	TWBS-20	LB-20C	LBS-20C	—	—	—	—	GN-20A-3	GNS-20A	FGN-20	—
	60 cm	Exhaust	TWBS-24	LB-24C	LBS-24C	—	—	—	—	GN-24A-3	GNS-24A	FGN-24	—
		Intake	TWBS-24	LB-24C	LBS-24C	—	—	—	—	GN-24A-3	GNS-24A	FGN-24	—
	75 cm	Exhaust	TWBS-30	LB-30C	LBS-30C	—	—	—	—	GN-30S	GNS-30	FGN-30	—
		Intake	TWBS-30	LB-30C	LBS-30C	—	—	—	—	GN-30S	GNS-30	FGN-30	—
	90 cm	Exhaust	TWBS-36	LB-36C	LBS-36C	—	—	—	—	GN-36S	GNS-36	FGN-36	—
		Intake	TWBS-36	LB-36C	LBS-36C	—	—	—	—	GN-36S	GNS-36	FGN-36	—
	105 cm	Exhaust	TWBS-42	LB-42C	LBS-42C	—	—	—	—	GN-42SG	GNS-42SG	FGN-42	—
		Intake	TWBS-42	LB-42C	LBS-42C	—	—	—	—	GN-42SG	GNS-42SG	FGN-42	—
	120 cm	Exhaust	—	LB-48	LBS-48	—	—	—	—	GN-48	—	FGN-48	—
		Intake	—	LB-48	LBS-48	—	—	—	—	GN-48	—	FGN-48	—

Note: Check the specifications of and models compatible with optional accessories prior to selection. Some products may not be used depending on the operating environment. They may not be combined with some special pressure fan models.

* For outdoor hoods with a motor-driven shutter (built-in), please contact us.

*1: The GN-14G1 and the GN-16G1 having a bypass hole are for single-phase power supply models, and the GN-14G and the GN-16G are for three-phase power supply models.

*2: For single-phase power supply models, please contact us.

Model	Impeller diameter of compatible pressure fans	Airflow direction	Outdoor hood							Fireproof hood			
			Without net		With anti-insect net			With anti-bird net		Without net	With anti-insect net	With anti-bird net	
			Steel plate	SUS	Steel plate	SUS	SUS (with rainwater gutter)	Steel plate	SUS	SUS (with rainwater gutter)	SUS		
WP	25 cm	Exhaust	OF-10	OFS-10	OF-10NI	OFS-10NI	—	OF-10NB	OFS-10NB	—	—	—	—
		Intake	—	—	—	—	OFS-10ANI	—	—	OFS-10ANB	—	—	—
	30 cm	Exhaust	OF-12	OFS-12	OF-12NI	OFS-12NI	—	OF-12NB	OFS-12NB	—	FDS-12	FDS-12NI	FDS-12NB
		Intake	—	—	—	—	OFS-12ANI	—	—	OFS-12ANB	—	—	—
	35 cm	Exhaust	OF-14	OFS-14	OF-14NI	OFS-14NI	—	OF-14NB	OFS-14NB	—	FDS-14	FDS-14NI	FDS-14NB
		Intake	—	—	—	—	OFS-14ANI	—	—	OFS-14ANB	—	—	—
	40 cm	Exhaust	OF-16	OFS-16	OF-16NI	OFS-16NI	—	OF-16NB	OFS-16NB	—	FDS-16	FDS-16NI	FDS-16NB
		Intake	—	—	—	—	OFS-16ANI	—	—	OFS-16ANB	—	—	—
	45 cm	Exhaust	OF-18	OFS-18	OF-18NI	OFS-18NI	—	OF-18NB	OFS-18NB	—	FDS-18	FDS-18NI	FDS-18NB
		Intake	—	—	—	—	OFS-18ANI	—	—	OFS-18ANB	—	—	—
	50 cm	Exhaust	OF-20	OFS-20	OF-20NI	OFS-20NI	—	OF-20NB	OFS-20NB	—	FDS-20	FDS-20NI	FDS-20NB
		Intake	—	—	—	—	OFS-20ANI	—	—	OFS-20ANB	—	—	—
	60 cm	Exhaust	OF-24	OFS-24	OF-24NI	OFS-24NI	—	OF-24NB	OFS-24NB	—	FDS-24	FDS-24NI	FDS-24NB
		Intake	—	—	—	—	OFS-24ANI	—	—	OFS-24ANB	—	—	—
	75 cm	Exhaust	OF-30	OFS-30	OF-30NI	OFS-30NI	—	OF-30NB	OFS-30NB	—	FDS-30	FDS-30NI	FDS-30NB
		Intake	—	—	—	—	OFS-30ANI	—	—	OFS-30ANB	—	—	—
	90 cm	Exhaust	OF-36	OFS-36	OF-36NI	OFS-36NI	—	OF-36NB	OFS-36NB	—	FDS-36	FDS-36NI	FDS-36NB
		Intake	—	—	—	—	OFS-36ANI	—	—	OFS-36ANB	—	—	—
	105 cm	Exhaust	OF-42	OFS-42	OF-42NI	OFS-42NI	—	OF-42NB	OFS-42NB	—	FDS-42	FDS-42NI	FDS-42NB
		Intake	—	—	—	—	OFS-42ANI	—	—	OFS-42ANB	—	—	—
	120 cm	Exhaust	OF-48	OFS-48	OF-48NI	OFS-48NI	—	OF-48NB	OFS-48NB	—	—	—	—
		Intake	—	—	—	—	OFS-48ANI	—	—	OFS-48ANB	—	—	—

Note: Check the specifications of and models compatible with optional accessories prior to selection. Some products may not be used depending on the operating environment. They may not be combined with some special pressure fan models.

* For outdoor hoods with a motor-driven shutter (built-in), please contact us.

■ Pressure-Resistant Explosion-Proof Type

Model	Impeller diameter of compatible pressure fans	Airflow direction	Mounting frame	Fixed louver		Wind pressure shutter		Motor-driven shutter		Guard net			Filter unit
				Steel plate	SUS	Steel plate	SUS	Steel plate	SUS	Iron	SUS	Front face net	
EPP	20cm	Exhaust	TWBS-8	LB-8C	LBS-8C	PS-8C	PSS-8C	—	—	EGN-8	—	FGN-8	3FU-8A
	25cm	Exhaust	TWBS-10	LB-10C	LBS-10C	PS-10C	PSS-10C	—	—	EGN-10	—	FGN-10	3FU-10A
		Intake	TWBS-10	LB-10C	LBS-10C	—	—	—	—	EGN-10	—	FGN-10	3FU-10A
	30cm	Exhaust	TWBS-12	LB-12C	LBS-12C	PS-12C	PSS-12C	—	—	EGN-12	—	FGN-12	3FU-12A
		Intake	TWBS-12	LB-12C	LBS-12C	—	—	—	—	EGN-12	—	FGN-12	3FU-12A
	35cm	Exhaust	TWBS-14	LB-14C	LBS-14C	PS-14C	PSS-14C	—	—	EGN-14	—	FGN-14	3FU-14A
		Intake	TWBS-14	LB-14C	LBS-14C	—	—	—	—	EGN-14	—	FGN-14	3FU-14A
	40cm	Exhaust	TWBS-16	LB-16C	LBS-16C	4P PS-16C 6P 6PS-16	4P PSS-16C 6P 6PSS-16	—	—	EGN-16	—	FGN-16	3FU-16A
		Intake	TWBS-16	LB-16C	LBS-16C	—	—	—	—	EGN-16	—	FGN-16	3FU-16A
	45cm	Exhaust	TWBS-18	LB-18C	LBS-18C	PS-18C	PSS-18C	—	—	EGN-18	—	FGN-18	3FU-18A
		Intake	TWBS-18	LB-18C	LBS-18C	—	—	—	—	EGN-18	—	FGN-18	3FU-18A
	50cm	Exhaust	TWBS-20	LB-20C	LBS-20C	PS-20C	PSS-20C	—	—	EGN-20	—	FGN-20	3FU-20A
		Intake	TWBS-20	LB-20C	LBS-20C	—	—	—	—	EGN-20	—	FGN-20	3FU-20A
	60cm	Exhaust	TWBS-24	LB-24C	LBS-24C	6P PS-24C 8P 8PS-24	6P PSS-24C 8P 8PSS-24	—	—	EGN-24	—	FGN-24	3FU-24A
	75cm	Exhaust	TWBS-30	LB-30C	LBS-30C	PS-30C	PSS-30C	—	—	EGN-30	—	FGN-30	3FU-30A/B
	90cm	Exhaust	TWBS-36	LB-36C	LBS-36C	PS-36C	PSS-36C	—	—	EGN-36	—	FGN-36	3FU-36A/B
105cm	Exhaust	TWBS-42	LB-42C	LBS-42C	PS-42C	PSS-42C	—	—	EGN-42	—	FGN-42	—	
120cm	Exhaust	—	LB-48	LBS-48	—	—	—	—	EGN-48	—	FGN-48	—	

Note: Check the specifications of and models compatible with optional accessories prior to selection. Some products may not be used depending on the operating environment. They may not be combined with some special pressure fan models.

Model	Impeller diameter of compatible pressure fans	Airflow direction	Outdoor hood							Fireproof hood			
			Without net		With anti-insect net			With anti-bird net		Without net	With anti-insect net	With anti-bird net	
			Steel plate	SUS	Steel plate	SUS	SUS (with rainwater gutter)	Steel plate	SUS	SUS (with rainwater gutter)	SUS		
EPP	20cm	Exhaust	OF-8	OFS-8	OF-8NI	OFS-8NI	—	OF-8NB	OFS-8NB	—	—	—	—
	25cm	Exhaust	OF-10	OFS-10	OF-10NI	OFS-10NI	—	OF-10NB	OFS-10NB	—	—	—	—
		Intake	—	—	—	—	OFS-10ANI	—	—	OFS-10ANB	—	—	—
	30cm	Exhaust	OF-12	OFS-12	OF-12NI	OFS-12NI	—	OF-12NB	OFS-12NB	—	FDS-12	FDS-12NI	FDS-12NB
		Intake	—	—	—	—	OFS-12ANI	—	—	OFS-12ANB	—	—	—
	35cm	Exhaust	OF-14	OFS-14	OF-14NI	OFS-14NI	—	OF-14NB	OFS-14NB	—	FDS-14	FDS-14NI	FDS-14NB
		Intake	—	—	—	—	OFS-14ANI	—	—	OFS-14ANB	—	—	—
	40cm	Exhaust	OF-16	OFS-16	OF-16NI	OFS-16NI	—	OF-16NB	OFS-16NB	—	FDS-16	FDS-16NI	FDS-16NB
		Intake	—	—	—	—	OFS-16ANI	—	—	OFS-16ANB	—	—	—
	45cm	Exhaust	OF-18	OFS-18	OF-18NI	OFS-18NI	—	OF-18NB	OFS-18NB	—	FDS-18	FDS-18NI	FDS-18NB
		Intake	—	—	—	—	OFS-18ANI	—	—	OFS-18ANB	—	—	—
	50cm	Exhaust	OF-20	OFS-20	OF-20NI	OFS-20NI	—	OF-20NB	OFS-20NB	—	FDS-20	FDS-20NI	FDS-20NB
		Intake	—	—	—	—	OFS-20ANI	—	—	OFS-20ANB	—	—	—
	60cm	Exhaust	OF-24	OFS-24	OF-24NI	OFS-24NI	—	OF-24NB	OFS-24NB	—	FDS-24	FDS-24NI	FDS-24NB
	75cm	Exhaust	OF-30	OFS-30	OF-30NI	OFS-30NI	—	OF-30NB	OFS-30NB	—	FDS-30	FDS-30NI	FDS-30NB
	90cm	Exhaust	OF-36	OFS-36	OF-36NI	OFS-36NI	—	OF-36NB	OFS-36NB	—	FDS-36	FDS-36NI	FDS-36NB
105cm	Exhaust	OF-42	OFS-42	OF-42NI	OFS-42NI	—	OF-42NB	OFS-42NB	—	FDS-42	FDS-42NI	FDS-42NB	
120cm	Exhaust	OF-48	OFS-48	OF-48NI	OFS-48NI	—	OF-48NB	OFS-48NB	—	—	—	—	

Note: Check the specifications of and models compatible with optional accessories prior to selection. Some products may not be used depending on the operating environment. They may not be combined with some special pressure fan models.

■ Stainless Steel Type

Model	Impeller diameter of compatible pressure fans	Airflow direction	Mounting frame	Fixed louver		Wind pressure shutter		Motor-driven shutter		Guard net			Filter unit
				Steel plate	SUS	Steel plate	SUS	Steel plate	SUS	Iron	SUS	Front face net	
PFS	25cm	Exhaust	TWBS-10	—	LBS-10C	—	PSS-10C	—	MSS-10D	—	GNS-10D1	—	—
	30cm	Exhaust	TWBS-12	—	LBS-12C	—	PSS-12C	—	MSS-12D	—	GNS-12D1	—	—
	40cm	Exhaust	TWBS-16	—	LBS-16C	—	PSS-16C	—	MSS-16D	—	GNS-16G	—	—
	50cm	Exhaust	TWBS-20	—	LBS-20C	—	PSS-20C	—	MSS-20D	—	GNS-20A	—	—

Note: Check the specifications of and models compatible with optional accessories prior to selection. Some products may not be used depending on the operating environment. They may not be combined with some special pressure fan models.

* For outdoor hoods with a motor-driven shutter (built-in), please contact us.

Model	Impeller diameter	Airflow direction	Outdoor hood							Fireproof hood			
			Without net		With anti-insect net			With anti-bird net		Without net	With anti-insect net	With anti-bird net	
			Steel plate	SUS	Steel plate	SUS	SUS (with rainwater gutter)	Steel plate	SUS	SUS (with rainwater gutter)	SUS		
PFS	25cm	Exhaust	—	OFS-10	—	OFS-10NI	—	—	OFS-10NB	—	—	—	—
	30cm	Exhaust	—	OFS-12	—	OFS-12NI	—	—	OFS-12NB	—	FDS-12	FDS-12NI	FDS-12NB
	40cm	Exhaust	—	OFS-16	—	OFS-16NI	—	—	OFS-16NB	—	FDS-16	FDS-16NI	FDS-16NB
	50cm	Exhaust	—	OFS-20	—	OFS-20NI	—	—	OFS-20NB	—	FDS-20	FDS-20NI	FDS-20NB

Note: Check the specifications of and models compatible with optional accessories prior to selection. Some products may not be used depending on the operating environment. They may not be combined with some special pressure fan models.

* For outdoor hoods with a motor-driven shutter (built-in), please contact us.

* Please contact us for intake type.

■ All Stainless Steel Type

Centrifugal Contact Type

Model	Impeller diameter of compatible pressure fans	Airflow direction	Mounting frame	Fixed louver		Wind pressure shutter		Motor-driven shutter		Guard net			Filter unit
				Steel plate	SUS	Steel plate	SUS	Steel plate	SUS	Iron	SUS	Front face net	
S	25cm	Exhaust	TWBS-10	LB-10C	LBS-10C	PS-10C	PSS-10C	MS-10D	MSS-10D	GN-10	—	FGN-10	3FU-10A
	30cm	Exhaust	TWBS-12	LB-12C	LBS-12C	PS-12C	PSS-12C	MS-12D	MSS-12D	GN-12	—	FGN-12	3FU-12A
	35cm	Exhaust	TWBS-14	LB-14C	LBS-14C	PS-14C	PSS-14C	MS-14D	MSS-14D	GN-14G1	—	FGN-14	3FU-14A
	40cm	Exhaust	TWBS-16	LB-16C	LBS-16C	PS-16C	PSS-16C	MS-16D	MSS-16D	GN-16G1	—	FGN-16	3FU-16A
	45cm	Exhaust	TWBS-18	LB-18C	LBS-18C	PS-18C	PSS-18C	MS-18D	MSS-18D	GN-18A-3	—	FGN-18	3FU-18A
	50cm	Exhaust	TWBS-20	LB-20C	LBS-20C	PS-20C	PSS-20C	MS-20D	MSS-20D	GN-20A-3	—	FGN-20	3FU-20A
	60cm	Exhaust	TWBS-24	LB-24C	LBS-24C	PS-24C	PSS-24C	MS-24D	MSS-24D	GN-24A-3	—	FGN-24	3FU-24A

Note: Check the specifications of and models compatible with optional accessories prior to selection. Some products may not be used depending on the operating environment. They may not be combined with some special pressure fan models.

* For outdoor hoods with a motor-driven shutter (built-in), please contact us.

Model	Impeller diameter of compatible pressure fans	Airflow direction	Outdoor hood							Fireproof hood			
			Without net		With anti-insect net			With anti-bird net		Without net	With anti-insect net	With anti-bird net	
			Steel plate	SUS	Steel plate	SUS	SUS (with rainwater gutter)	Steel plate	SUS	SUS (with rainwater gutter)	SUS		
S	25cm	Exhaust	OF-10	OFS-10	OF-10NI	OFS-10NI	—	OF-10NB	OFS-10NB	—	—	—	—
	30cm	Exhaust	OF-12	OFS-12	OF-12NI	OFS-12NI	—	OF-12NB	OFS-12NB	—	FDS-12	FDS-12NI	FDS-12NB
	35cm	Exhaust	OF-14	OFS-14	OF-14NI	OFS-14NI	—	OF-14NB	OFS-14NB	—	FDS-14	FDS-14NI	FDS-14NB
	40cm	Exhaust	OF-16	OFS-16	OF-16NI	OFS-16NI	—	OF-16NB	OFS-16NB	—	FDS-16	FDS-16NI	FDS-16NB
	45cm	Exhaust	OF-18	OFS-18	OF-18NI	OFS-18NI	—	OF-18NB	OFS-18NB	—	FDS-18	FDS-18NI	FDS-18NB
	50cm	Exhaust	OF-20	OFS-20	OF-20NI	OFS-20NI	—	OF-20NB	OFS-20NB	—	FDS-20	FDS-20NI	FDS-20NB
	60cm	Exhaust	OF-24	OFS-24	OF-24NI	OFS-24NI	—	OF-24NB	OFS-24NB	—	FDS-24	FDS-24NI	FDS-24NB

Note: Check the specifications of and models compatible with optional accessories prior to selection. Some products may not be used depending on the operating environment. They may not be combined with some special pressure fan models.

* For outdoor hoods with a motor-driven shutter (built-in), please contact us.

Stainless Steel

Mounting Frames



* Please note that the photo shows typical examples and that they may partly differ from actual items.

Assembly drawing

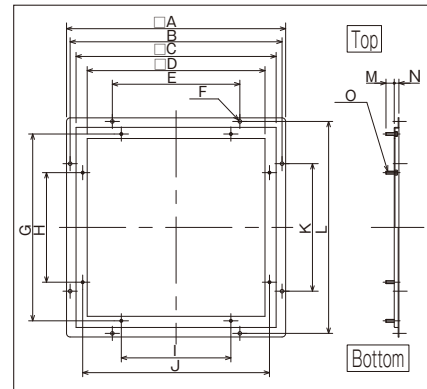

Dimensions

(Unit:mm)

Impeller diameter of compatible pressure fans	Model	A	B	C	D	E	F	G	H	I	J	K	L	M	N	O	Plate thickness	Approx. mass (kg)
20cm	TWBS-8	316	269	276	220	200	8×φ9	—	162	—	246	200	296	24	12	4×M6×25	1	0.6
25cm	TWBS-10	367	347	327	275	200	8×φ9	—	165	—	298	200	347	24	12	4×M6×25	1	0.7
30cm	TWBS-12	418	398	378	325	300	8×φ9	—	210	—	349	300	398	23	12	4×M6×25	2	1.5
35cm	TWBS-14	530	500	467	400	320	8×φ12	—	250	—	434	320	500	28	12	4×M10×30	2	2.5
40cm	TWBS-16	600	560	518	450	350	8×φ12	—	280	—	485	350	560	27.5	14	4×M10×30	2.5	4.0
45cm	TWBS-18	630	600	570	500	400	8×φ12	540	320	320	540	400	600	27.5	14	8×M10×30	2.5	3.9
50cm	TWBS-20	750	710	659	570	450	8×φ15	620	355	355	620	450	710	37	19	8×M12×40	3	7.5
60cm	TWBS-24	820	790	760	670	500	8×φ15	720	400	400	720	500	790	37	19	8×M12×40	3	7.3
75cm	TWBS-30	1020	990	955	840	600	8×φ20	900	508	508	900	600	990	47	19	8×M16×50	3	10.9
90cm	TWBS-36	1220	1180	1114	990	710	8×φ20	1040	610	610	1040	710	1180	46	26	8×M16×50	4	21.3
105cm	TWBS-42	1360	1320	1266	1150	800	8×φ20	1207	656	656	1207	800	1320	46	26	8×M16×50	4	22.4

* Spring washers, Taper washers, and nuts are not included.

Steel Plate Stainless Steel

Fixed Louvers

Serving as a simplified method of blocking incoming wind or covering the air inlet at the time of installing a fan



LB-14C

* Please note that the photo shows typical examples and that they may partly differ from actual items.

Assembly drawing

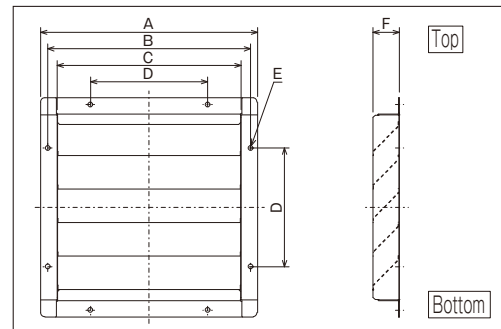

* The shape varies slightly depending on the model.

* It cannot be used where it is directly exposed to rainwater.

Dimensions

(Unit:mm)

Impeller diameter of compatible pressure fans	Model		A	B	C	D	E	F	Number of blades	Approx. mass (kg)
	Steel Plate	Stainless Steel								
20cm	LB-8C	LBS-8C	276	246	217	162	8×φ7	63	3	1.5
25cm	LB-10C	LBS-10C	327	298	268	165	8×φ7	63	4	1.9
30cm	LB-12C	LBS-12C	378	349	319	210	8×φ7	63	5	2.5
35cm	LB-14C	LBS-14C	467	434	389	250	8×φ12	75	5	4.3
40cm	LB-16C	LBS-16C	518	485	440	280	8×φ12	75	6	5.1
45cm	LB-18C	LBS-18C	570	540	492	320	8×φ12	75	6	5.7
50cm	LB-20C	LBS-20C	659	620	562	355	8×φ15	85	6	8.6
60cm	LB-24C	LBS-24C	760	720	663	400	8×φ15	85	7	12.4
75cm	LB-30C	LBS-30C	955	900	832	508	8×φ20	85	9	18
90cm	LB-36C	LBS-36C	1110	1040	980	610	8×φ20	85	9	24
105cm	LB-42C	LBS-42C	1262	1207	1132	656	8×φ20	85	10	28
120cm	LB-48	LBS-48	1475	1425	1345	800	8×φ20	130	13	52

Steel Plate Stainless Steel

Wind Pressure Shutters

Helpful to blocking of incoming wind at the time of installing a fan



PS-18C

- * Check the behavior of the wind pressure shutter after it is installed in a flat state.
- * Use it in an environment where the temperature ranges from -10 °C to +60 °C and the relative humidity is 90% or less.
- * Do not use it where it would be directly exposed to rainwater.
- * It is not compatible with any intake-type pressure fan.
- * The opening/closing angle varies depending on the air volume of the pressure fan used.
- * Use a motor-driven shutter if the air volume is limited.

* Please note that the photo shows typical examples and that they may partly differ from actual items.

Assembly drawing

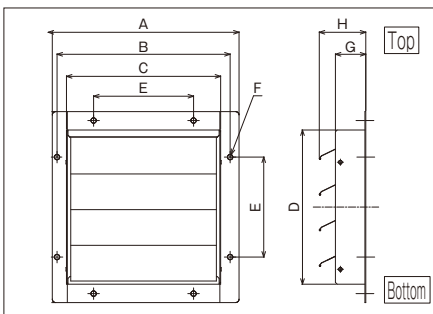

* The shape varies slightly depending on the model.

Dimensions

(Unit:mm)

Impeller diameter of compatible pressure fans	Model		A	B	C	D	E	F	G	H	Number of blades	Approx. mass (kg)
	Steel Plate	Stainless Steel										
20cm	PS-8C	PSS-8C	276	246	220	217	162	8×φ7	63	95	2	1.5
25cm	PS-10C	PSS-10C	327	298	271	268	165	8×φ7	63	95	3	2.1
30cm	PS-12C	PSS-12C	378	349	322	319	210	8×φ7	63	95	3	2.8
35cm	PS-14C	PSS-14C	467	434	392	389	250	8×φ12	75	110	4	4.1
40cm	4P PS-16C	PSS-16C	518	485	443	440	280	8×φ12	75	110	4	4.9
40cm	6P PS-16C	PSS-16C	518	485	440	440	280	8×φ12	75	115	6	2.9
45cm	PS-18C	PSS-18C	570	540	495	492	320	8×φ12	75	110	5	5.8
50cm	PS-20C	PSS-20C	659	620	565	562	355	8×φ15	85	120	5	8.2
60cm	6P PS-24C	PSS-24C	760	720	666	663	400	8×φ15	85	120	6	10.4
60cm	8P PS-24C	PSS-24C	760	720	663	663	400	8×φ15	90	130	9	7.7
75cm	PS-30C	PSS-30C	955	900	833	830	508	8×φ20	85	140	8	17
90cm	PS-36C	PSS-36C	1110	1040	986	983	610	8×φ20	85	140	10	21
105cm	PS-42C	PSS-42C	1262	1207	1136	1133	656	8×φ20	85	140	11	25

Steel Plate Stainless Steel

Motor-Driven Shutters

Incorporating a high-performance drive motor to guarantee unfailing operations; for blocking incoming wind or in combination with the air inlet or an intake-type pressure fan



MS-16D

* Please note that the photo shows typical examples and that they may partly differ from actual items.

Specification table

Impeller diameter of compatible pressure fans	Model	Voltage (V)	Electric current (A)		Starting current (A)		Power consumption (W)		Opening time (secs.)		Closing time (secs.)	
			50Hz	60Hz	50Hz	60Hz	50Hz	60Hz	50Hz	60Hz	50Hz	60Hz
			25cm ~ 40cm	MS(S)-10D~16D	100	0.1 or less		7 or less		8	7	Instant
200	0.07 or less		7 or less		8	7	Instant					
45cm ~ 50cm	MS(S)-18C~20C	100	0.43	0.30	0.45	0.35	18	13	6	5	6	5
45cm ~ 105cm	MS(S)-18D~42D	200	0.81	0.47	0.82	0.52	57	36	5	4	5	4

- * Check the behavior of the wind pressure shutter after it is installed in a flat state.
- * It cannot be used where it is directly exposed to rainwater. Use an outdoor hood.
- * It cannot be fastened together with an outdoor hood or a fireproof hood. If you wish to fasten it together with any such hood, please contact us separately.
- * Ranges of use are as follows:
An ambient temperature of -10 °C to +50 °C and a relative humidity of 90% or less for models compatible with pressure fans where an impeller diameter ranges from 25cm to 40cm;
An ambient temperature of -10 °C to +50 °C and a relative humidity of 90% or less under designations ending with C, and 85% or less under designations ending with D for models compatible with pressure fans where an impeller diameter ranges from 45cm to 60cm;
An ambient temperature of -10 °C to +50 °C and a relative humidity of 85% or less for models compatible with pressure fans where an impeller diameter ranges from 75cm to 105cm.
- * The built-in motor in the drive box of any motor-driven shutter compatible with pressure fans MS(S)-18D, 20D, and 24D where an impeller diameter ranges from 45cm to 60cm, and MS(S)-30D, 36D, and 42D where an impeller diameter ranges from 75cm to 105cm includes a thermal fuse for motor protection. Do not open and close the motor-driven shutter five consecutive times or more or for one continuous minute or longer, or the thermal fuse may blow to protect the built-in motor. If the thermal fuse blows, the motor will no longer operate. In this case, the whole drive box including the built-in motor should be replaced.

Assembly drawing

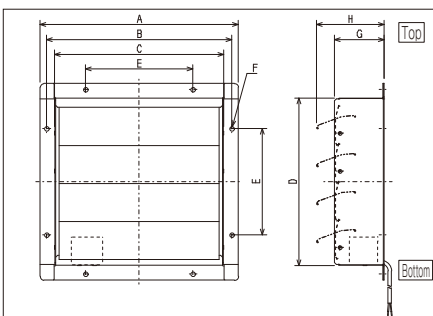

* The shape varies slightly depending on the model.

Dimensions

(Unit:mm)

Impeller diameter of compatible pressure fans	Model		A	B	C	D	E	F	G	H	Number of blades	Approx. mass (kg)
	Steel Plate	Stainless Steel										
25cm	MS-10D	MSS-10D	327	298	271	270	165	8×φ7	130	180	3	4
30cm	MS-12D	MSS-12D	378	349	322	321	210	8×φ7	130	190	3	4.5
35cm	MS-14D	MSS-14D	467	434	392	391	250	8×φ12	130	180	4	6
40cm	MS-16D	MSS-16D	518	485	443	442	280	8×φ12	130	190	4	6.5
45cm	MS-18C	MSS-18C	570	540	495	494	320	8×φ12	130	190	5	10
	MS-18D	MSS-18D										10.5
50cm	MS-20C	MSS-20C	659	620	565	564	355	8×φ15	130	190	5	11.5
	MS-20D	MSS-20D										12
60cm	MS-24D	MSS-24D	760	720	666	665	400	8×φ15	130	190	6	14.5
75cm	MS-30D	MSS-30D	955	900	833	831	508	8×φ20	185	245	8	26
90cm	MS-36D	MSS-36D	1110	1040	986	984	610	8×φ20	185	245	10	32
105cm	MS-42D	MSS-42D	1262	1207	1136	1134	656	8×φ20	185	245	11	37

Example of Use of Operation Circuit

* Precautions
Please note the following.

Impeller diameter of compatible pressure fans	Precautions
25cm~105cm	<ul style="list-style-type: none"> ● Make sure that the power supply has the voltage specified on the rating plate. ● If more than one pressure fan is operated, give consideration to the power supply capacity and other factors.
45cm~105cm	<ul style="list-style-type: none"> ● While the motor-driven shutter is opening or closing, keep it powered on and never power it off. ● The built-in motor in the drive box of any motor-driven shutter compatible with pressure fans MS(S)-18D, 20D, and 24D where an impeller diameter ranges from 45cm to 60cm, and MS(S)-30D, 36D, and 42D where an impeller diameter ranges from 75cm to 105cm includes a thermal fuse for motor protection. Do not open and close the motor-driven shutter five consecutive times or more or for one continuous minute or longer, or the thermal fuse may blow to protect the built-in motor. If the thermal fuse blows, the motor will no longer operate. In this case, the whole drive box including the built-in motor should be replaced. ● If the motor-driven shutter is powered off during the opening or closing operation, the motor-driven shutter will be stopped in a half-open state. To resume its operation, power it on again.
75cm~105cm	<ul style="list-style-type: none"> ● Do not operate the switch during the opening or closing operation. The motor-driven shutter is structured not to move on to the next operation unless the opening or closing operation is finished. If the switch is operated during the opening or closing operation, the shutter will be stopped in a half-open state. To restore its status, perform the switch operation again. ● Make sure that the pressure fan does not start operation until the motor-driven shutter becomes fully open.

* Examples of operation circuits for parallel operation of the motor-driven shutter and the pressure fan

Circuits applicable to pressure fans where an impeller diameter ranges from 25cm to 40cm

MS(S)-10D~16D
Single-phase 100V and 200V

MS(S)-10D~16D
Three-phase 200V

● When the power supply is applied, the motor-driven shutter is in opening operation or in an open state. When the power is off, it is in closing operation or in a closed state.

Circuits applicable to pressure fans where an impeller diameter ranges from 45cm to 60cm

MS(S)-18C/D~20C/D
Single-phase 100V and 200V

MS(S)-18D~24D
Three-phase 200V

● These examples of circuits are for motor-driven shutters with built-in relays.

Circuits applicable to pressure fans where an impeller diameter ranges from 75cm to 105cm

MS(S)-30D~42D
Three-phase 200V

T1: 5 secs. T2: 10 secs.

Steel Plate Stainless Steel

Outdoor Hoods

Blocking intrusion of not only wind and rain but insects and dust as well by attaching an anti-insect or anti-bird net



OFS-12N

* Please note that the photo shows typical examples and that they may partly differ from actual items.

To place an order for an outdoor hood with an anti-insect net, please add "I" at the end of the model code. For an outdoor hood with an anti-bird net, please add "B" at the end of the model code.

Notes:

- * Install at a height or in a place where the anti-insect or anti-bird net can be maintained from outdoors.
- * If you wish to install the hood at a height or in a place where there may be strong outdoor wind, please contact us.
- * Perform regular inspection of the anti-insect or anti-bird net. Perform regular inspection and regular cleaning of the net to keep it unclogged from dust or the like.
- * Although the hood is made of a SUS304 stainless steel plate, which is highly resistant to rust, it is likely to rust in a salty or corrosive environment, such as a place with any strong acid, alkaline or corrosive substance constantly in a wet state or a place exposed to any such substance. We also offer a model with acid- and salt-resistant coating and a model coated with fluorocarbon resin (produced upon order) so that you may use it in an environment as mentioned above.
- * For outdoor hoods with a motor-driven shutter (built-in), please contact us.

Assembly drawing

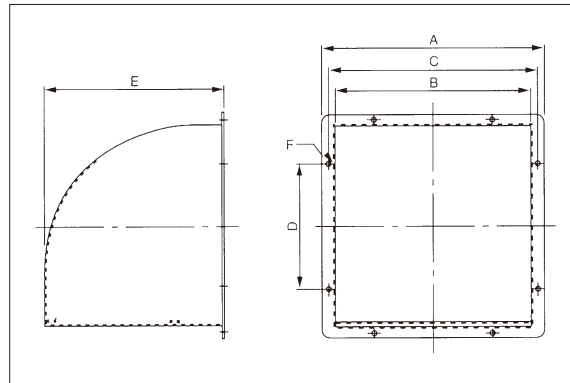

* The shape varies slightly depending on the model.

Dimensions

(Unit:mm)

Impeller diameter of compatible pressure fans	Model				A	B	C	D	E	F	Plate thickness	
	Steel plate		SUS								Steel plate	SUS
	Without net	With net	Without net	With net								
20cm	OF-8	OF-8N	OFS-8	OFS-8N	275	226	246	162	220	8×φ7	1.2	0.8
25cm	OF-10	OF-10N	OFS-10	OFS-10N	327	278	298	165	300	8×φ7	1.2	0.8
30cm	OF-12	OF-12N	OFS-12	OFS-12N	378	329	349	210	340	8×φ7	1.2	0.8
35cm	OF-14	OF-14N	OFS-14	OFS-14N	464	404	434	250	390	8×φ12	1.2	0.8
40cm	OF-16	OF-16N	OFS-16	OFS-16N	515	455	485	280	410	8×φ12	1.2	0.8
45cm	OF-18	OF-18N	OFS-18	OFS-18N	570	510	540	320	440	8×φ12	1.2	1.0
50cm	OF-20	OF-20N	OFS-20	OFS-20N	659	580	620	355	490	8×φ15	1.6	1.0
60cm	OF-24	OF-24N	OFS-24	OFS-24N	759	680	720	400	590	8×φ15	1.6	1.0
75cm	OF-30	OF-30N	OFS-30	OFS-30N	955	845	900	508	765	8×φ20	1.6	1.5
90cm	OF-36	OF-36N	OFS-36	OFS-36N	1110	995	1040	610	900	8×φ20	1.6	1.5
105cm	OF-42	OF-42N	OFS-42	OFS-42N	1262	1145	1207	656	1000	8×φ20	1.6	1.5
120cm	OF-48	OF-48N	OFS-48	OFS-48N	1475	1365	1425	800	1180	8×φ20	1.6	1.5

Stainless Steel

Fireproof Hoods

Incorporating a fire damper to prevent spread of fire



FDS-12N

* Please note that the photo shows typical examples and that they may partly differ from actual items.

To place an order for an outdoor hood with an anti-insect net, please add "I" at the end of the model code. For an outdoor hood with an anti-bird net, please add "B" at the end of the model code.

It cannot be fastened together with a motor-driven shutter or a wind pressure shutter.

Notes:

- * Install at a height or in a place where the anti-insect or anti-bird net can be maintained from outdoors.
- * If you wish to install the hood at a height or in a place where there may be strong outdoor wind, please contact us.
- * Perform regular inspection of the anti-insect or anti-bird net and the thermal fuse. Perform regular inspection and regular cleaning of the net to keep it unclogged from dust or the like.
- * Although the hood is made of a SUS304 stainless steel plate, which is highly resistant to rust, it is likely to rust in a salty or corrosive environment, such as a place with any strong acid, alkaline or corrosive substance constantly in a wet state or a place exposed to any such substance. We also offer a model with acid- and salt-resistant coating and a model coated with fluorocarbon resin (produced upon order) so that you may use it in an environment as mentioned above.

Assembly drawing

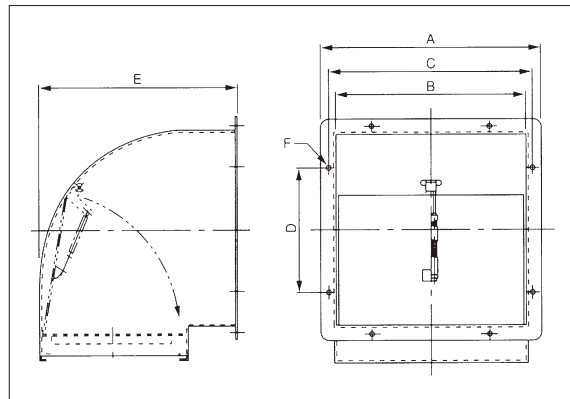

- Japan Testing Center for Construction Materials Test Results Numbers
Thermal fuse performance test at 72 °C: No. 60570
Thermal fuse performance test at 120 °C: No. 60624 (supplementary test)
Smoke leak test: No. 59766

* The shape varies slightly depending on the model.

Dimensions

(Unit:mm)

Impeller diameter of compatible pressure fans	Model		A	B	C	D	E	F	Plate thickness
	Without net	With net							
	30cm	FDS-12							
35cm	FDS-14	FDS-14N	464	404	434	250	400	8×φ12	1.5
40cm	FDS-16	FDS-16N	515	455	485	280	420	8×φ12	1.5
45cm	FDS-18	FDS-18N	570	510	540	320	450	8×φ12	1.5
50cm	FDS-20	FDS-20N	659	580	620	355	505	8×φ15	1.5
60cm	FDS-24	FDS-24N	759	680	720	400	615	8×φ15	1.5
75cm	FDS-30	FDS-30N	995	845	900	508	780	8×φ20	1.5
90cm	FDS-36	FDS-36N	1110	955	1040	610	885	8×φ20	1.5
105cm	FDS-42	FDS-42N	1262	1145	1207	656	925	8×φ20	1.5

Stainless Steel

Intake Outdoor Hoods (with rainwater gutter)

Blocking incoming rainwater and intrusion of insects and dust



Notes:

- * Install at a height or in a place where the anti-insect or anti-bird net can be maintained from outdoors.
- * If you wish to install the hood at a height or in a place where there may be strong outdoor wind, please contact us.
- * Perform regular inspection and regular cleaning of the anti-insect or anti-bird net to keep it unclogged from dust or the like.
- * Although the hood is made of a SUS304 stainless steel plate, which is highly resistant to rust, it is likely to rust in a salty or corrosive environment, such as a place with any strong acid, alkaline or corrosive substance constantly in a wet state or a place exposed to any such substance. We also offer a model with acid- and salt-resistant coating and a model coated with fluorocarbon resin (produced upon order) so that you may use it in an environment as mentioned above.
- * Rainwater may intrude indoors depending on the place or state of installation or on weather conditions.
- * For outdoor hoods with a motor-driven shutter (built-in), please contact us.

* Please note that the photo shows typical examples and that they may partly differ from actual items.

Assembly drawing

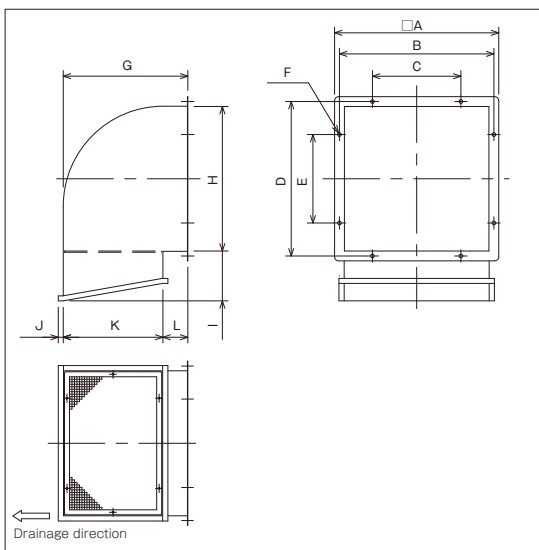

* The shape varies slightly depending on the model.

Dimensions

(Unit:mm)

Impeller diameter of compatible pressure fans	Model		A	B	C	D	E	F	G	H	I	J	K	L	Plate thickness
	With anti-insect net	With anti-bird net													
20cm	OFS-8ANI	OFS-8ANB	275	246	162	246	162	8×φ7	230	226	104	12	175	54	0.8
25cm	OFS-10ANI	OFS-10ANB	327	298	165	298	165	8×φ7	310	278	110	12	230	80	0.8
30cm	OFS-12ANI	OFS-12ANB	378	349	210	349	210	8×φ7	350	329	120	17	260	90	0.8
35cm	OFS-14ANI	OFS-14ANB	464	434	250	434	250	8×φ12	400	404	140	17	310	90	0.8
40cm	OFS-16ANI	OFS-16ANB	515	485	280	485	280	8×φ12	420	455	153	17	320	100	0.8
45cm	OFS-18ANI	OFS-18ANB	570	540	320	540	320	8×φ12	450	510	200	17	350	100	1.0
50cm	OFS-20ANI	OFS-20ANB	659	620	355	620	355	8×φ15	500	580	200	23	400	100	1.0
60cm	OFS-24ANI	OFS-24ANB	759	720	400	720	400	8×φ15	600	680	204	23	500	100	1.0
75cm	OFS-30ANI	OFS-30ANB	955	900	508	900	508	8×φ20	775	845	303	22	655	120	1.5
90cm	OFS-36ANI	OFS-36ANB	1110	1040	610	1040	610	8×φ20	910	995	302	22	760	150	1.5
105cm	OFS-42ANI	OFS-42ANB	1262	1207	656	1207	656	8×φ20	1010	1145	304	22	800	210	1.5
120cm	OFS-48ANI	OFS-48ANB	1475	1425	800	1425	800	8×φ20	1190	1365	300	20	990	200	1.5

Iron

Stainless Steel

Guard Nets

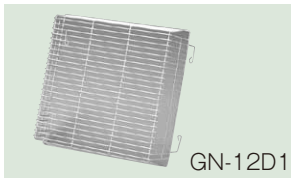

GN-12D1

Guard nets prevent accidents of contacting the rotating part of the pressure fan. As they are designed exclusively for specific models of pressure fans, please choose the model matched with the fan model. Make sure to install a guard net if the pressure fan is installed at a height of 1.8 meters or less.

* Please note that the photo shows typical examples and that they may partly differ from actual items.

Standard Net

Assembly drawing

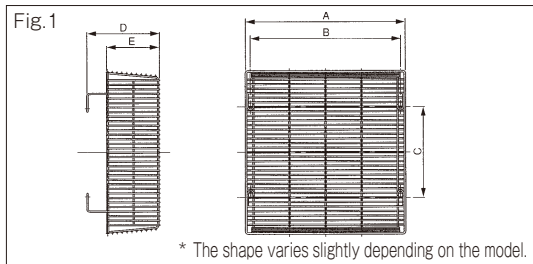

* The shape varies slightly depending on the model.

Materials: Iron wire and stainless steel wire
Surface treatment : PE coating N7 for iron wire
; No treatment for stainless steel wire

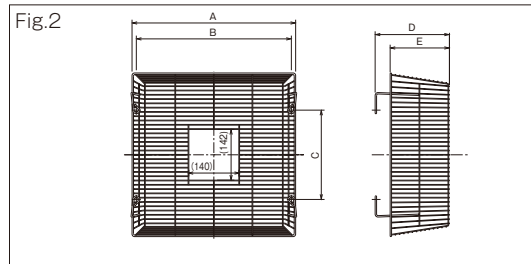

Materials: Iron wire
Surface treatment: PE coating N7

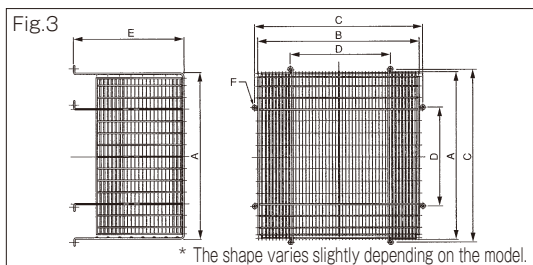

* The shape varies slightly depending on the model.

Materials: Iron wire and stainless steel wire
Surface treatment : PE coating N7 for iron wire
; No treatment for stainless steel wire

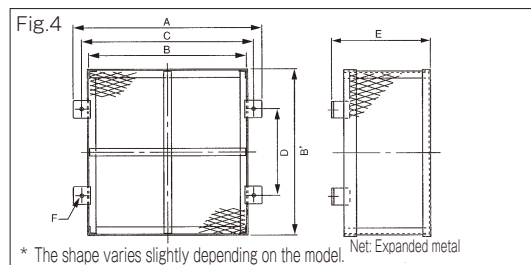

* The shape varies slightly depending on the model. Net: Expanded metal

Dimensions

(Unit:mm)

Materials	Impeller diameter of compatible pressure fans	Fig.	Model	A	B	B'	C	D	E	F
Iron	20cm	1	GN-8D1	264	246	—	162	170	119	—
	25cm	1	GN-10D1	316	298	—	165	170	119	—
		4	GN-10	327	284	310	298	165	245	4×φ7
	30cm	1	GN-12D1	372	349	—	210	175	119	—
		4	GN-12	378	335	360	349	210	265	4×φ7
	35cm	1	GN-14G	458	434	—	250	210	166	—
		2	GN-14G1	458	434	—	250	210	166	—
	40cm	1	GN-16G	509	485	—	280	225	176	—
		2	GN-16G1	509	485	—	280	225	176	—
	45cm	3	GN-18A-3	520	520	—	540	320	420	8×φ12
	50cm	3	GN-20A-3	592	592	—	620	355	425	8×φ15
	60cm	3	GN-24A-3	698	698	—	720	400	455	8×φ15
75cm	4	GN-30S	951	870	870	900	508	470	4×φ20	
90cm	4	GN-36S	1090	1028	1028	1040	610	450	4×φ20	
105cm	4	GN-42SG	1257	1183	1183	1207	656	570	4×φ20	
120cm	4	GN-48	1372	1532	1532	1425	800	550	4×φ20	
Stainless Steel	25cm	1	GNS-10D1	316	298	—	165	170	119	—
		4	GNS-10	327	284	310	298	165	245	4×φ9
	30cm	1	GNS-12D1	372	349	—	210	175	119	—
		4	GNS-12	378	335	360	349	210	300	4×φ7
	35cm	1	GNS-14G	458	434	—	250	210	166	—
	40cm	1	GNS-16G	509	485	—	280	225	176	—
	45cm	4	GNS-18	570	518	550	540	320	400	4×φ12
	50cm	3	GNS-20A	592	592	—	620	355	425	8×φ12
	60cm	3	GNS-24A	698	698	—	720	400	455	8×φ12
	75cm	4	GNS-30	951	870	890	900	508	470	4×φ20
	90cm	4	GNS-36	1090	1028	1060	1040	610	450	4×φ20
	105cm	4	GNS-42SG	1257	1183	1183	1207	656	570	4×φ20

* For applicable models, refer to compatibility tables and dimensional outline drawings.

* The GN-14G1 and the GN-16G1 each have a bypass hole for the motor.

● **Explosion-Proof Net (E Series)**

■ **Assembly drawing**

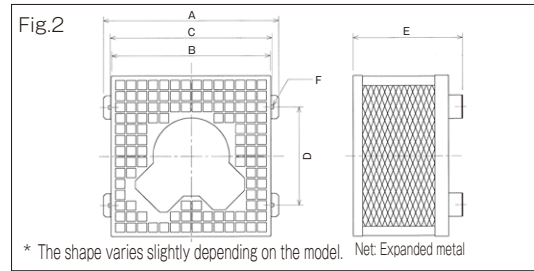
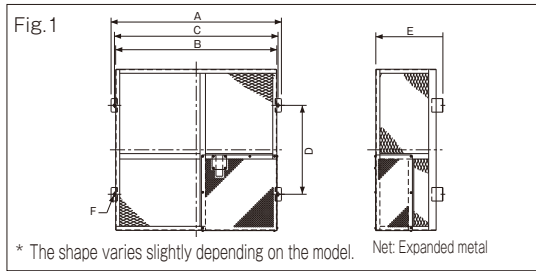

■ **Dimensions**

(Unit:mm)

Impeller diameter of compatible pressure fans	Fig.	Model	A	B	C	D	E	F
20cm	2	EGN-8	270	242	246	162	210	4×φ7
25cm	2	EGN-10	327	291	298	165	211	4×φ9
30cm	2	EGN-12	378	342	349	210	236	4×φ9
35cm	1	EGN-14	467	410	434	250	365	4×φ12
40cm	1	EGN-16	518	461	485	280	365	4×φ12
45cm	1	EGN-18	570	513	540	320	430	4×φ12
50cm	1	EGN-20	659	589	620	355	445	4×φ15
60cm	1	EGN-24	760	699	720	400	480	4×φ15
75cm	1	EGN-30	951	870	900	508	505	4×φ20
90cm	1	EGN-36	1090	1028	1040	610	480	4×φ20
105cm	1	EGN-42	1257	1183	1207	656	495	4×φ20
120cm	1	EGN-48	1381	1525	1425	800	600	4×φ20

* The EGN-12 is different in the shape of the bypass hole for the motor between single-phase power supply and three-phase power supply models.

● **Front Face Net (F Series)**

■ **Assembly drawing**

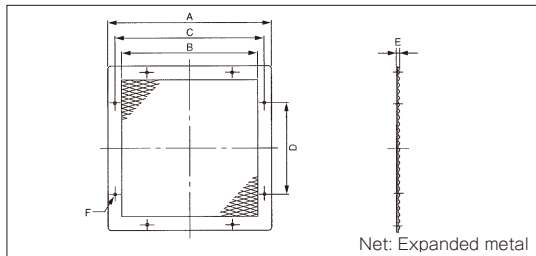

■ **Dimensions**

(Unit:mm)

Impeller diameter of compatible pressure fans	Model	A	B	C	D	E	F
20cm	FGN-8	274	224	246	162	7	8×φ7
25cm	FGN-10	325	275	298	165	7	8×φ7
30cm	FGN-12	376	326	349	210	7	8×φ7
35cm	FGN-14	465	389	434	250	8	8×φ12
40cm	FGN-16	516	440	485	280	8	8×φ12
45cm	FGN-18	568	492	540	320	8	8×φ12
50cm	FGN-20	658	582	620	355	8	8×φ15
60cm	FGN-24	758	682	720	400	8	8×φ15
75cm	FGN-30	955	825	900	508	10	8×φ20
90cm	FGN-36	1110	980	1040	610	10	8×φ20
105cm	FGN-42	1262	1132	1207	656	10	8×φ20
120cm	FGN-48	1475	1345	1425	800	10	8×φ20

Filter Unit

Designed exclusively for pressure fans to guarantee smooth installation and easy maintenance



3FU-12A

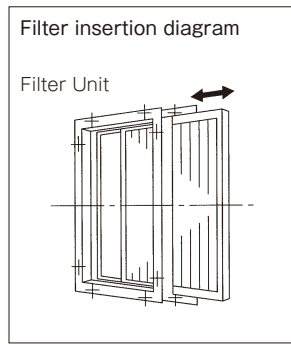

* Please note that the photo shows typical examples and that they may partly differ from actual items.

Selection Diagrams

The diagram represents initial pressure loss characteristics.

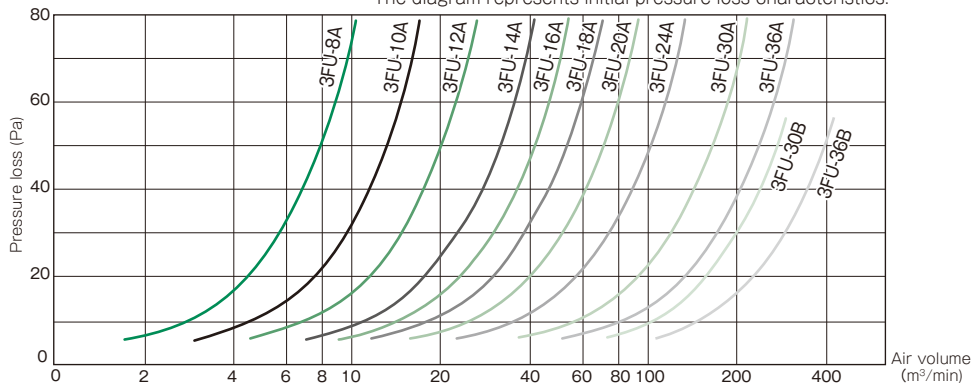

- Trapping efficiency 3FS-8~36 Initial dust collection efficiency 64% (at a wind speed of 2.5m/s)
- 3FP-30,36 Initial dust collection efficiency 28% (at a wind speed of 1.5m/s)

Assembly drawing

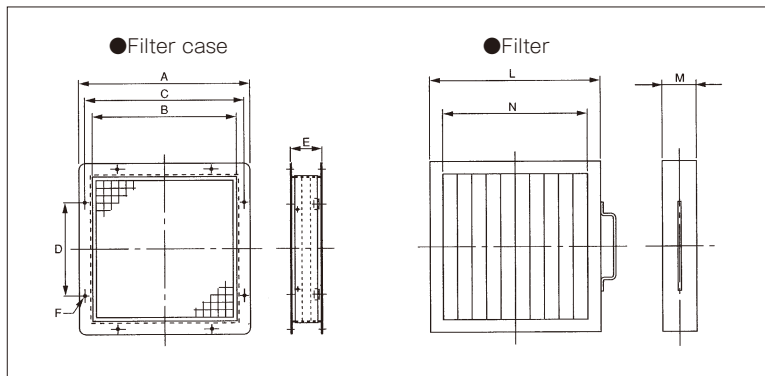

Dimensions

(Unit:mm)

Filter unit	Impeller diameter of compatible pressure fans	Filter case						Filter				
		Model	A	B	C	D	E	F	Model	L	M	N
3FU-8A	20cm	FC-8	276	216	246	162	150	2×8×φ7	3FS-8	210	50	170
3FU-10A	25cm	FC-10	327	267	298	165	150	2×8×φ7	3FS-10	260	50	220
3FU-12A	30cm	FC-12	378	318	349	210	150	2×8×φ7	3FS-12	313	50	273
3FU-14A	35cm	FC-14	467	387	434	250	150	2×8×φ12	3FS-14	382	50	342
3FU-16A	40cm	FC-16	518	438	485	280	150	2×8×φ12	3FS-16	432	50	392
3FU-18A	45cm	FC-18	570	490	540	320	150	2×8×φ12	3FS-18	482	50	442
3FU-20A	50cm	FC-20	659	559	620	355	150	2×8×φ15	3FS-20	552	50	512
3FU-24A	60cm	FC-24	760	660	720	400	150	2×8×φ15	3FS-24	652	50	612
3FU-30A	75cm	FC-30	955	825	900	508	150	2×8×φ20	3FS-30	818	50	778
3FU-30B	75cm								3FP-30			
3FU-36A	90cm	FC-36	1110	980	1040	610	150	2×8×φ20	3FS-36	972	50	932
3FU-36B	90cm								3FP-36			

Precautions for Use

- 1) This table shows the sales launch and termination years of cataloged products as guidelines, as well as replacement products. For your individual product, check the fabrication specifications with the product nameplate, delivery drawing, or the like to determine a replacement product.
- 2) Make sure to check the specifications because some products are fabricated according to specific manufacturers' specifications under the same model codes as standard products.
- 3) The explosion-proof pressure fan series can be replaced as-is after checking the power supply details (single-phase or three-phase, voltage, and frequency) because they are unchanged in specifications.
- 4) Since the S series has several types of centrifugal contacts, check the fabrication specifications of your individual product with the product nameplate, delivery drawing, or the like to see if the existing product can be used.

Sales Launch Year

Old model		1953
New PF	A series	1982
Flat	D series	1986
Powerful	G series	1996
New motor	G series	2006
Low noise	N series	2017

Description of types

(Example) PF - 14 B T 2 G 35cm standard pressure fan, three-phase 200V, G series

⑦ ① ② ③ ④ ⑤ ⑥ ⑧

- ① Model type PF: Standard type (different voltage type)/WP: Outdoor type
- ② Impeller nominal diameter Indicated in inches; For a value in centimeters, multiply the value in inches by 2.5
- ③ Airflow direction B: Exhaust/A: Intake * When facing the front of the impeller, exhaust air flows forward, and intake air flows backward.
- ④ Power supply S: Single-phase/T: Three-phase
- ⑤ Voltage 1: 100 volt class/2: 200 volt class/4: 400 volt class
- ⑥ Series code Ascending alphabetical order
- ⑦ Number of poles None: Standard/Number specified: Multiple-pole type (6: six poles, 8: eight poles)
- ⑧ ID code None, 1, 2...

Old model products are designated as PF-14B.

Model Development Table

Impeller diameter	Type	Number of phases	Voltage	Frequency	Old model		Sales period							Existing model				
					Product model	Assembly drawing	Sales launch year	Sales termination year	1950s	1960s	1970s	1980s	1990s	2000s	2010s	2020s	Product model	Assembly drawing
20cm	Standard Type	1	100		PF-8ASA	PFA-201A	1982	1986									PF-8AS1D	A1984-01
			200		PF-8ASB	PFA-201B PFA-202B	1982	1986									PF-8AS2D	A1984-02
		1	100		PF-8ASD	A209-05 A209-06	1986	2015									PF-8AS1D	A1984-01
			200		PF-8B	D-23759 D-23759	1953	1981									PF-8AS2D	A1984-02
		1	100		PF-8BF	A442-01	1988	2015									PF-8BS1D	A1977-01
			200		PF-8BSB	PFB-201B PFB-202B	1982	1985									PF-8BS2D	A1977-02
		1	100		PF-8BSD	A208-06 A208-07	1986	2015									PF-8BF2	A1995-02
200															PF-8BS1D	A1977-01		
25cm	Standard Type	1	100		PF-10A	D-23572 D-23571	1953	1981									PF-8BS2D	A1977-02
			200		PF-10ASA	PFA-251A PFA-252A	1982	1985									PF-8BS1D	A1977-01
		1	100		PF-10ASB	PFA-251B PFA-252B	1982	1985									PF-8BS2D	A1977-02
			200		PF-10ASD	A211-05 A211-06	1986	2016									PF-8BS1D	A1977-01
		1	100		PF-10AS1D	A1985-01	2015	2025									PF-8BS2D	A1977-02
			200		PF-10AS2D	A1985-02	2015	2025									PF-10AS1N	A2124-01
		1	100		PFS-10ASD	A674-02 A674-03	1990	-									PF-10AS2N	A2124-02
			200		PF-10B	D-23398 D-23398	1953	1981									PF-10AS1N	A2124-01
		1	100		PF-10BSB	PFB-251B PFB-252B	1982	1985									PF-10AS2N	A2124-02
			200		PF-10BSD	A210-06 A210-07	1986	2016									PF-10AS1N	A2124-01
	Outdoor Type	1	100		PF-10BS1D	A1978-01	2015	2025									PF-10AS2N	A2124-02
			200		PF-10BS2D	A1978-02	2015	2025									PF-10AS1N	A2124-01
		1	100		PFS-10BSD	A308-04 A308-08	1988	-									PF-10AS2N	A2124-02
			200		WP-10A	C411-01 C411-05	1953	-									PFS-10ASD	A674-02 A674-03
		1	100		WP-10B	C279-01 C279-05	-	-									PF-10BS1N	A2123-01
			200														PF-10BS2N	A2123-02
		30cm	Standard Type	1	100		PF-12A	D-23622 D-23785	1953	1981								
200					PF-12ASA	PFA-301A PFA-302A	1982	1985									PF-10BS2N	A2123-02
3	200				PF-12ASB	PFA-301B PFA-302B	1982	1985									PF-10BS1N	A2123-01
	200				PF-12ASD	A227-08 A227-09	1986	1995									PF-10BS2N	A2123-02
1	100				PF-12ASG	A999-05 A999-06	1996	2005									PF-10BS1N	A2123-01
	200				PF-12AS1D	A1765-01	2006	2016									PF-10BS2N	A2123-02
1	100				PF-12AS2D	A1765-02	2006	2016									PF-12AS1N	A2073-01
	200																PF-12AS2N	A2073-02

Model Development Table

Pressure Fans

Impeller diameter	Type	Number of phases	Voltage	Frequency	Old model				Sales period								Existing model					
					Product model	Assembly drawing	Sales launch year	Sales termination year	1950s	1960s	1970s	1980s	1990s	2000s	2010s	2020s	Product model	Assembly drawing				
30cm	Standard Type	1	100		PF-12AS1D1	A2003-01	2016	2017										PF-12AS1N	A2073-01			
		1	200		PF-12AS2D1	A2003-02	2016	2017										PF-12AS2N	A2073-02			
		1	100		PFS-12ASD	A638-04	1986	1995										PFS-12AS1N	A2082-01			
		200		A638-05												PFS-12AS2N	A2082-02					
		3	200		PF-12ATB	PFA-303B	1982	1985										PF-12AT2N	A2074-01			
		3	200		PF-12ATD	A228-11	1986	1995											PF-12AT4N	A2074-01		
		400		—													PF-12AT4N	A2074-02				
		3	200		PF-12ATG	A1000-02	1996	2005											PF-12AT2N	A2074-01		
		400		—													PF-12AT4N	A2074-02				
		3	200		PF-12AT2D	A1766-01	2006	2016											PF-12AT2N	A2074-01		
		3	400		PF-12AT4D	A1766-02	2006	2016											PF-12AT4N	A2074-02		
		3	200		PF-12AT2D1	A2004-01	2016	2017											PF-12AT2N	A2074-01		
		3	200		PFS-12ATD	A712-02	1986	2017											PFS-12AT2N	A2083-01		
		400		A712-04														PFS-12AT4N	A2083-02			
		1	100		PF-12B	D-23632	1953	1981											PF-12BS1N	A2071-01		
		200		D-23632														PF-12BS2N	A2071-02			
		3	200			D-23616												PF-12BT2N	A2072-01			
		1	100		PF-12BSB	PFB-301B	1982	1985											PF-12BS1N	A2071-01		
		200		PFB-302B														PF-12BS2N	A2071-02			
		1	100		PF-12BSD	A225-05	1986	1995											PF-12BS1N	A2071-01		
		200		A225-06														PF-12BS2N	A2071-02			
		1	100		PF-12BSS	PFB-301S	1982	1985											PF-12BS1N	A2071-01		
		200		PFB-302S														PF-12BS2N	A2071-02			
		1	100		PF-12BSE	—	1986	1995											PF-12BS1N	A2071-01		
		200		—														PF-12BS2N	A2071-02			
		1	100		PF-12BSG	A992-05	1996	2005											PF-12BS1N	A2071-01		
		200		A992-06														PF-12BS2N	A2071-02			
		1	100		PF-12BS1G	A1763-01	2006	2016											PF-12BS1N	A2071-01		
		1	200		PF-12BS2G	A1763-02	2006	2016											PF-12BS2N	A2071-02		
		1	100		PF-12BS1G1	A1991-01	2016	2017											PF-12BS1N	A2071-01		
		1	200		PF-12BS2G1	A1991-02	2016	2017											PF-12BS2N	A2071-02		
		1	100		PFS-12BSD	A309-03	1988	2017											PFS-12BS1N	A2080-01		
		3	200		PF-12BTB	PFB-303B	1982	1985												A2072-01		
		3	200		PF-12BTD	A226-15	1986	1995												PF-12BT2N		
		200		A993-03																		
		3	400		PF-12BTG	—	1996	2005											PF-12BT4N	A2072-02		
		3	200		PF-12BTS	PFB-303S	1982	1985											PF-12BT2N	A2072-01		
		3	200		PF-12BT2G	A1764-01	2006	2016											PF-12BT2N	A2072-01		
		3	400		PF-12BT4G	A1764-02	2006	2016											PF-12BT4N	A2072-02		
		3	200		PF-12BT2G1	A1992-01	2016	2017											PF-12BT2N	A2072-01		
		3	200		PFS-12BT2D	A1983-02	2016	2017											PFS-12BT2N	A2081-01		
		Outdoor Type		1	100		WP-12A	C254-01	1953	—										WP-12A	C254-01	
				200		C254-04														WP-12A	C254-04	
				1	100		WP-12B	C506-01	1953	—											WP-12B	C506-01
				200		C506-02															WP-12B	C506-02
35cm	Standard Type	1	100		PF-14A	D-23800	1953	1981										PF-14AS1N	A2107-01			
		200		D-23800														PF-14AS2N	A2107-02			
		3	200			D-23684													PF-14AT2N	A2108-01		
		1	100		PF-14ASA	PFA-351A	1982	1985											PF-14AS1N	A2107-01		
		200		PFA-352A															PF-14AS2N	A2107-02		
		1	100		PF-14ASD	A191-05	1986	1995											PF-14AS1N	A2107-01		
		200		A191-06															PF-14AS2N	A2107-02		
		1	100		PF-14ASG	A1030-03	1996	2005											PF-14AS1N	A2107-01		
		200		A1030-04															PF-14AS2N	A2107-02		
		3	200		PF-14ATA	PFB-353A	1982	1985											PF-14AT2N	A2108-01		
		3	200		PF-14ATD	A192-01	1986	1995											PF-14AT2N	A2108-01		
		3	200		PF-14ATG	A1029-02	1996	2005												PF-14AT2N	A2108-01	
		1	100		PF-14AS1D	A1602-01	2006	2018												PF-14AS1N	A2107-01	
		1	200		PF-14AS2D	A1602-02															PF-14AS2N	A2107-02
		3	200		PF-14AT2D	A1603-01															PF-14AT2N	A2108-01
		1	100		PF-14B	D-23851	1953	1981												PF-14BS1N	A2105-01	
		200		D-23851																	PF-14BS2N	A2105-02
		3	200			D-23725																PF-14BT2N
		1	100		PF-14BSA	PFB-351A	1982	1985												PF-14BS1N	A2105-01	
		200		PFB-352A																		PF-14BS2N
		1	100		PF-14BSD	A189-08	1986	1995												PF-14BS1N	A2105-01	
		200		A189-09																		PF-14BS2N
		1	100		PF-14BSG	A1028-04	1996	2005												PF-14BS1N	A2105-01	
		200		A1028-05																		PF-14BS2N
		3	200		PF-14BTA	PFB-353A	1982	1985												PF-14BT2N	A2106-01	
		3	200		PF-14BTD	A190-05	1986	2005												PF-14BT2N	A2106-01	
		3	200		PF-14BTG	A1027-02	1996	2005												PF-14BT2N	A2106-01	
		400		—																		PF-14BT4N
		1	100		PF-14BS1G	A1595-01	2006	2018												PF-14BS1N	A2105-01	
		1	200		PF-14BS2G	A1595-02															PF-14BS2N	A2105-02
3	200		PF-14BT2G	A1596-01															PF-14BT2N	A2106-01		

Impeller diameter	Type	Number of phases	Voltage	Frequency	Old model				Sales period							Existing model	
					Product model	Assembly drawing	Sales launch year	Sales termination year	1950s	1960s	1970s	1980s	1990s	2000s	2010s	2020s	Product model
35cm	Outdoor Type	1	100		WP-14A		1953	1981								WP-14AS1D	
		1	100		WP-14ASA	C422-01	1982	2005								WP-14AS1D	
		200	C422-02	WP-14AS2D													
		3	200		WP-14ATA	C360-01										WP-14AT2D	
		1	100		WP-14B	C-24138	1953	2005								WP-14BS1G	C938-01
		200	C-24138	WP-14BS2G		C938-02											
		3	200		C-24135											WP-14BT2G	C941-01
		1	100		WP-14BSA	C306-01	1982	2005								WP-14BS1G	C938-01
200	C306-02	WP-14BS2G	C938-02														
3	200		WP-14BTA	C307-01										WP-14BT2G	C941-01		
40cm	Standard Type	1	100		PF-16A	D-23625	1953	1981								PF-16AS1D	
		200	D-23625	PF-16AS2D													
		3	200		D-23839										PF-16AT2D		
		1	100		PF-16ASA	PFA-401A	1982	1985								PF-16AS1D	
		200	PFA-402A	PF-16AS2D													
		1	100	50	PF-16ASC	PFA-401C	1982	1985								6PF-16AS1D	
		200	PFA-402C	6PF-16AS2D													
		1	100		PF-16ASD	A195-06	1986	1995								PF-16AS1D	
		200	A195-07	PF-16AS2D													
		1	100		PF-16ASE	A199-05	1986	1995								6PF-16AS1D	
		200	A199-06	6PF-16AS2D													
		1	100		PF-16ASG	A1034-03	1996	2005								PF-16AS1D	
		200	A1034-04	PF-16AS2D													
		1	100		PFS-16ASD	A732-05	1986	2005								PFS-16AS1D	
		200	A732-06	PFS-16AS2D													
		3	200		PF-16ATA	PFA-403A	1982	1985								PF-16AT2D	
		3	200			PFA-403C			6PF-16AT2D								
		3	200		PF-16ATD	A196-06	1986	1995								PF-16AT2D	
		3	200			A200-04			6PF-16AT2D								
		3	200		PF-16ATF	A868-04	1994	2005								PF-16AT2F	A1610-01
		400	A868-05	PF-16AT4F		A1610-12											
		3	200		PF-16ATG	A1033-03	1996	2005								PF-16AT2D	
		3	200			A1037-02			PF-16AT2D								
		3	200		PF-16ATS	PFA-403S	1982	1985								PF-16AT2D	
		3	200														
		3	200		PFS-16ATD	A687-06	1990	2005								PFS-16AT2D	A1657-01
		400	-	PFS-16AT4D		A1657-03											
		1	100		PF-16B	D-23619	1953	1981								PF-16BS1G	
		200	D-23619	PF-16BS2G													
		3	200		D-23620										PF-16BS2G		
		1	100		PF-16BSA	PFB-401A	1982	1985								PF-16BS1G	
		200	PFB-402A	PF-16BS2G													
		1	100		PF-16BSC	PFB-401C	1982	1985								6PF-16BS1G	
		200	PFB-402C	6PF-16BS2G													
		1	100		PF-16BSD	A193-11	1986	1995								PF-16BS1G	
		200	A193-12	PF-16BS2G													
		1	100		PF-16BSE	A197-05	1986	1995								6PF-16BS1G	
		200	A197-06	6PF-16BS2G													
		1	100		PF-16BSG	A1032-04	1996	2005								PF-16BS1G	
		200	A1032-05	PF-16BS2G													
		1	100		PF-16BSH	A1036-03	1996	2005								6PF-16BS1G	
		200	A1036-04	6PF-16BS2G													
		1	100		PF-16BSS	PFB-401S	1982	1985								PF-16BS1G	
		200	PFB-402S	PF-16BS2G													
		1	100		PFS-16BSD	A311-05	1988	2005								PFS-16BS1D	
		200	-	PFS-16BS2D													
		3	200		PF-16BTA	A499-02	1982	1985								PF-16BT2G	
		3	200			A373-01											
		3	200		PF-16BTC	A374-01	1982	1985								6PF-16BT2G	
		3	200			A194-10			PF-16BT2G								
3	200		PF-16BTE	A198-04	1986	1995								6PF-16BT2G			
3	200			A789-10			PF-16BT2F										
3	400		PF-16BTF	A789-20	1992	1995								PF-16BT4F			
3	200			A1031-02			PF-16BT2G										
3	200		PF-16BTG	A1035-02	1996	2005								6PF-16BT2G			
3	200																
3	200		PF-16BTS	PFB-403S	1982	1985								PF-16BT2G			
400	-	PF-16BT4G															
3	200		PFS-16BTD	A307-09	1988	2005								PFS-16BT2D	A1612-01		
Outdoor Type	1	100		WP-16A		1953	1981								WP-16AS1D	C945-01	
	1	100		WP-16ASA	C298-01	1982	2005								WP-16AS1D	C945-01	
200	C298-02	WP-16AS2D	C945-02														

Model Development Table

Pressure Fans

Impeller diameter	Type	Number of phases	Voltage	Frequency	Old model				Sales period							Existing model					
					Product model	Assembly drawing	Sales launch year	Sales termination year	1950s	1960s	1970s	1980s	1990s	2000s	2010s	2020s	Product model	Assembly drawing			
40cm	Outdoor Type	3	200		WP-16ATA	C260-01	1982	2005										WP-16AT2D	C948-01		
		3	200		WP-16ATC	C348-01	1982	2005										6WP-16AT2D			
		1	100		WP-16B		1953	1981	←	→								WP-16BS1G	C939-01		
		1	200		WP-16BSA	C289-01	1982	2005											WP-16BS1G	C939-01	
			100			C289-02															WP-16BS2G
		1	200		WP-16BSC	C477-01	1982	2005											6WP-16BS1G	C940-01	
			200			C477-02															6WP-16BS2G
		3	200		WP-16BTA	C265-01	1982	2005											WP-16BT2G	C942-01	
3	200		WP-16BTC	C255-01	1982	2005											6WP-16BT2G	C943-01			
45cm	Standard Type	1	100		PF-18A	D-23711	1953	1981	←	→								PF-18AS1A	A1632-01		
			200			D-23711														PF-18AS2A	A1632-02
		3	200			D-23715												PF-18AT2A	A1633-01		
		1	100		PF-18ASA	PFA-451A	1982	2005											PF-18AS1A	A1632-01	
			200			PFA-452A															PF-18AS2A
		3	200		PF-18ATA	PFA-453A	1982	2005											PF-18AT2A	A1633-01	
			400																		PF-18AT4A
		1	100		PF-18B	D-23709	1953	1981	←	→									PF-18BS1A		
	200			D-23709																	PF-18BS2A
	3	200			D-23702				←	→								PF-18BT2A			
	1	100		PF-18BSA	PFB-451A	1982	2005												PF-18BS1A		
		200			PFB-452A																PF-18BS2A
	3	200		PF-18BTA	PFB-453A	1982	2005											PF-18BT2A			
	Outdoor Type	3	200		WP-18A		1953	1981	←	→									WP-18AT2A	C981-01	
		3	200		WP-18ATA	C475-01	1982	2005											WP-18AT2A	C981-01	
		3	200		WP-18B		1953	1981	←	→									WP-18BT2A	C978-01	
1		100		WP-18BSA	C249-01	1982	2005												WP-18BA1A	C978-01	
		200			C249-02																WP-18BS2A
3		200		WP-18BTA	C282-01	1982	2005											WP-18BT2A	C978-01		
50cm		Standard Type	1	100		PF-20A	D-23933	1953	1981	←	→								PF-20AS1A	A1660-01	
				200			D-23933														
	3		200			D-23688												PF-20AT2A			
	1		100		PF-20ASA	PFA-501A	1982	2005												PF-20AS1A	A1660-01
			200			PFA-502A															
	1		200		PF-20ASS	A1678-02	2007	2007											PF-20AS2A	A1660-02	
	3		200		PF-20ATA	A1332-01	1982	2005												PF-20AT2A	
			400			—															
	3	200		PF-20ATS	A676-01	1990	2005											PF-20AT2A			
	1	100		PF-20B	D-23909	1953	1981	←	→										PF-20BS1G		
		200			D-23909																
	3	200			D-23694				←	→									PF-20BT2G		
	1	100		PF-20BSA	PFB-501A	1982	2005													PF-20BS1G	
		200			PFB-502A																
	3	200		PF-20BTA	A428-02	1982	2005													PF-20BT2G	
		400			A428-03																
3	200		PF-20BTS	A518-01	1988	2005													PF-20BT2G		
	400	50		A518-04																	PF-20BT4G
		60		A518-07																	
Outdoor Type	1	100		WP-20A		1953	1981	←	→									WP-20AS1A	C1006-01		
	1	100		WP-20ASA	C383-01	1982	2005												WP-20AS1A	C1006-01	
		200			C383-02																WP-20AS2A
	3	200		WP-20ATA	C275-01	1982	2005											WP-20AT2A	C1007-01		
	3	200		WP-20B	PFB-301S-01	1953	1981	←	→									WP-20BT2G	C944-01		
	1	100		WP-20BSA	C235-01	1982	2005													WP-20BS1G	C995-01
		200			C235-02																
	3	200		WP-20BTA	C428-02	1982	2005												WP-20BT2G	C944-01	
3	200	50	8WP-20BTA	C535-08	1995	2005													WP-20BT2G	C944-01	
	60			C535-07																	
Standard Type	3	200		PF-24A	D-23588	1953	1981	←	→										PF-24AT2G	A1674-01	
	3	200		PF-24ATA	A575-01	1982	2005														
	3	200		PF-24ATB	PFA-603B	1982	2005														
	3	200	50	8PF-24A	A322-01	1988	2005													8PF-24AT2G	A1673-01
		60			A322-02																
	3	400	50		A322-12																
		60		—																	8PF-24AT4G
	3	200	50	PF-24B	A519-01	1953	1981	←	→											PF-24BT2G	
60			A519-03																		
3	200		PF-24BTA	A344-01	1982	2005															
400		A428-02																			

Impeller diameter	Type	Number of phases	Voltage	Frequency	Old model				Sales period							Existing model	
					Product model	Assembly drawing	Sales launch year	Sales termination year	1950s	1960s	1970s	1980s	1990s	2000s	2010s	2020s	Product model
60cm	Standard Type	3	200	50	PF-24BTB	A334-02	1982	2005	←→							PF-24BT2G	
			400			A334-03											
		3	200	60	8PF-24B	A343-01	1988	2005	←→							PF-24BT4G	
			200			A343-02											
	Outdoor Type	3	200	50	WP-24A	C294-01	1953	1981	←→							WP-24AT2G	C1010-01
						60			C294-02								
		3	200	60	8WP-24A	C295-01	1989	2005	←→							8WP-24AT2G	C1011-01
						50			C295-02								
		3	200	50	WP-24ATA	WPA-603A	1982	2005	←→							WP-24AT2G	C1010-01
						60			WPA-603B								
		3	200	50	WP-24ATB	C237-01	1953	1981	←→							WP-24BT2G	C1008-01
						60			C237-02								
3	200	60	8WP-24B	C281-03	1988	2005	←→							8WP-24BT2G	C1011-01		
				50			C281-04										
3	200	50	WP-24BTA	C323-01	1982	2005	←→							WP-24BT2G	C1008-01		
				60			8WPB-603A										
3	200	50	WP-24BTB	WPB-603B	1982	2005	←→							WP-24BT2G	C1008-01		
				60													
75cm	Standard Type	3	200	50	PF-30A	A398-01	1953	2005	←→							PF-30AT2	A1689-01
			60			A398-02											
		3	200	60	8PF-30A	A381-01	1988	2005	←→							8PF-30AT2	A1697-01
						50			A381-02								
	3	200	50	PF-30B	A454-01	1953	2005	←→							PF-30BT2		
					60			A454-02									
	3	200	60	8PF-30B	A400-01	1988	2005	←→							8PF-30BT2	A1696-02	
					50			A400-02									
	Outdoor Type	3	200	50	WP-30A	C233-01	1953	2005	←→							WP-30AT2	C1043-01
						60			C233-02								
		3	200	60	8WP-30A	C287-13	1988	2005	←→							WP-30BT2	C1040-01
						50			C262-01								
3	200	60	WP-30B	C262-02	1953	2005	←→							WP-30BT2	C1040-02		
				50													
3	200	50	8WP-30B	C287-13	1988	2005	←→							WP-30BT2G			
				60													
90cm	Standard Type	3	200	50	PF-36A	A521-01	1953	2005	←→							PF-36AT2	A1690-01
			60			A521-02											
		3	200	60	8PF-36A	A392-01	1988	2005	←→							8PF-36AT2	A1699-01
						50			A392-02								
	3	200	60	PF-36B	A345-01	1953	2005	←→							PF-36BT2G		
					50			A345-02									
	3	200	60	8PF-36B	A348-01	1988	2005	←→							8PF-36BT2	A1698-01	
					50			A348-02									
	Outdoor Type	3	200	50	WP-36A	C363-01	1953	2005	←→							WP-36AT2	C1044-01
						60			C363-02								
		3	200	60	8WP-36A		1953	2005	←→							WP-36AT2	C1044-02
						50											
3	200	60	WP-36B	C234-01	1953	2005	←→							WP-36BT2G			
				50			C234-02										
3	200	60	8WP-36B	C-WP90-18C-1	1988	2005	←→							WP-36BT2G			
				50													
105cm	Standard Type	3	200	50	PF-42A	A508-01	1953	2005	←→							PF-42AT2	A1691-01
			60			A508-03											
		400	A508-04														
	Outdoor Type	3	200	50	PF-42B	A328-01	1953	2005	←→							PF-42BT2G	
						60			A328-02								
		3	200	60	WP-42A	C248-01	1953	2005	←→							WP-42AT2	C1045-01
50	C248-02																
3	200	60	WP-42B	C240-01	1953	2005	←→							WP-42BT2G			
				50			C240-02										
120cm	Standard Type	3	200	50	PF-48A	A406-03	1953	-	←→							PF-48A	A406-03
			60			A406-04											
		3	200	50	PF-48B	A458-03	1953	-	←→							PF-48B	A458-03
	60	A458-04															
	Outdoor Type	3	200	50	WP-48A	C256-01	1953	-	←→							WP-48A	C256-01
						60			C256-02								
3		200	60	WP-48B	C230-01	1953	-	←→							WP-48B	C230-01	
	50				C230-02												

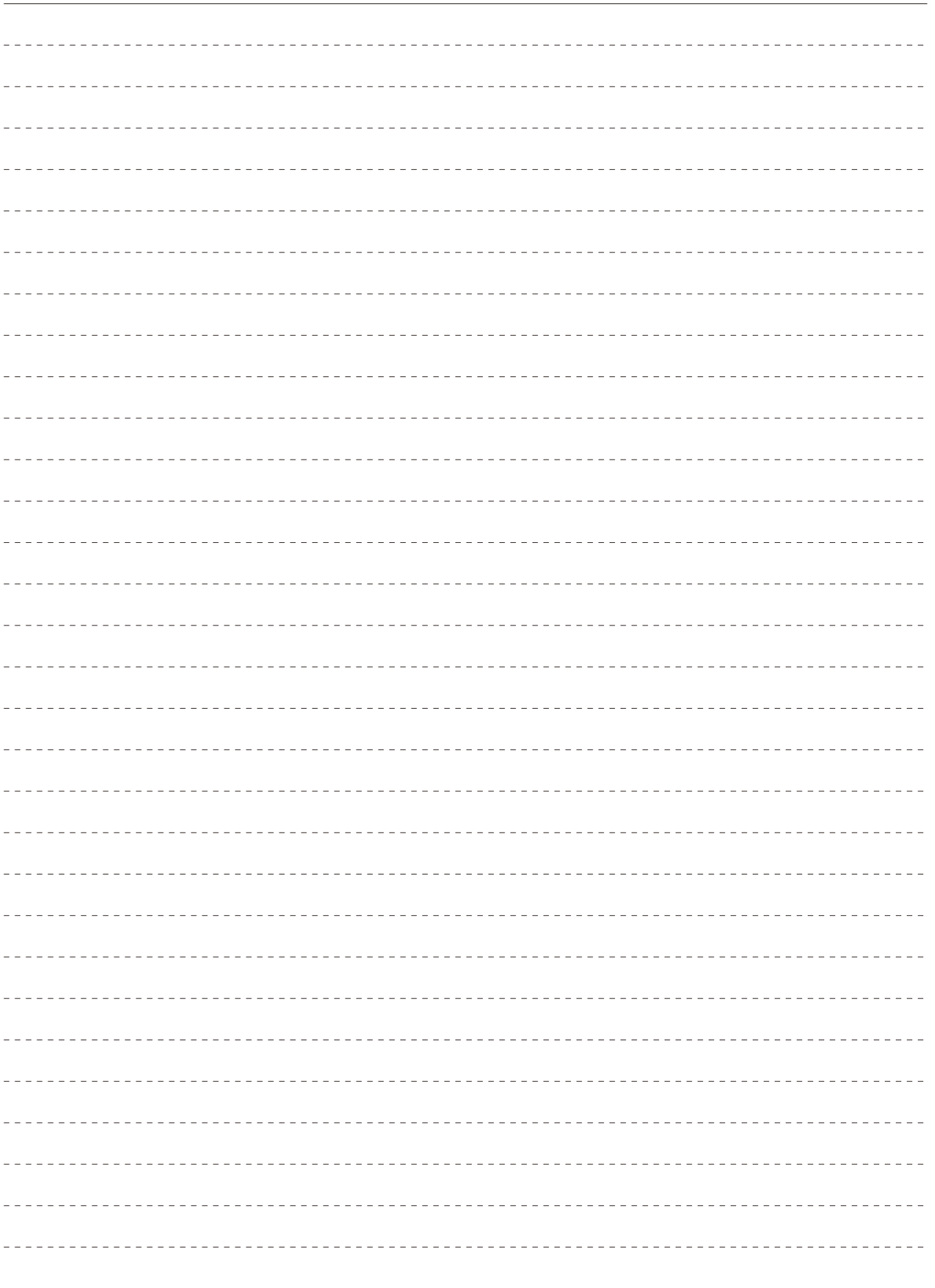

TERAL

TERAL INC.

Head Office 230, Moriwake, Miyuki-cyo, Fukuyama-city, Hiroshima, 720-0003, Japan
Tel.+81-84-955-1111 Fax.+81-84-955-5777
www.teral.net

Teral Asia Limited

Room 1001,10/F, Olympia Plaza, 255 King's Road, North Point, Hong Kong
Tel.+852-2571-0935 Fax.+852-2571-0619

TERAL THAI CO.,LTD.

150 Moo 16 Udomsorayuth Rd., T.Bangkrasan, A.Bangpa-In, Ayutthaya 13160 Thailand
Tel.+66-3535-2148-9 Fax.+66-3535-2150

TERAL TRADING & SERVICE CO.,LTD.

150 Moo 16 Udomsorayuth Rd., T.Bangkrasan, A.Bangpa-In, Ayutthaya 13160 Thailand
Tel.+66-3535-2145-7 Fax.+66-3535-8549

PT.Teral Indonesia Pumps and Fans

Sinpasa Commercial Blok SB No 001
Jl. Boulevar Selatan Summarecon Bekasi
RT.003/RW.005, Kel. Marga Mulya, Kec. Bekasi Utara, Kota Bekasi, Jawa Barat 17142
TEL.+62-21-8949-4116

Teral Vietnam Limited Liability Company

9th Floor, LADECO Building, No.266 Doi Can Street, Ngoc Ha Ward, Hanoi City, Vietnam
Tel.+84-24-393-52-790 Fax.+84-24-393-52-289

Teral General Machine (Shanghai) Co.,Ltd.

No.285, Yuan Qu Road(N), Bei Qiao, Min Hang District, Shanghai 201109, China
Tel.+86-21-6490-9128 Fax.+86-21-6490-9126

Teral Middle East F.Z.C.

1806-002, 18th floor, BB1, Mazaya Business Avenue, JLT, Dubai, UAE. PO Box 414781
Tel.+971-4369 9039

Teral Pumps & Fans North America Ltd.

Suite # 197, 800-15355 24 Ave Surrey, B.C., CANADA V4A 2H9
Tel.+1-604-839-1008

Teral Philippines Inc.

Roof Deck 3, Vernida 1 Building, 120 Amorsolo St., Legaspi Village, Makati City
Tel.+63 2 7717-9314