

Deep well submersible pumps

MSU

TERAL

50Hz



TERAL INC.



* Please note that the paint color, etc. of the actual unit may partially differ from the photo.

Applications

- Pumping of groundwater
- Agricultural irrigation
- Air conditioning
- Industrial water
- Water sprinkling
- Simple waterworks
- Melting of snow
- Pig farming and other livestock breeding

Features

Wide choice of variation

- MSUS model (made of stainless steel)** Well diameter 100mm - 200mm or more, pump bore 25mm - 100mm
- MSU model (made of cast iron)** Well diameter 75mm - 400mm or more, pump bore 25mm - 250mm
- MSUH model (for hot spring (simple hot spring))** Well diameter 100mm - 150mm or more, pump bore 25mm - 80mm

Hygienic (MSUS model)

Hygienic with high resistance to rust and corrosion as the wetted parts of the pumps are made of stainless steel (impeller and casing), and the motors are also made of stainless steel.

Enhanced life

Robust structure with bearings installed at both ends of the pump shaft, and adoption of double structure to prevent the entry of sand into the motors. (Applicable to 6-inch (well diameter 150mm) with M6 motor or higher.)

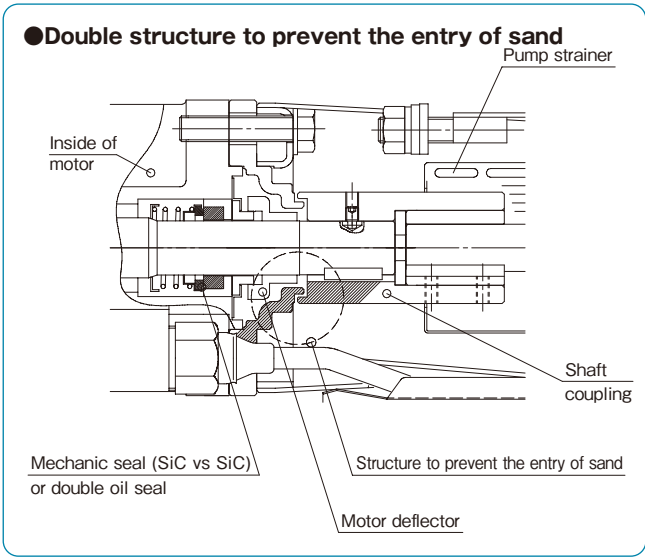

Features of deep well submersible pumps made of stainless steel, equipped with stainless steel impellers **6-inch 8-inch**

Compact

Due to the optimum design, the maximum diameter of 8-inch (well diameter 200mm) pumps is greatly reduced.

Pump bore 80mm, maximum diameter 183mm (conventionally 193mm)

*** Additionally compact as the maximum diameter is 167mm for 18.5kW or less.**

Efficient

High efficiency is realized by optimally designed three-dimensional impeller and three-dimensional guide vane.

The maximum pump efficiency is increased by approximately 3% compared with conventional models.

Enhanced life

- Robust structure with bearings installed at both ends of the pump shaft. ※1 ※2
- Adoption of SiC pump bearings high in wear resistance. ※1
- Adoption of double structure to prevent the entry of sand into motors as in the case of conventional models.

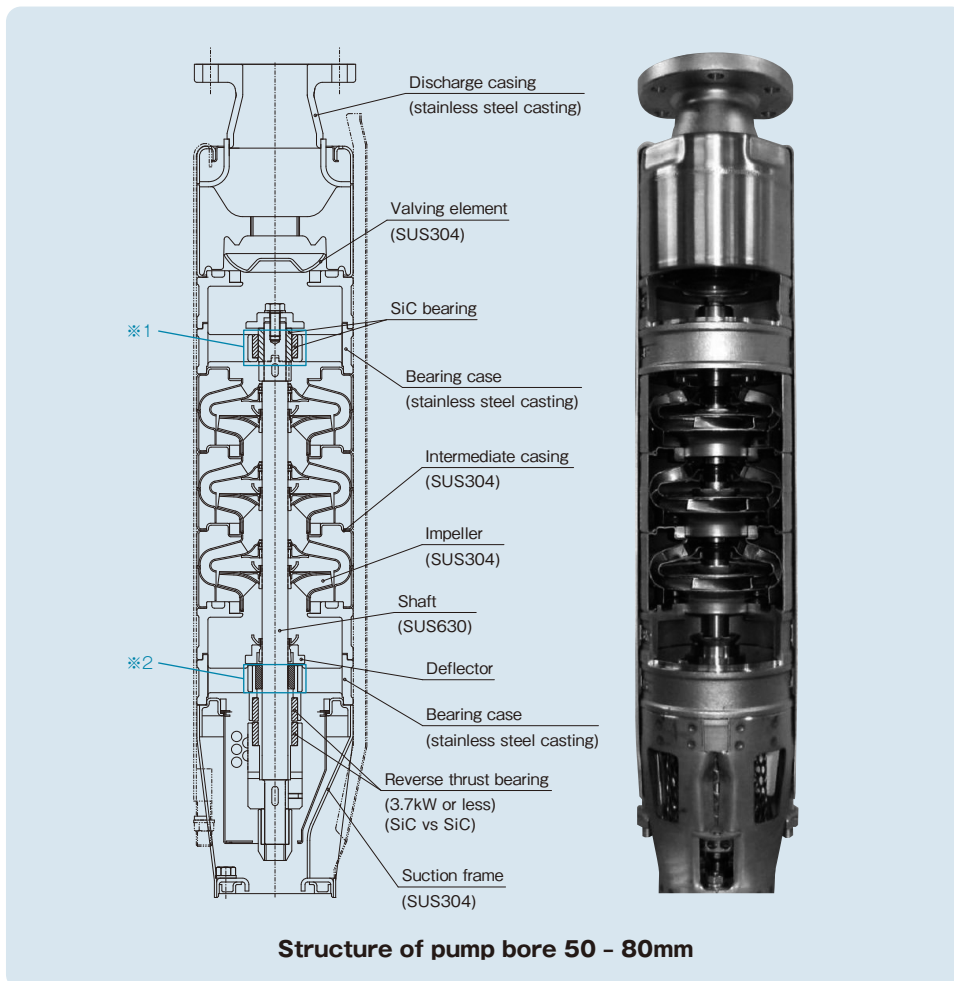

■ Standard specifications

Applicable well diameter (mm)		100 (4B) or more	150 (6B) or more		200 (8B) or more		
Applicable type		25MSUS4-A 32MSUS4-A 40MSUS4-A 50MSUS4	50MSUS6 65MSUS6 80MSUS6	50A-MSUS6 65A-MSUS6 65B-MSUS6 80B-MSUS6	80MSUS8 100MSUS8	80C-MSUS8	
Liquid handled	Liquid quality	Fresh water					
	Allowable liquid temperature	0 - 40°C (Minimum flow rate through the motor 4.5m/min)		0 - 30°C			
	pH	5.8 - 8.6					
	Amount of Chloride	200mg/L or less					
	Amount of sand	50mg/L (size 0.1 - 0.25mm) or less					
Maximum allowable submergence depth of pump (m)		0.6 - 2.2kW 70m	M4 1.9 - 2.2kW 70m		3.7 - 18.5kW 350m		
		2.7 - 3.7kW 210m	M4 2.7 - 3.7kW 210m		22 - 37kW 150m		
			M6 3.7 - 15kW 350m				
Minimum required submergence depth of pump (m)		0.5m	1.0m		1.5m		
Minimum well inner diameter (mm)		100	146 (VP acceptable)		205		
Pump	Range	Bore (mm)	25 - 50	50 - 80		80-100	80
		Output (kW)	0.6 - 3.7	1.9 - 15		3.7 - 37	
	Material	Refer to specifications such as sectional drawing.					
Submersible motor	Frame number	M4	M4 1.9 - 3.7kW M6 3.7 - 15kW		M6 3.7 - 18.5kW M8 22 - 37kW		
	Type	Canned type					
	Poles/Phase/Voltage	2-pole, 3-phase, 200V					
	Starting method	Direct-on-Line start	7.5kW or less: Direct-on-Line start 11kW or more: Star-delta start				
	Insulation class	Class A	M4 class A M6 class F		M6 class F M8 class F (22kW) M8 class E (26, 30, 37kW)		
Piping connection	Pump body	Threaded type	Flange type				
	Discharge bent pipe (aboveground side)	Flange type					

Standard specifications

Applicable well diameter (mm)		75 (3B)	125 (5B) or more	150 (6B) or more	200 (8B) or more	250 (10B) or more	300 (12B) or more	350 (14B) or more	400 (16B) or more	
Applicable type		25MSU3	40MSU5	40MSU6	80MSU8 100MSU8	100MSU10 125MSU10	150MSU12	200MSU14	250MSU16	
Liquid handled	Liquid quality	Fresh water								
	Allowable liquid temperature	0 - 25°C	0 - 40°C	0 - 30°C	0 - 25°C					
	pH	5.8 - 8.6								
	Amount of Chloride	200mg/L or less								
	Amount of sand	50mg/L (size 0.1 - 0.25mm) or less								
Maximum allowable submergence depth of pump (m)		50m	100m	350m	3.7 - 18.5kW 350m 22kW or more 100m	3.7 - 18.5kW 350m 22kW or more 100m		100m		
Minimum required submergence depth of pump (m)		1m	0.5m	0.5m	1.5m	2.5m	3.5m	5.5m	7.5m	
Minimum well inner diameter (mm)		75 (VP acceptable)	125 (VP acceptable)	146 (VP acceptable)	205	254.2	304.7	339.8	390.6	
Pump	Range	Bore (mm)	25	40		80-100	125	150	200	250
		Output (kW)	0.4, 0.75	1.5 - 3.7	5.5 - 7.5	3.7 - 37	7.5 - 55	11 - 75	30 - 75	22 - 75
	Material	Refer to specifications such as sectional drawing.								
Submersible motor	Frame number	M3	M4	M6	M6 3.7 - 18.5kW M8 22 - 37kW	M6 7.5 - 18.5kW M8 22 - 37kW M10 45 - 55kW	M6 11 - 18.5kW M8 22 - 37kW M12 45 - 75kW	M8 30 - 37kW M12 45 - 75kW	M10 22-55kW M12 75kW	
	Type	Canned type				M6 canned type M8 Waterproof insulated M10 Waterproof insulated	M6 canned type M8 Waterproof insulated M12 Waterproof insulated	Waterproof insulated		
	Poles/Phase/Voltage	2-pole, 3-phase, 200V							4-pole, 3-phase, 200V	
	Starting method	Direct-on-Line start				7.5kW or less: Direct-on-Line start 11kW or more: Star-delta start				
	Insulation class	Class E	1.5kW class F 2.2kW or more class E	Class F	M6 class F M8 class Y	M6 class F M8,10,12 class Y		Class Y		
Piping connection	Pump body	Threaded type			Flange type					
	Discharge bent pipe (aboveground side)	Flange type								

Standard specifications

Applicable well diameter (mm)		100 (4B) or more	150 (6B) or more	
Applicable type		25MSUH4 32MSUH4 40MSUH4 50MSUH4	50MSUH6 65MSUH6	50MSUH6 65MSUH6 80MSUH6
Liquid handled	Liquid quality	For simple hot spring or warm water ^{※1}		
	Allowable liquid temperature	75°C (Minimum flow rate through the motor velocity 4.5m/min)	90°C (Minimum flow rate through the motor velocity 9m/min)	
	pH	5.8 - 8.6		
	Amount of Chloride	200mg/L or less		
	Amount of sand	50mg/L (size 0.1 - 0.25mm) or less		
Maximum allowable submergence depth of pump (m)		210m	350m	
Minimum required submergence depth of pump (m)		0.5m	1.0m	
Minimum well inner diameter (mm)		100	146 (VP acceptable)	
Maximum pump outer diameter (mm)		97	142	
Pump	Range	Bore (mm)	25 - 50	50 - 80
		Output (kW)	0.6 - 3.7	3.7
	Material	Refer to specifications such as sectional drawing.		
Submersible motor	Frame number	M4		M6
	Type	Canned type		
	Poles/Phase/Voltage	2-pole, 3-phase, 200V		
	Starting method	Direct-on-Line start		7.5kW or less: Direct-on-Line start 11kW or more: Star-delta start
	Insulation class	Class A		Class F
Piping connection	Pump body	Threaded type	Flange type	
	Discharge bent pipe (aboveground side)	Flange type		

※ 1 Simple hot spring: A hot spring that is always 25°C or more with solid components and free carbon dioxide contained per kilogram of water less than 1g. Contact us for special hot springs (carbonate springs, sulfurous springs, chalybeate springs, salt springs, and sodium bicarbonate springs), etc.

Special specifications

Motor Voltage change

Standard accessories

Submersible check valve (built-in the pump) 1
 Discharge companion flange (except threaded type and 80MSUS8/100MSUS8) 1

Special accessories

- Well cover (with air valve and companion flange)
- Companion flange (for 80MSUS8/100MSUS8)
- Control panel
- Liquid level relay
- Compound gauge
- Extension cable
- Lifting pipe
- Check valve
- Gate valve
- Anchor bolt
- Electrode rod and cable for electrode rod

Description of types

32 MSUS 4 - 5 1.5 - 20 A

① ② ③ ④ ⑤ ⑥ ⑦

- ① Bore diameter
- ② Model MSU: Cast-iron pump
MSUS: Stainless steel pump
MSUH: For hot spring (simple hot spring)
- ③ Well diameter 4inch: 100mm
5inch: 125mm
6inch: 150mm
8inch: 200mm
10inch: 250mm etc.
- ④ Frequency 5 : 50Hz
6 : 60Hz
- ⑤ Output
- ⑥ Number of stage
- ⑦ Series No.

50 A - MSUS 6 - 5 3.7 - 8

① ② ③ ④ ⑤ ⑥ ⑦

- ① Bore diameter
- ② Impeller type
- ③ Model
- ④ Well diameter 6inch: 150mm
8inch: 200mm
- ⑤ Frequency 5 : 50Hz
6 : 60Hz
- ⑥ Output
- ⑦ Number of stage

Proper operating range of pumps

Ensure that the pump discharge rate remains within the specified range (see the specification table).

If the discharge rate is too low, the motor may overheat and burn out. Operating outside the specified range may also cause damage to pump components.

When using the pump in a well with a diameter larger than the applicable well diameter, please make sure to maintain the minimum required discharge rate as indicated below.

Minimum required discharge rate

Pump model	Motor output (kW)	Frame No.	Well diameter / Minimum required discharge rate (m ³ /min)							
			75A (3B)	100A (4B)	125A (5B)	150A (6B)	200A (8B)	250A (10B)	300A (12B)	
MSU3	All output	M3		0.025	0.040					
MSUS4	All output	M4			0.035	0.060				
MSU5	3.7kW or less	M4				0.050	0.105			
	5.5kW or more	M6								
MSUS6	3.7kW or less	M4					0.125	0.205	0.310	
	80MSUS6(3.7kW)	M6					0.180	0.345	0.550	
	5.5kW or more	M6					0.180	0.345	0.550	

Note) Applicable well diameter

Pump model	Motor output (kW)	Frame No.	Well diameter / Minimum required discharge rate (m ³ /min)							
			200A (8B)	250A (10B)	300A (12B)	350A (14B)	400A (16B)	450A (18B)	500A (20B)	
MSUS8	18.5kW or less	M6		0.345	0.550	0.715				
	22kW or more	M8		0.165	0.300	0.410				
MSU8	18.5kW or less	M6		0.345	0.550	0.715				
	22kW or more	M8		0.155	0.290	0.400				
MSU10	18.5kW or less	M6			0.550	0.715				
	22kW - 37kW	M8			0.290	0.400				
	45kW or more	M10			0.230	0.340				
MSU12	18.5kW or less	M6				0.715	0.980			
	22kW - 37kW	M8				0.400	0.580			
	45kW or more	M12				0.225	0.405			
MSU14	37kW or less	M8					0.580	0.785		
	45kW or more	M12					0.405	0.605		
MSU16	22kW - 55kW	M10						0.725	0.950	
	75kW	M12						0.605	0.835	

Note) Applicable well diameter

Pump model	Motor output (kW)	Frame No.	Well diameter / Minimum required discharge rate (m ³ /min)					
			100A (4B)	125A (5B)	150A (6B)	200A (8B)	250A (10B)	300A (12B)
MSUH4	All output (Liquid temperature 40°C or less)	M4		0.035	0.060			
	All output (Liquid temperature over 40°C)		0.040	0.130	0.235			
MSUH6	3.7kW or less (Liquid temperature 40°C or less)	M4				0.125	0.205	
	3.7kW or less (Liquid temperature over 40°C)	M4			0.235	0.495		
	80MSUH6(3.7kW)	M6				0.180	0.345	
	5.5kW or more	M6				0.180	0.345	

Note) Applicable well diameter

Well diameter 100mm / Pump bore 25 - 50mm

Selection chart

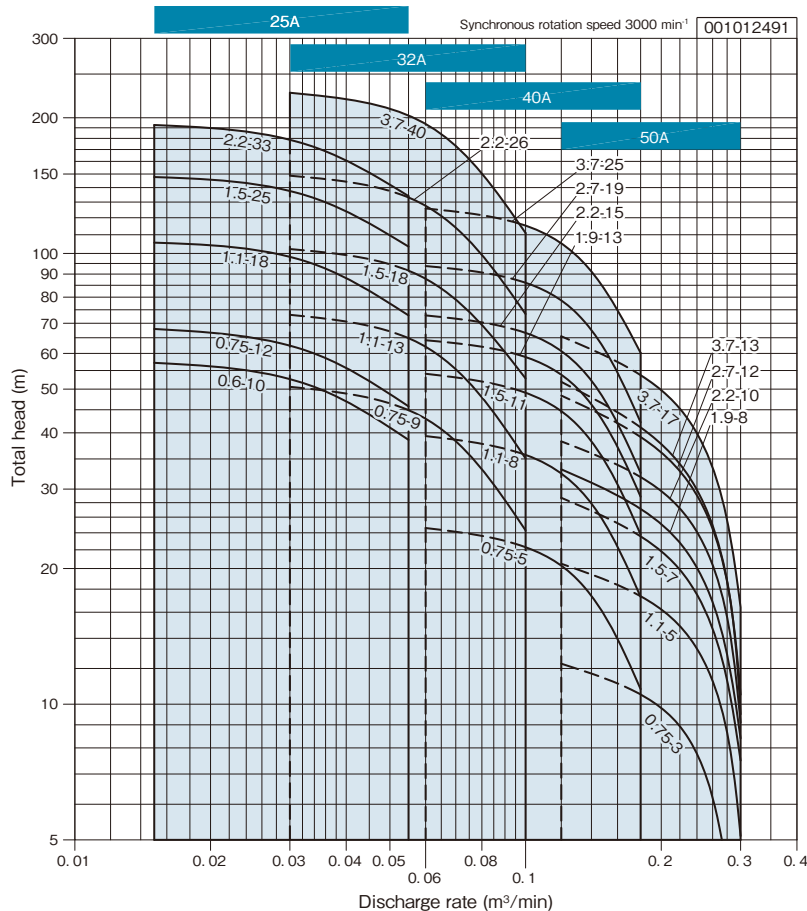

Note: The performance evaluation standard applies JIS B 8301:2018 Acceptance Grade 3B.

Specifications table

Synchronous rotation speed 3000 min⁻¹

Well diameter (mm)	Bore (mm)	Type	No. of stages	Output (kW)	Rated current (A)	Specifications					
						Discharge rate (m ³ /min)	Total head (m)	Discharge rate (m ³ /min)	Total head (m)	Discharge rate (m ³ /min)	Total head (m)
100	25	25MSUS4-5.6-10A	10	0.6	3.5	0.015	57.2	0.035	50.0	0.055	38.6
		25MSUS4-5.75-12A	12	0.75	4.2	0.015	68.0	0.035	59.3	0.055	45.8
		25MSUS4-51.1-18A	18	1.1	6.2	0.015	105.7	0.035	93.6	0.055	72.9
		25MSUS4-51.5-25A	25	1.5	8.6	0.015	147.8	0.035	131.3	0.055	103.6
		25MSUS4-52.2-33A	33	2.2	11.3	0.015	192.8	0.035	170.4	0.055	134.1
	(25) 32	32MSUS4-5.75-9A	9	0.75	4.2	0.030	50.6	0.060	43.0	0.100	24.3
		32MSUS4-51.1-13A	13	1.1	6.2	0.030	73.1	0.060	62.1	0.100	35.1
		32MSUS4-51.5-18A	18	1.5	8.6	0.030	102.3	0.060	87.9	0.100	52.8
		32MSUS4-52.2-26A	26	2.2	11.3	0.030	148.8	0.060	127.6	0.100	73.4
		32MSUS4-53.7-40A	40	3.7	19.3	0.030	227.3	0.060	193.9	0.100	111.0
	(25) 40	40MSUS4-5.75-5A	5	0.75	4.2	0.060	24.6	0.120	20.3	0.180	10.8
		40MSUS4-51.1-8A	8	1.1	6.2	0.060	39.4	0.120	32.5	0.180	17.3
		40MSUS4-51.5-11A	11	1.5	8.6	0.060	54.1	0.120	44.7	0.180	23.8
		40MSUS4-51.9-13A	13	1.9	9.7	0.060	64.2	0.120	53.8	0.180	28.9
		40MSUS4-52.2-15A	15	2.2	11.3	0.060	72.9	0.120	60.8	0.180	32.6
		40MSUS4-52.7-19A	19	2.7	15.0	0.060	93.8	0.120	78.7	0.180	42.2
		40MSUS4-53.7-25A	25	3.7	19.3	0.060	125.9	0.120	105.4	0.180	60.2
		40MSUS4-53.7-17	17	3.7	19.3	0.120	65.5	—	—	—	—
	(25) 50	50MSUS4-5.75-3	3	0.75	4.2	0.120	12.3	—	—	—	—
		50MSUS4-51.1-5	5	1.1	6.2	0.120	20.5	—	—	—	—
50MSUS4-51.5-7		7	1.5	8.6	0.120	28.7	—	—	—	—	
50MSUS4-51.9-8		8	1.9	9.7	0.120	33.2	—	—	—	—	
50MSUS4-52.2-10		10	2.2	11.3	0.120	38.3	—	—	—	—	
50MSUS4-52.7-12		12	2.7	15.0	0.120	48.4	—	—	—	—	
50MSUS4-53.7-13		13	3.7	19.3	0.120	51.9	—	—	—	—	

Note 1) Bore(25) and (32) are for well regulation areas. For details, please contact us.

Well diameter 150mm / Pump bore 50 - 80mm Impeller made of SUS304

■ Selection chart

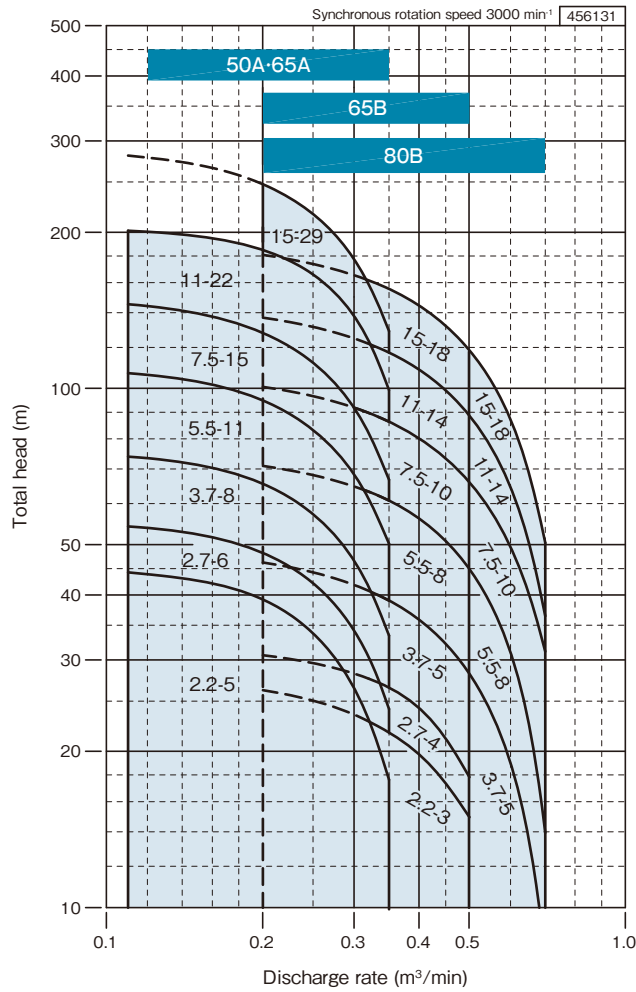

■ Specifications table

Well diameter (mm)	Bore (mm)	Type	No. of stages	Output (kW)	Rated current (A)	Specifications	
						Discharge rate (m ³ /min)	Total head (m)
150	50	50A-MSUS6-52.2-5	5	2.2	11.3	0.2	39.2
		50A-MSUS6-52.7-6	6	2.7	15	0.2	48.2
		50A-MSUS6-53.7-8	8	3.7	19.3	0.2	65.5
		50A-MSUS6-55.5-11	11	5.5	26.5	0.2	94.8
		50A-MSUS6-57.5-15	15	7.5	35	0.2	127.9
		50A-MSUS6-511-22	22	11	52.5	0.2	184.8
	65	65A-MSUS6-52.2-5	5	2.2	11.3	0.2	39.2
		65A-MSUS6-52.7-6	6	2.7	15	0.2	48.2
		65A-MSUS6-53.7-8	8	3.7	19.3	0.2	65.5
		65A-MSUS6-55.5-11	11	5.5	26.5	0.2	94.8
		65A-MSUS6-57.5-15	15	7.5	35	0.2	127.9
		65A-MSUS6-511-22	22	11	52.5	0.2	184.8
		65A-MSUS6-515-29	29	15	69	0.2	247.4
		65B-MSUS6-52.2-3	3	2.2	11.3	0.35	21.7
		65B-MSUS6-52.7-4	4	2.7	15	0.35	26.5
		65B-MSUS6-53.7-5	5	3.7	19.3	0.35	39.0
		65B-MSUS6-55.5-8	8	5.5	26.5	0.35	60.8
		65B-MSUS6-57.5-10	10	7.5	35	0.35	86.3
	65B-MSUS6-511-14	14	11	52.5	0.35	117.2	
	65B-MSUS6-515-18	18	15	69	0.35	155.5	
	80	80B-MSUS6-53.7-5	5	3.7	19.3	0.35	39.0
		80B-MSUS6-55.5-8	8	5.5	26.5	0.35	60.8
		80B-MSUS6-57.5-10	10	7.5	35	0.35	86.3
		80B-MSUS6-511-14	14	11	52.5	0.35	117.2
80B-MSUS6-515-18		18	15	69	0.35	155.5	

Well diameter 150mm / Pump bore 50 - 80mm Impeller made of SCS13

Selection chart

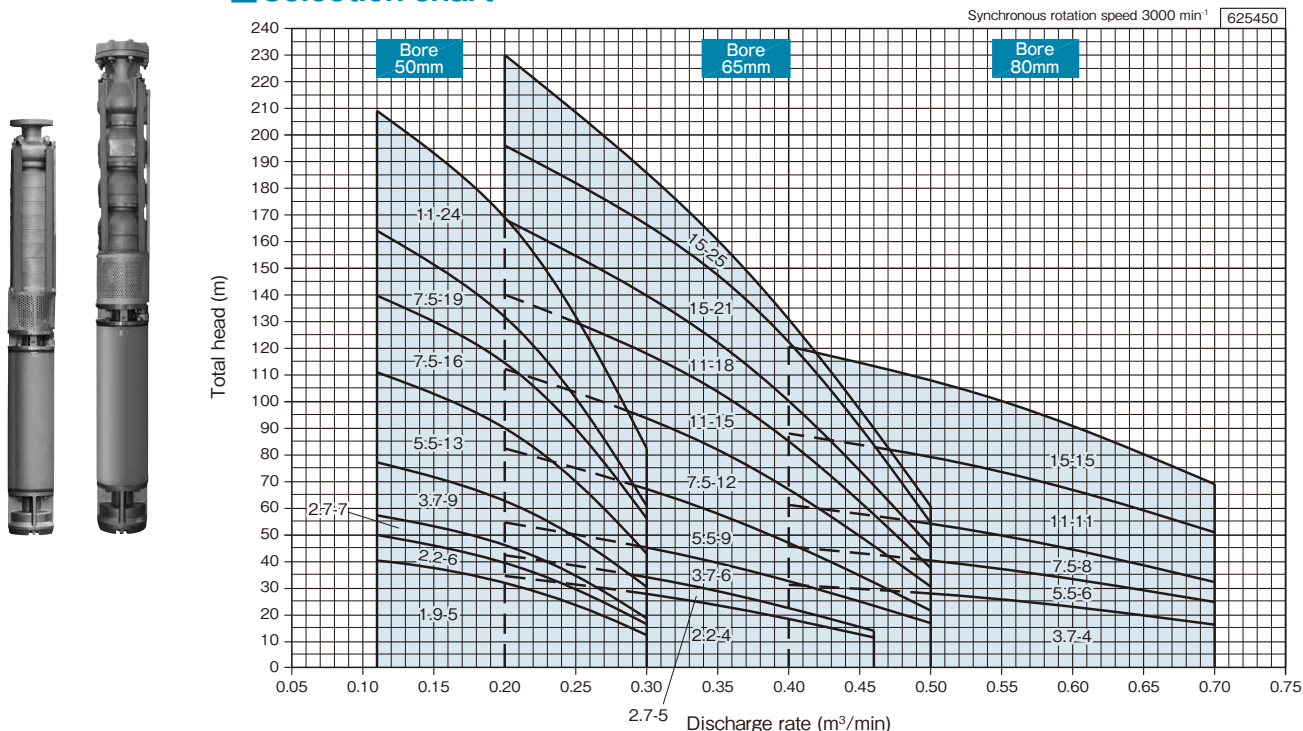

Specifications table

Synchronous rotation speed 3000 min⁻¹

Well diameter (mm)	Bore (mm)	Type	No. of stages	Output (kW)	Rated current (A)	Specifications	
						Discharge rate (m ³ /min)	Total head (m)
150	50	50MSUS6-51.9-5	5	1.9	9.7	0.2	31.7
		50MSUS6-52.2-6	6	2.2	11.3	0.2	39.2
		50MSUS6-52.7-7	7	2.7	15	0.2	45.9
		50MSUS6-53.7-9	9	3.7	19.3	0.2	62.5
		50MSUS6-55.5-13	13	5.5	26.5	0.2	89.8
		50MSUS6-57.5-16	16	7.5	35	0.2	114.3
		50MSUS6-57.5-19	19	7.5	35	0.2	131.6
		50MSUS6-511-24	24	11	52.5	0.2	169.0
	65	65MSUS6-52.2-4	4	2.2	11.3	0.35	23.3
		65MSUS6-52.7-5	5	2.7	15	0.35	28.6
		65MSUS6-53.7-6	6	3.7	19.3	0.35	39.2
		65MSUS6-55.5-9	9	5.5	26.5	0.35	57.7
		65MSUS6-57.5-12	12	7.5	35	0.35	81.7
		65MSUS6-511-15	15	11	52.5	0.35	103.5
		65MSUS6-511-18	18	11	52.5	0.35	122.0
		65MSUS6-515-21	21	15	69	0.35	147.3
	65MSUS6-515-25	25	15	69	0.35	160.4	
	80	80MSUS6-53.7-4	4	3.7	18.5	0.55	25.5
		80MSUS6-55.5-6	6	5.5	26.5	0.55	36.9
		80MSUS6-57.5-8	8	7.5	35	0.55	49.5
		80MSUS6-511-11	11	11	52.5	0.55	73.4
		80MSUS6-515-15	15	15	69	0.55	100.0

Well diameter 200mm / Pump bore 80mm Impeller made of SUS304

■ Selection chart

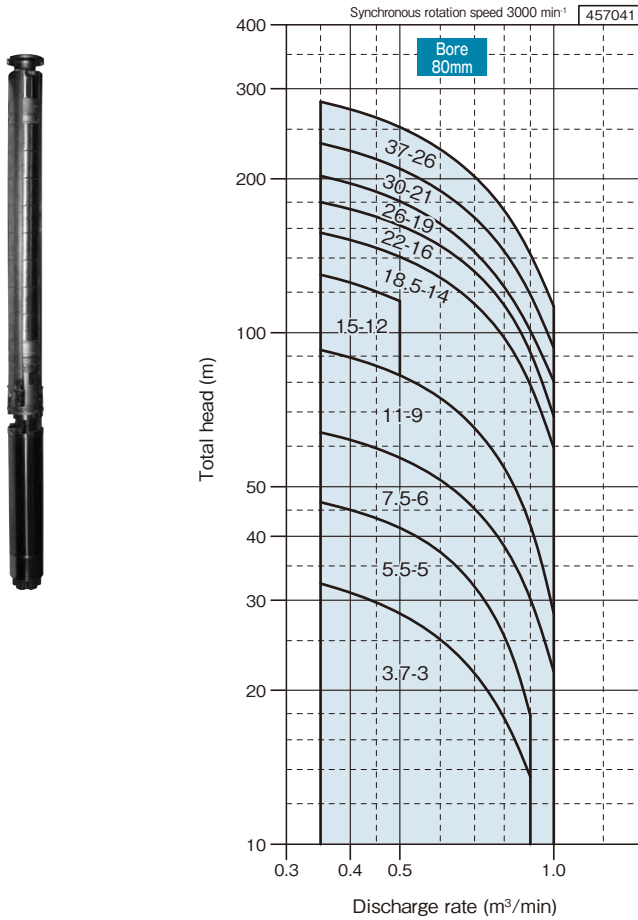

■ Specifications table

Synchronous rotation speed 3000 min⁻¹

Well diameter (mm)	Bore (mm)	Type	No. of stages	Output (kW)	Rated current (A)	Specifications	
						Discharge rate (m ³ /min)	Total head (m)
200	80	80C-MSUS8-53.7-3	3	3.7	18.5	0.6	25.1
		80C-MSUS8-55.5-5	5	5.5	26.5	0.6	37.2
		80C-MSUS8-57.5-6	6	7.5	35	0.6	51.5
		80C-MSUS8-511-9	9	11	52.5	0.6	74.5
		80C-MSUS8-515-12	12	15	69	0.4	125.3
		80C-MSUS8-518-14	14	18.5	84	0.6	128.1
		80C-MSUS8-522-16	16	22	85	0.6	147.9
		80C-MSUS8-526-19	19	26	103	0.6	163.3
		80C-MSUS8-530-21	21	30	118	0.6	189.4
80C-MSUS8-537-26	26	37	144	0.6	228.3		

Well diameter 200mm / Pump bore 80 - 100mm Impeller made of SCS13

Selection chart

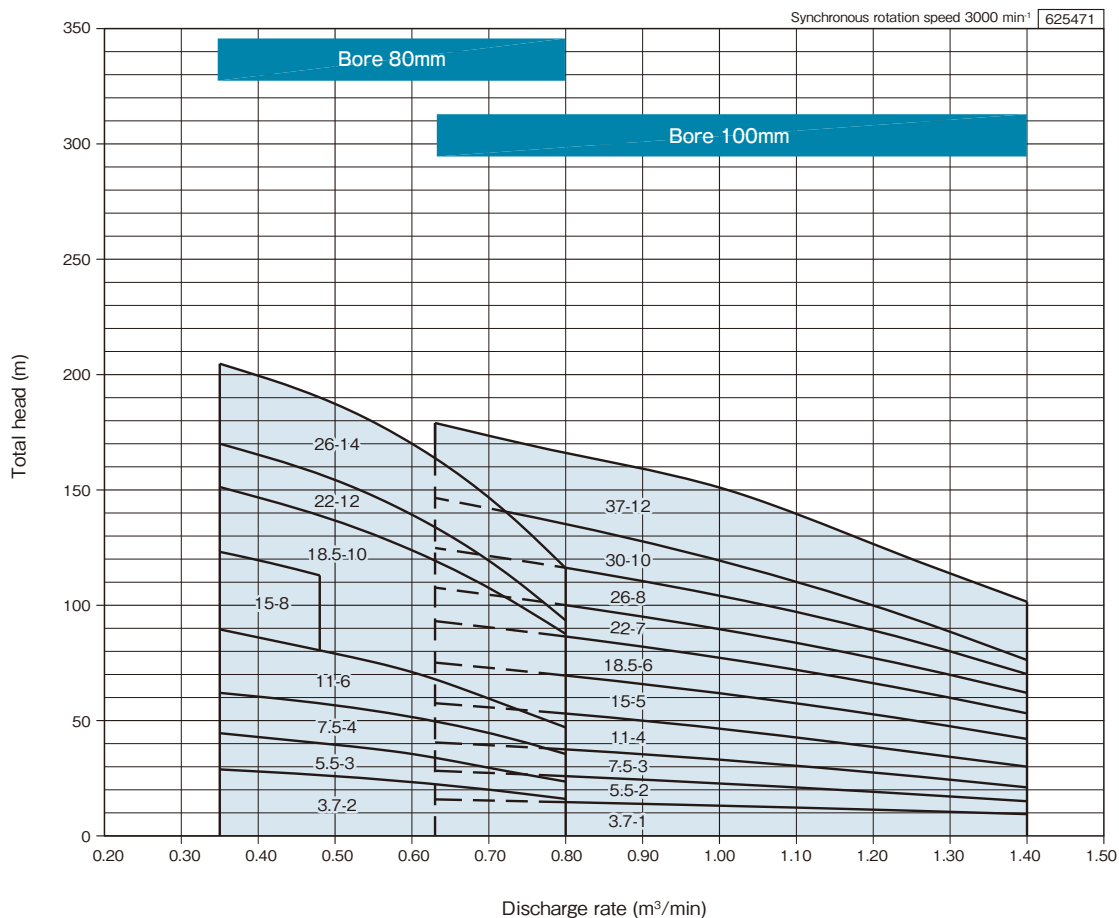

Specifications table

Synchronous rotation speed 3000 min⁻¹

Well diameter (mm)	Bore (mm)	Type	No. of stages	Output (kW)	Rated current (A)	Specifications	
						Discharge rate (m ³ /min)	Total head (m)
200	80	80MSUS8-53.7-2	2	3.7	18.5	0.6	23.3
		80MSUS8-55.5-3	3	5.5	26.5	0.6	35.5
		80MSUS8-57.5-4	4	7.5	35	0.6	51.5
		80MSUS8-511-6	6	11	52.5	0.6	71.0
		80MSUS8-515-8	8	15	69	0.4	119.5
		80MSUS8-518-10	10	18.5	84	0.6	123.8
		80MSUS8-522-12	12	22	85	0.6	139.2
		80MSUS8-526-14	14	26	103	0.6	170.0
	100	100MSUS8-53.7-1	1	3.7	18.5	1.0	13.1
		100MSUS8-55.5-2	2	5.5	26.5	1.0	22.7
		100MSUS8-57.5-3	3	7.5	35	1.0	33.0
		100MSUS8-511-4	4	11	52.5	1.0	46.5
		100MSUS8-515-5	5	15	69	1.0	61.8
		100MSUS8-518-6	6	18.5	84	1.0	77.2
		100MSUS8-522-7	7	22	85	1.0	89.6
		100MSUS8-526-8	8	26	103	1.0	104.1
		100MSUS8-530-10	10	30	118	1.0	119.3
		100MSUS8-537-12	12	37	144	1.0	151.0

Well diameter 75mm / Pump bore 25mm

Selection chart



● For 75mm well (3B)

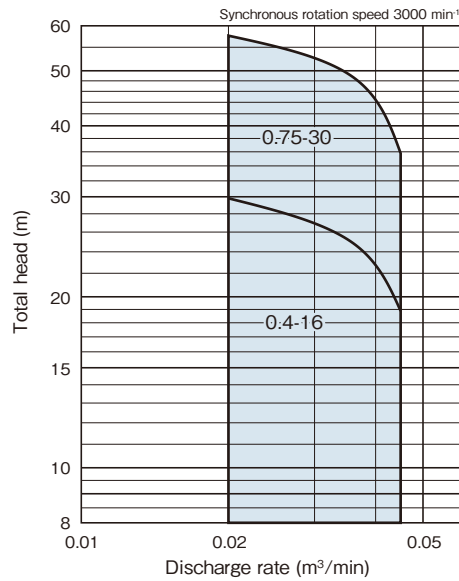

Specifications table

Well diameter (mm)	Bore (mm)	Type	No. of stages	Output (kW)	Rated current (A)	Specifications					
						Discharge rate (m³/min)	Total head (m)	Discharge rate (m³/min)	Total head (m)	Discharge rate (m³/min)	Total head (m)
75	25	25MSU3-5.4-16	16	0.4	3.7	0.02	30	0.036	25	0.045	19
		25MSU3-5.75-30	30	0.75	6.5	0.02	58	0.036	49	0.045	36

Well diameter 125 - 150mm / Pump bore 40mm (25mm)

Selection chart



● For 125mm well (5B)

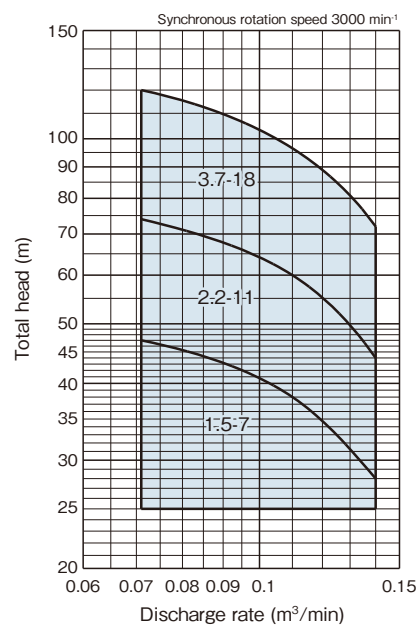

● For 150mm well (6B)

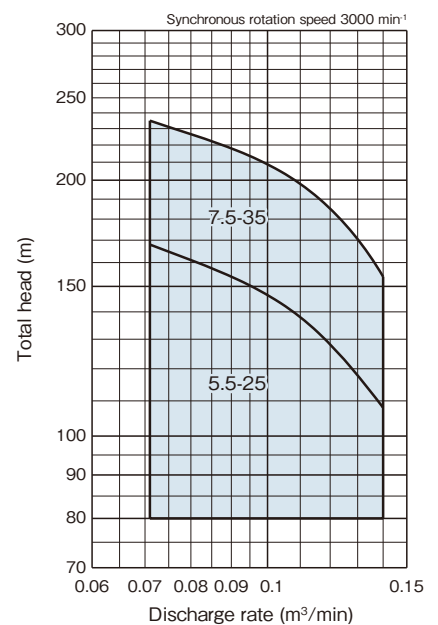

Specifications table

Well diameter (mm)	Bore (mm)	Type	No. of stages	Output (kW)	Rated current (A)	Specifications					
						Discharge rate (m³/min)	Total head (m)	Discharge rate (m³/min)	Total head (m)	Discharge rate (m³/min)	Total head (m)
125	(25) 40	40MSU5-51.5-7	7	1.5	8.4	0.071	47	0.11	38	0.14	28
		40MSU5-52.2-11	11	2.2	12.3	0.071	74	0.11	60	0.14	44
		40MSU5-53.7-18	18	3.7	19.7	0.071	120	0.11	96.5	0.14	72
150	(25) 40	40MSU6-55.5-25	25	5.5	26.5	0.071	168	0.11	138	0.14	108
		40MSU6-57.5-35	35	7.5	35	0.071	235	0.11	198	0.14	154

* Bore (25) is for control areas.

Well diameter 200mm / Pump bore 80 - 100mm

Selection chart

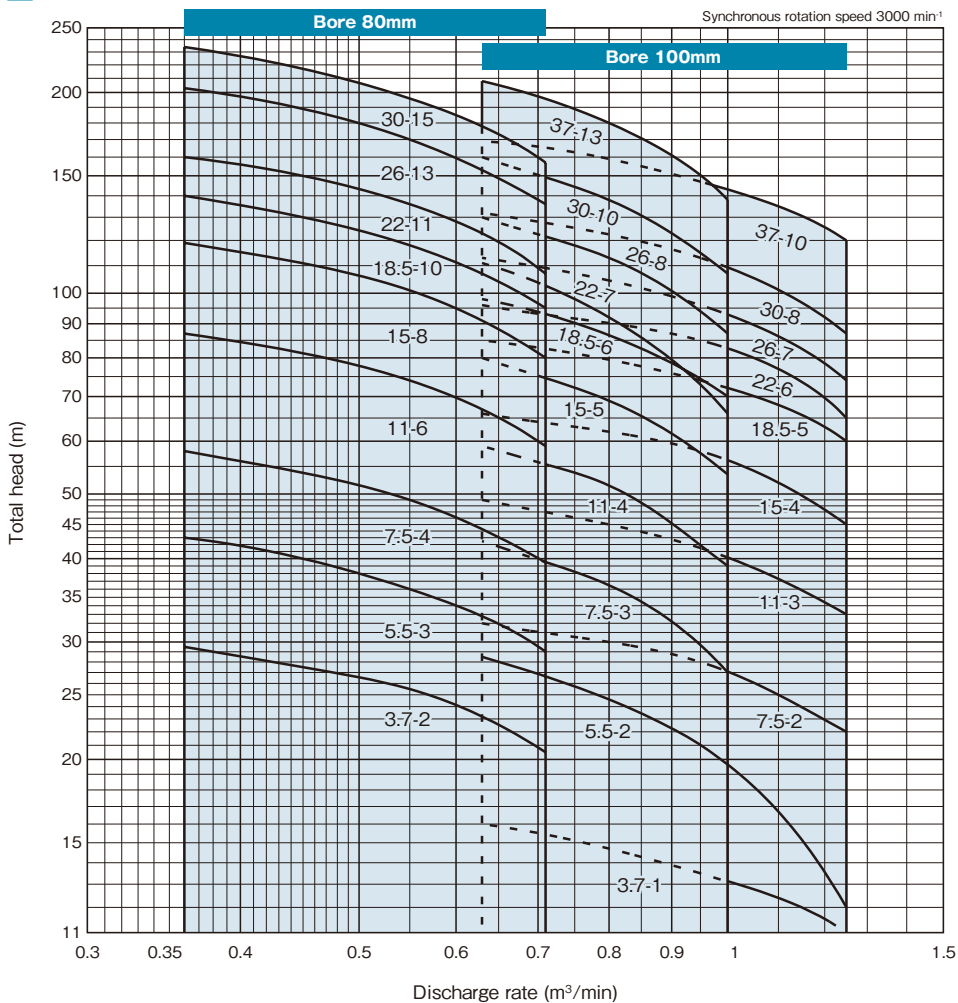

Specifications table

Well diameter (mm)	Bore (mm)	Type	No. of stages	Output (kW)	Rated current (A)	Specifications					
						Discharge rate (m³/min)	Total head (m)	Discharge rate (m³/min)	Total head (m)	Discharge rate (m³/min)	Total head (m)
200	80	80MSU8-53.7-2	2	3.7	18.5	0.36	29.5	0.55	25.5	0.71	20.5
		80MSU8-55.5-3	3	5.5	26.5	0.36	43	0.55	36	0.71	29
		80MSU8-57.5-4	4	7.5	35	0.36	58	0.55	49	0.71	39.5
		80MSU8-511-6	6	11	52.5	0.36	87	0.55	74	0.71	59
		80MSU8-515-8	8	15	69	0.36	119	0.55	101	0.71	80
		80MSU8-518-10	10	18.5	84	0.36	140	0.55	118	0.71	95
		80MSU8-522-11	11	22	101	0.36	160	0.55	136	0.71	107
		80MSU8-526-13	13	26	114	0.36	203	0.55	170	0.71	136
	80MSU8-530-15	15	30	128	0.36	234	0.55	196	0.71	157	
	100	100MSU8-53.7-1	1	3.7	18.5	0.63	16	0.95	13.5	1.25	11
		100MSU8-55.5-2	2	5.5	26.5	0.63	28.5	0.95	21	1.25	12
		100MSU8-57.5-2	2	7.5	35	0.63	32	0.95	28	1.25	22
		100MSU8-57.5-3	3	7.5	35	0.63	42.5	0.80	36.5	1.00	27
		100MSU8-511-3	3	11	52.5	0.63	49	0.95	41.5	1.25	33
		100MSU8-511-4	4	11	52.5	0.63	59	0.80	51.5	1.00	39
		100MSU8-515-4	4	15	69	0.63	66	0.95	58	1.25	45
		100MSU8-515-5	5	15	69	0.63	80	0.80	69	1.00	53.5
		100MSU8-518-5	5	18.5	84	0.63	85	0.95	74	1.25	60
		100MSU8-518-6	6	18.5	84	0.63	98	0.80	86.5	1.00	70
		100MSU8-522-6	6	22	101	0.63	96	0.95	85	1.25	65
		100MSU8-522-7	7	22	101	0.63	111	0.80	92	1.00	66
		100MSU8-526-7	7	26	114	0.63	113	0.95	96	1.25	74
		100MSU8-526-8	8	26	114	0.63	130	0.80	113	1.00	87
		100MSU8-530-8	8	30	128	0.63	132	0.95	113	1.25	87
100MSU8-530-10		10	30	128	0.63	160	0.80	138	1.00	107	
100MSU8-537-10	10	37	155	0.63	169	0.95	147	1.25	120		
100MSU8-537-13	13	37	155	0.63	208	0.80	180	1.00	138		

Well diameter 200mm / Pump bore 100mm

■ Selection chart

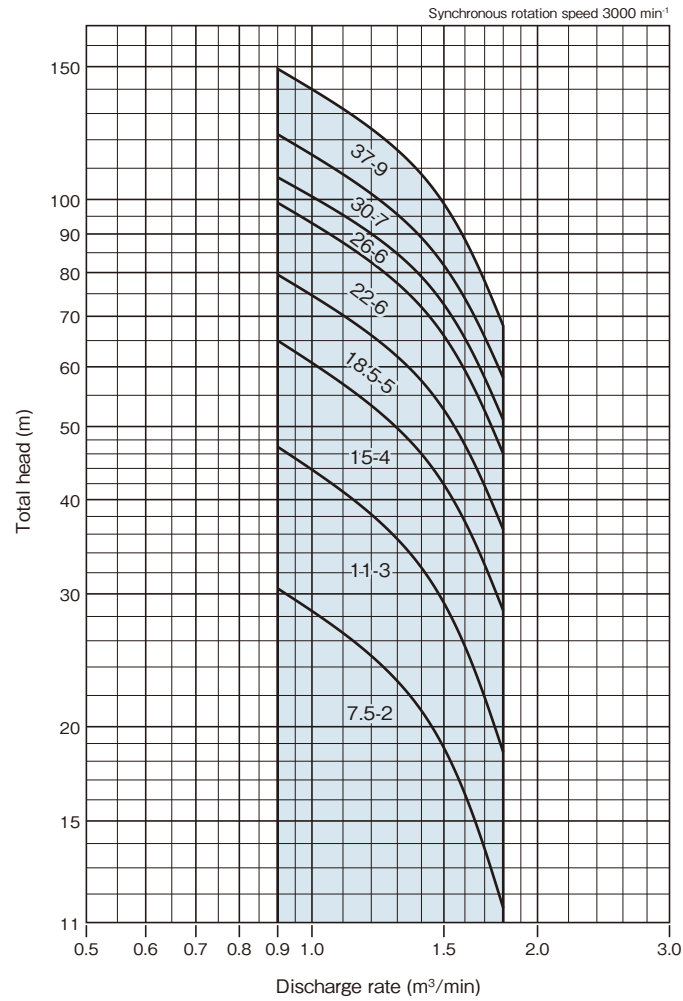

■ Specifications table

Synchronous rotation speed 3000 min⁻¹

Well diameter (mm)	Bore (mm)	Type	No. of stages	Output (kW)	Rated current (A)	Specifications					
						Discharge rate (m ³ /min)	Total head (m)	Discharge rate (m ³ /min)	Total head (m)	Discharge rate (m ³ /min)	Total head (m)
200	100	100MSU8-57.5-2B	2	7.5	35	0.9	30.5	1.4	21	1.8	11.5
		100MSU8-511-3B	3	11	51.5	0.9	47	1.4	32.5	1.8	18.5
		100MSU8-515-4B	4	15	69.3	0.9	65	1.4	46	1.8	28.5
		100MSU8-518-5B	5	18.5	88	0.9	79.5	1.4	57.5	1.8	36.5
		100MSU8-522-6B	6	22	109	0.9	99	1.4	72	1.8	46
		100MSU8-526-6B	6	26	110	0.9	107	1.4	79	1.8	51
		100MSU8-530-7B	7	30	123	0.9	122	1.4	89	1.8	58
		100MSU8-537-9B	9	37	150	0.9	149	1.4	108	1.8	68

Well diameter 250 - 300mm / Pump bore 100 - 150mm

Selection chart



●For 250mm well (10B)

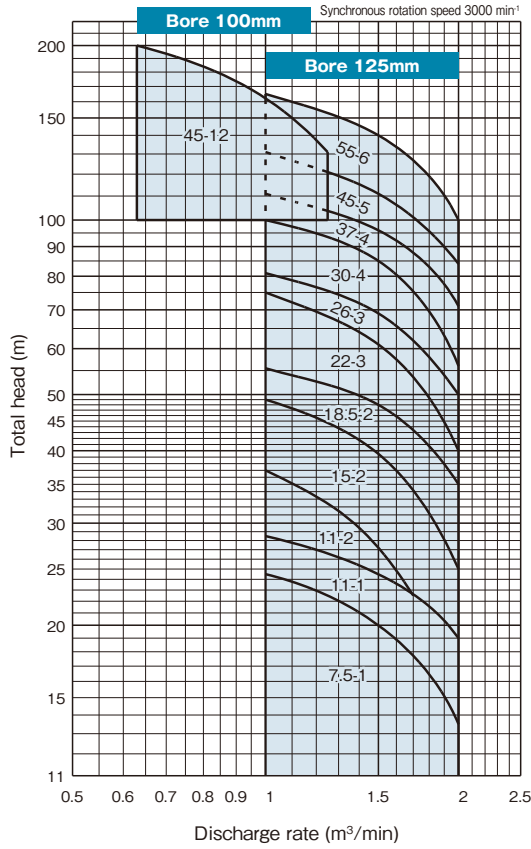

●For 300mm well (12B)

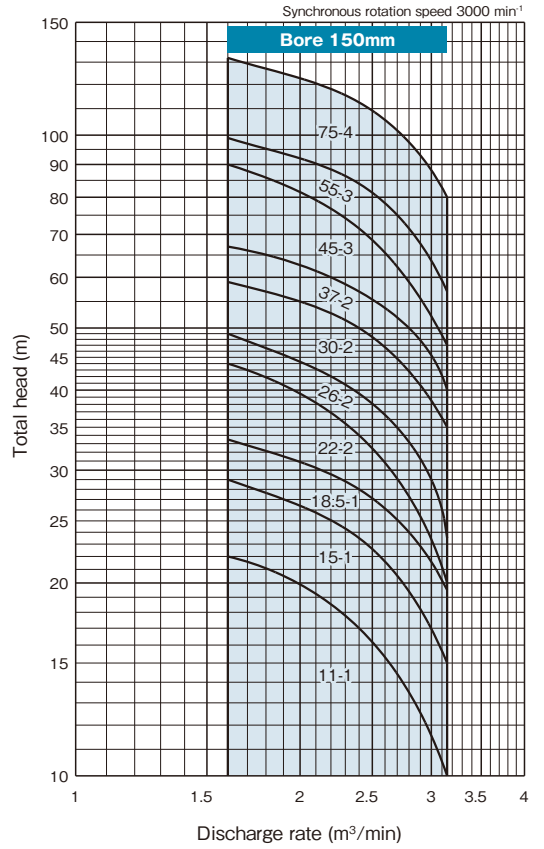

Specifications table

●For 250mm well (10B)

Synchronous rotation speed 3000 min⁻¹

Well diameter (mm)	Bore (mm)	Type	No. of stages	Output (kW)	Rated current (A)	Specifications					
						Discharge rate (m³/min)	Total head (m)	Discharge rate (m³/min)	Total head (m)	Discharge rate (m³/min)	Total head (m)
250	100	100MSU10-545-12	12	45	188	0.63	200	0.95	168	1.25	131
	125	125MSU10-57.5-1	1	7.5	35	1.00	24.5	1.50	20	2.00	13.5
		125MSU10-511-1	1	11	52.5	1.00	28.5	1.50	24.5	2.00	19
		125MSU10-511-2	2	11	52.5	1.00	37	1.35	30.5	1.70	22.5
		125MSU10-515-2	2	15	69	1.00	49	1.50	39.5	2.00	25
		125MSU10-518-2	2	18.5	84	1.00	55.5	1.50	48	2.00	35
		125MSU10-522-3	3	22	101	1.00	75	1.50	61	2.00	40
		125MSU10-526-3	3	26	114	1.00	81	1.50	69	2.00	50
		125MSU10-530-4	4	30	128	1.00	100	1.50	85	2.00	56
		125MSU10-537-4	4	37	155	1.00	111	1.50	96	2.00	71
125MSU10-545-5	5	45	188	1.00	131	1.50	111	2.00	84		
125MSU10-555-6	6	55	230	1.00	165	1.50	140	2.00	100		

●For 300mm well (12B)

Synchronous rotation speed 3000 min⁻¹

Well diameter (mm)	Bore (mm)	Type	No. of stages	Output (kW)	Rated current (A)	Specifications					
						Discharge rate (m³/min)	Total head (m)	Discharge rate (m³/min)	Total head (m)	Discharge rate (m³/min)	Total head (m)
300	150	150MSU12-511-1	1	11	52.5	1.60	22	2.40	17	3.15	10
		150MSU12-515-1	1	15	69	1.60	29	2.40	23.5	3.15	15
		150MSU12-518-1	1	18.5	84	1.60	33.5	2.40	28	3.15	19.5
		150MSU12-522-2	2	22	101	1.60	44	2.40	34	3.15	20
		150MSU12-526-2	2	26	114	1.60	49	2.40	39.5	3.15	23.5
		150MSU12-530-2	2	30	128	1.60	59	2.40	50	3.15	35
		150MSU12-537-2	2	37	155	1.60	67	2.40	57	3.15	40
		150MSU12-545-3	3	45	175	1.60	90	2.40	71.5	3.15	47
		150MSU12-555-3	3	55	210	1.60	99	2.40	84	3.15	57
		150MSU12-575-4	4	75	284	1.60	132	2.40	112.5	3.15	80

Well diameter 350 - 400mm / Pump bore 200 - 250mm

■ Selection chart



● For 350mm well (14B)

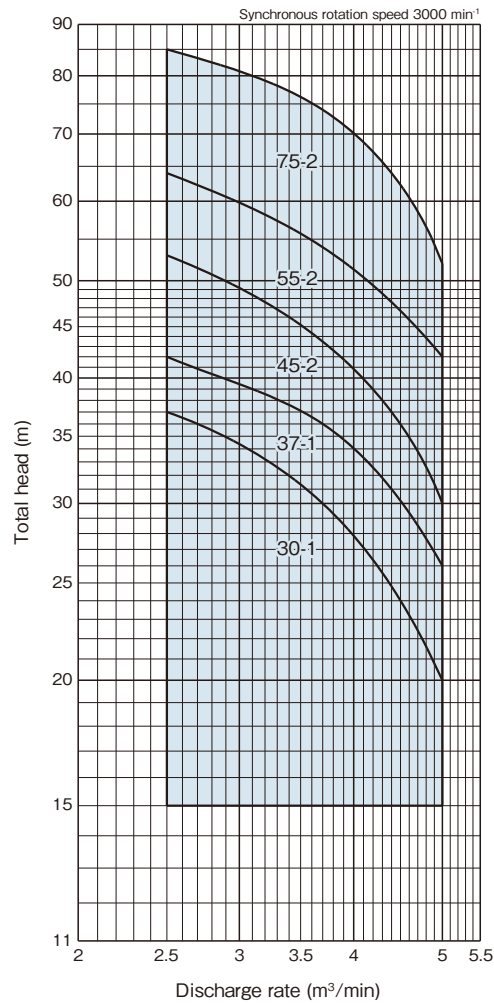

● For 400mm well (16B)

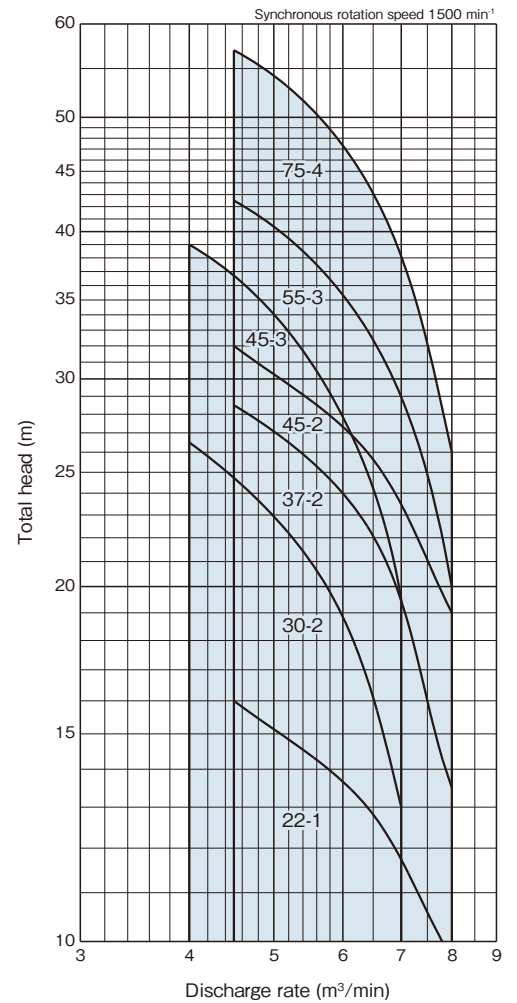

■ Specifications table

● For 350mm well (14B)

Synchronous rotation speed 3000 min⁻¹

Well diameter (mm)	Bore (mm)	Type	No. of stages	Output (kW)	Rated current (A)	Specifications					
						Discharge rate (m³/min)	Total head (m)	Discharge rate (m³/min)	Total head (m)	Discharge rate (m³/min)	Total head (m)
350	200	200MSU14-530-1	1	30	128	2.5	37	3.7	30	5.0	20
		200MSU14-537-1	1	37	155	2.5	42	3.7	36	5.0	26
		200MSU14-545-2	2	45	175	2.5	53	3.7	43.5	5.0	30
		200MSU14-555-2	2	55	210	2.5	64	3.7	54	5.0	42
		200MSU14-575-2	2	75	284	2.5	85	3.7	74	5.0	52

● For 400mm well (16B)

Synchronous rotation speed 1500 min⁻¹

Well diameter (mm)	Bore (mm)	Type	No. of stages	Output (kW)	Rated current (A)	Specifications					
						Discharge rate (m³/min)	Total head (m)	Discharge rate (m³/min)	Total head (m)	Discharge rate (m³/min)	Total head (m)
400	250	250MSU16-522-1	1	22	116	4.5	16	6.4	13	7.8	10
		250MSU16-530-2	2	30	144	4.0	26.5	5.75	20	7.0	13
		250MSU16-537-2	2	37	184	4.5	28.5	6.4	22.5	8.0	13.5
		250MSU16-545-2	2	45	212	4.5	32	6.4	26	8.0	19
		250MSU16-545-3	3	45	212	4.0	39	5.75	29.5	7.0	19.5
		250MSU16-555-3	3	55	138*	4.5	42.5	6.4	33	8.0	20
		250MSU16-575-4	4	75	160*	4.5	57	6.4	44	8.0	26

* For 55kW or more, characteristic values at 400V are shown.

Well diameter 100mm / Pump bore 25 - 50mm

Selection chart

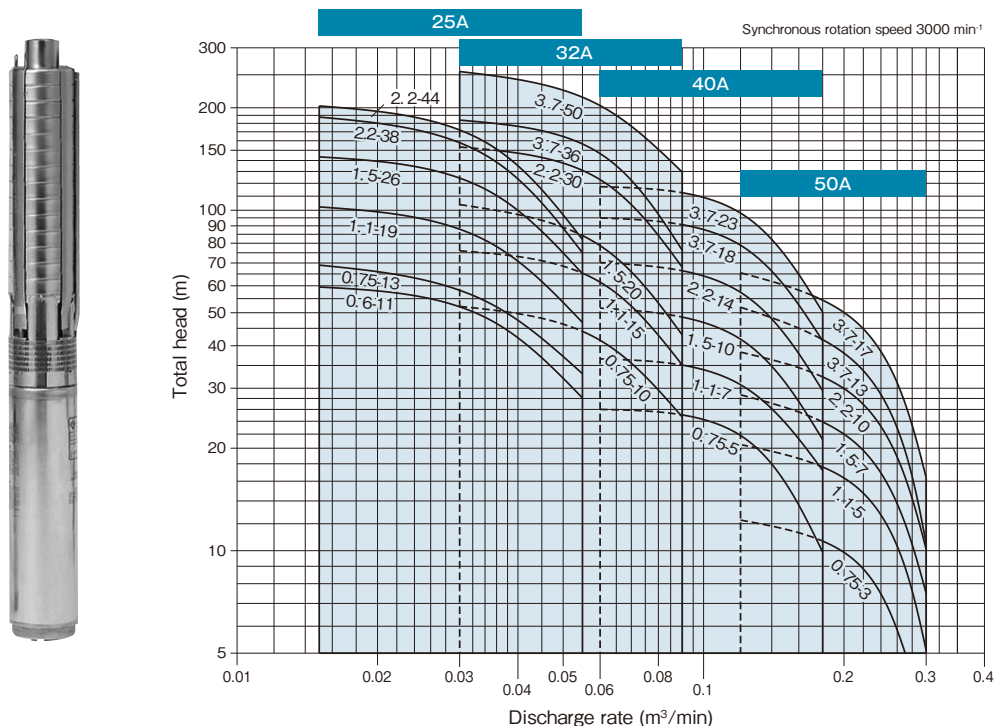

Specifications table

Synchronous rotation speed 3000 min⁻¹

Well diameter (mm)	Bore (mm)	Type	No. of stages	Output (kW)	Rated current (A)	Specifications	
						Discharge rate (m ³ /min)	Total head (m)
100	25	25MSUH4-5.6-11*	11	0.6	4.8	0.015	59.5
		25MSUH4-5.75-13*	13	0.75	6.1	0.015	69.0
		25MSUH4-51.1-19*	19	1.1	7.6	0.015	102.3
		25MSUH4-51.5-26	26	1.5	8.6	0.015	143.5
		25MSUH4-52.2-38	38	2.2	11.3	0.015	187.8
		25MSUH4-52.2-44	44	2.2	11.3	0.015	202.5
	32	32MSUH4-5.75-10*	10	0.75	6.1	0.03	52.2
		32MSUH4-51.1-15*	15	1.1	7.6	0.03	76.0
		32MSUH4-51.5-20	20	1.5	8.6	0.03	103.9
		32MSUH4-52.2-30	30	2.2	11.3	0.03	153.4
		32MSUH4-53.7-36	36	3.7	19.3	0.03	184.0
		32MSUH4-53.7-50	50	3.7	19.3	0.03	255.6
	40	40MSUH4-5.75-5*	5	0.75	6.1	0.06	26.0
		40MSUH4-51.1-7*	7	1.1	7.6	0.06	36.6
		40MSUH4-51.5-10	10	1.5	8.6	0.06	51.6
		40MSUH4-52.2-14	14	2.2	11.3	0.06	70.2
		40MSUH4-53.7-18	18	3.7	19.3	0.06	94.9
		40MSUH4-53.7-23	23	3.7	19.3	0.06	117.3
	50	50MSUH4-5.75-3*	3	0.75	6.1	0.12	12.3
		50MSUH4-51.1-5*	5	1.1	7.6	0.12	20.5
50MSUH4-51.5-7		7	1.5	8.6	0.12	28.7	
50MSUH4-52.2-10		10	2.2	11.3	0.12	38.3	
50MSUH4-53.7-13		13	3.7	19.3	0.12	51.9	
50MSUH4-53.7-17		17	3.7	19.3	0.12	65.5	

For the types marked with *, the motor output is 1.5kW.

Well diameter 150mm / Pump bore 50 - 80mm

Selection chart

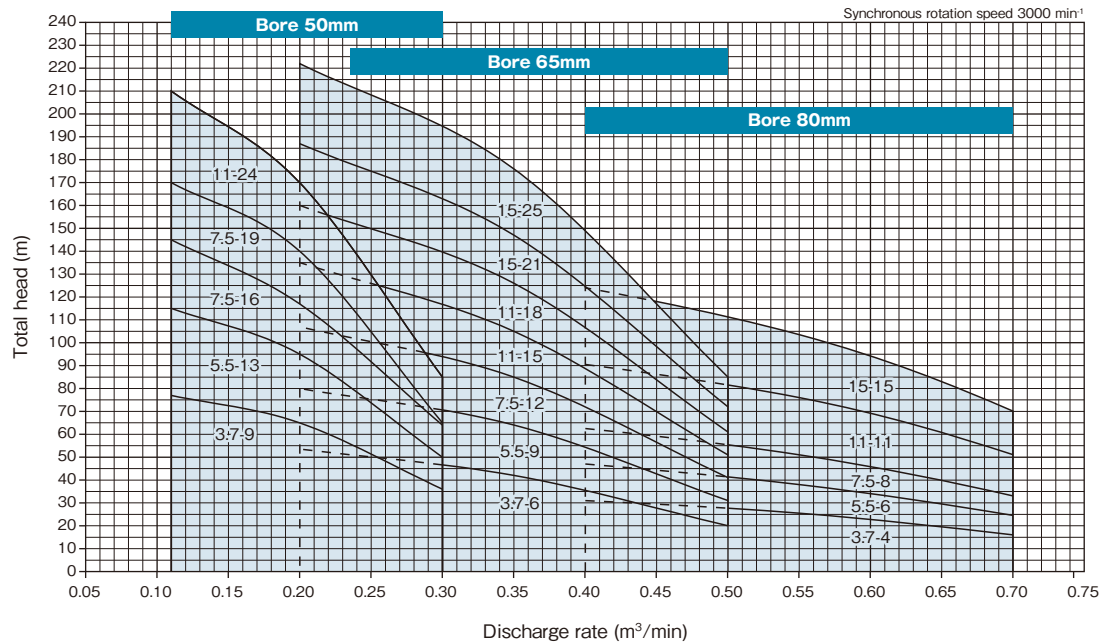

Specifications table

Synchronous rotation speed 3000 min⁻¹

Well diameter (mm)	Bore (mm)	Type	No. of stages	Output (kW)	Rated current (A)	Specifications					
						Discharge rate (m³/min)	Total head (m)	Discharge rate (m³/min)	Total head (m)	Discharge rate (m³/min)	Total head (m)
150	50	50MSUH6-53.7-9	9	3.7	19.3	0.11	77	0.20	65	0.30	36
		50MSUH6-55.5-13	13	5.5	24.6	0.11	115	0.20	95	0.30	50
		50MSUH6-57.5-16	16	7.5	32.6	0.11	145	0.20	117	0.30	64
		50MSUH6-57.5-19	19	7.5	32.6	0.11	170	0.20	140	0.30	65
		50MSUH6-511-24	24	11	48.4	0.11	210	0.20	170	0.30	85
	65	65MSUH6-53.7-6	6	3.7	19.3	0.20	56	0.35	42	0.50	20
		65MSUH6-55.5-9	9	5.5	24.6	0.20	84	0.35	64.5	0.50	30
		65MSUH6-57.5-12	12	7.5	32.6	0.20	112	0.35	86	0.50	40
		65MSUH6-511-15	15	11	48.4	0.20	140	0.35	105	0.50	50
		65MSUH6-511-18	18	11	48.4	0.20	168	0.35	126	0.50	60
		65MSUH6-515-21	21	15	66	0.20	196	0.35	147	0.50	70
	80	80MSUH6-515-25	25	15	66	0.20	233	0.35	179	0.50	83
		80MSUH6-53.7-4	4	3.7	17	0.40	31	0.55	25.5	0.70	16
		80MSUH6-55.5-6	6	5.5	24.6	0.40	47	0.55	38	0.70	24.5
		80MSUH6-57.5-8	8	7.5	32.6	0.40	62.5	0.55	51	0.70	33
80MSUH6-511-11		11	11	48.4	0.40	90.5	0.55	76	0.70	51	
		80MSUH6-515-15	15	15	66	0.40	124	0.55	103.5	0.70	70

Well diameter 100mm / Pump bore 25 - 50mm

■ Assembly drawing

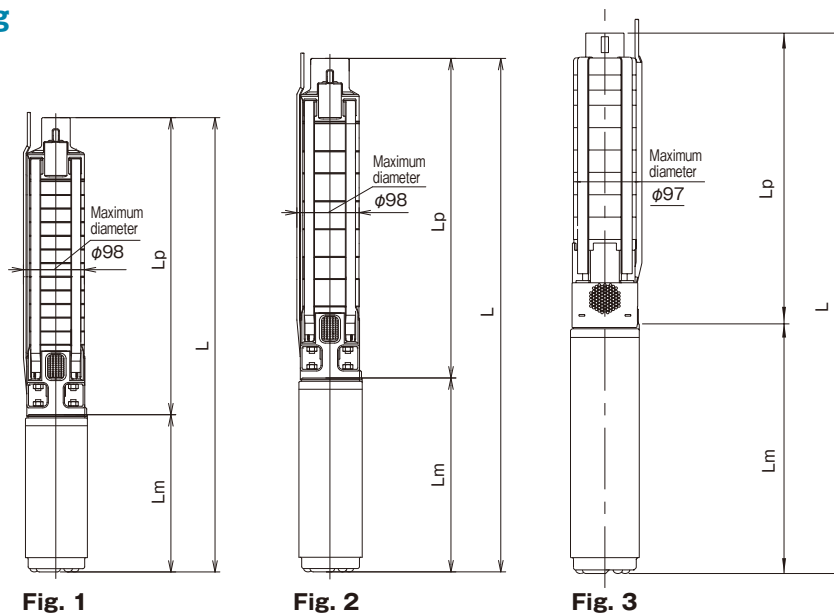

■ Dimensions

Well diameter (mm)	Bore (mm)	Type	Output (kW)	Discharge size	Outer dimensions (mm)			Approx. mass (kg)	Fig.
					L	Lp	Lm		
100	25	25MSUS4-5.6-10A	0.6	Rc1	699	457	242	13.5	1
		25MSUS4-5.75-12A	0.75	Rc1	791	499	292	16.0	
		25MSUS4-51.1-18A	1.1	Rc1	917	625	292	17.5	
		25MSUS4-51.5-25A	1.5	Rc1	1132	793	339	21.5	
		25MSUS4-52.2-33A	2.2	Rc1	1340	961	379	24.5	
	(25) 32	32MSUS4-5.75-9A	0.75	Rc1 1/4	728	436	292	15.5	1
		32MSUS4-51.1-13A	1.1	Rc1 1/4	812	520	292	16.5	
		32MSUS4-51.5-18A	1.5	Rc1 1/4	964	625	339	20.5	
		32MSUS4-52.2-26A	2.2	Rc1 1/4	1193	814	379	24.0	
	(25) (32) 40	40MSUS4-5.75-5A	0.75	Rc1 1/2	773	481	292	15.5	2
		40MSUS4-51.1-8A	1.1	Rc1 1/2	899	607	292	17.0	
		40MSUS4-51.5-11A	1.5	Rc1 1/2	1072	733	339	21.0	
		40MSUS4-51.9-13A	1.9	Rc1 1/2	1229	850	379	23.5	
		40MSUS4-52.2-15A	2.2	Rc1 1/2	1313	934	379	24.5	
		40MSUS4-52.7-19A	2.7	Rc1 1/2	1673	1102	571	35.5	
		40MSUS4-53.7-25A	3.7	Rc1 1/2	1958	1387	571	38.5	
	(25) (32) 50	50MSUS4-5.75-3	0.75	Rc2	679	387	292	15.0	3
		50MSUS4-51.1-5	1.1	Rc2	769	477	292	17.0	
		50MSUS4-51.5-7	1.5	Rc2	906	567	339	20.0	
		50MSUS4-51.9-8	1.9	Rc2	1026	647	379	22.0	
50MSUS4-52.2-10		2.2	Rc2	1116	737	379	23.0		
50MSUS4-52.7-12		2.7	Rc2	1398	827	571	29.0		
50MSUS4-53.7-13		3.7	Rc2	1443	872	571	29.0		
50MSUS4-53.7-17		3.7	Rc2	1658	1087	571	31.0		

Note 1) Bore(25) and (32) are for well regulation areas. For details, please contact us.

Well diameter 150mm / Pump bore 50 - 80mm Impeller made of SUS304

■ Assembly drawing

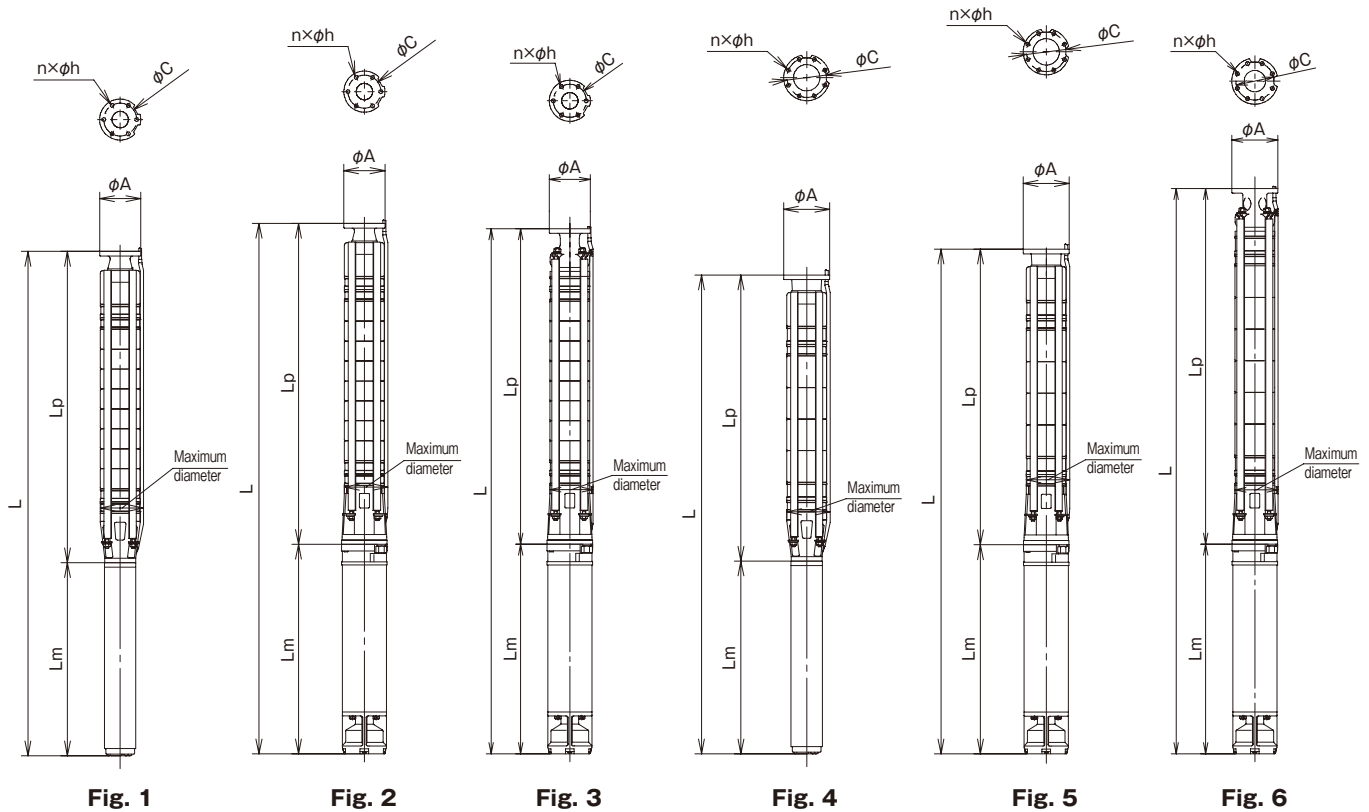

■ Flange dimensions (unit: mm)

Bore	A	C	n	h	Fig.
50	125	100	6	12	1-2-3
65	140	115	8	12	4-5-6
80	140	120	8	12	4-5-6

■ Dimensions

Well diameter (mm)	Bore (mm)	Type	Output (kW)	Outer dimensions (mm)				Lead wire (mm ²)	Approx. mass (kg)	Fig.	
				L	Lp	Lm	Maximum diameter				
150	50	50A-MSUS6-52.2-5	2.2	1139	760	379	φ135	2	39	1	
		50A-MSUS6-52.7-6	2.7	1391	820	571	φ135	2	44		
		50A-MSUS6-53.7-8	3.7	1512	941	571	φ135	2	47		
		50A-MSUS6-55.5-11	5.5	1791	1155	636	φ142	8	78	2	
		50A-MSUS6-57.5-15	7.5	2098	1397	701	φ142	8	89		
		50A-MSUS6-511-22	11	2646	1880	766	φ142	8	112		
	65	65A-MSUS6-52.2-5	2.2	1134	755	379	φ141	2	39	4	
		65A-MSUS6-52.7-6	2.7	1386	815	571	φ141	2	44		
		65A-MSUS6-53.7-8	3.7	1507	936	571	φ141	2	47		
		65A-MSUS6-55.5-11	5.5	1786	1150	636	φ142	8	78	5	
		65A-MSUS6-57.5-15	7.5	2093	1392	701	φ142	8	89		
		65A-MSUS6-511-22	11	2646	1880	766	φ143	8	115		
		65B-MSUS6-515-29	15	3134	2303	831	φ143	8	132	6	
		65B-MSUS6-52.2-3	2.2	1149	770	379	φ141	2	39		
		65B-MSUS6-52.7-4	2.7	1437	866	571	φ141	2	44		
		80	65B-MSUS6-53.7-5	3.7	1533	962	571	φ141	2	46	4
			65B-MSUS6-55.5-8	5.5	1919	1283	636	φ142	8	82	
			65B-MSUS6-57.5-10	7.5	2176	1475	701	φ142	8	91	
			65B-MSUS6-511-14	11	2704	1938	766	φ142	8	115	5
			65B-MSUS6-515-18	15	3153	2322	831	φ142	8	130	
			80B-MSUS6-53.7-5	3.7	1548	977	571	φ141	2	47	
		80	80B-MSUS6-55.5-8	5.5	1934	1298	636	φ142	8	83	4
			80B-MSUS6-57.5-10	7.5	2191	1490	701	φ142	8	92	
			80B-MSUS6-511-14	11	2789	2023	766	φ142	8	119	5
80B-MSUS6-515-18	15		3238	2407	831	φ142	8	135			

Well diameter 150mm / Pump bore 50 - 80mm Impeller made of SCS13

■ Assembly drawing

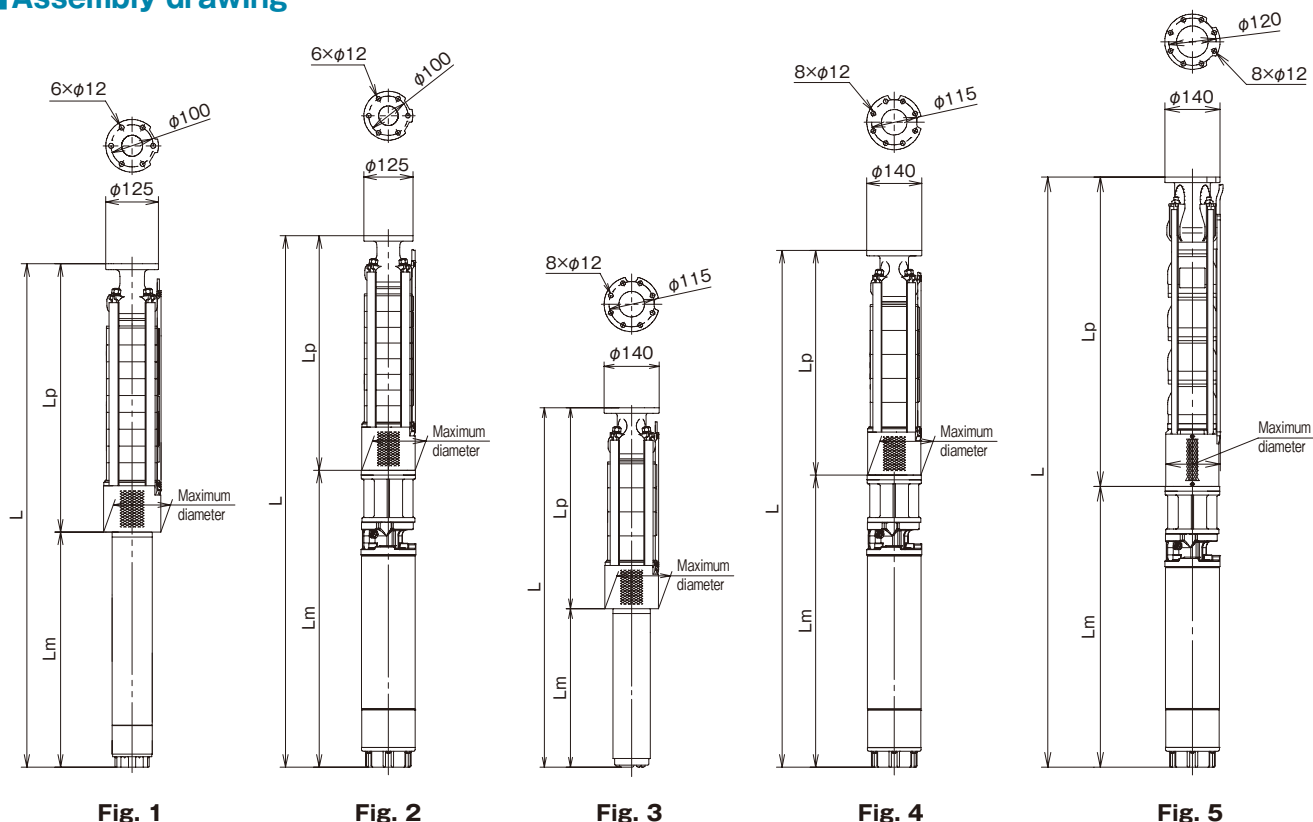

■ Dimensions

Well diameter (mm)	Bore (mm)	Type	Output (kW)	Outer dimensions (mm)				Lead wire (mm ²)	Approx. mass (kg)	Fig.
				L	Lp	Lm	Maximum diameter			
150	50	50MSUS6-51.9-5	1.9	852	473	379	φ139	2	32	1
		50MSUS6-52.2-6	2.2	892	513	379	φ139	2	33	
		50MSUS6-52.7-7	2.7	1124	553	571	φ139	2	42	
		50MSUS6-53.7-9	3.7	1204	633	571	φ139	2	45	
		50MSUS6-55.5-13	5.5	1554	918	636	φ139	8	81	
		50MSUS6-57.5-16	7.5	1739	1038	701	φ139	8	91	
	65	50MSUS6-57.5-19	7.5	1859	1158	701	φ139	8	96	2
		50MSUS6-511-24	11	2124	1358	766	φ142	8	109	
		65MSUS6-52.2-4	2.2	886	507	379	φ140	2	32	
		65MSUS6-52.7-5	2.7	1139	568	571	φ140	2	42	
		65MSUS6-53.7-6	3.7	1200	629	571	φ140	2	44	
		65MSUS6-55.5-9	5.5	1573	937	636	φ140	8	80	
	80	65MSUS6-57.5-12	7.5	1821	1120	701	φ140	8	91	4
		65MSUS6-511-15	11	2069	1303	766	φ142	8	104	
		65MSUS6-511-18	11	2252	1486	766	φ142	8	110	
		65MSUS6-515-21	15	2500	1669	831	φ142	8	123	
65MSUS6-515-25		15	2744	1913	831	φ142	8	140		
80MSUS6-53.7-4		3.7	1509	905	604	φ141	8	76		
80MSUS6-55.5-6		5.5	1761	1125	636	φ141	8	86		
80MSUS6-57.5-8		7.5	2046	1345	701	φ141	8	99		
80MSUS6-511-11	11	2591	1825	766	φ142	8	121	5		
80MSUS6-515-15	15	3096	2265	831	φ142	8	143			

Well diameter 200mm / Pump bore 80mm Impeller made of SUS304

■ Assembly drawing

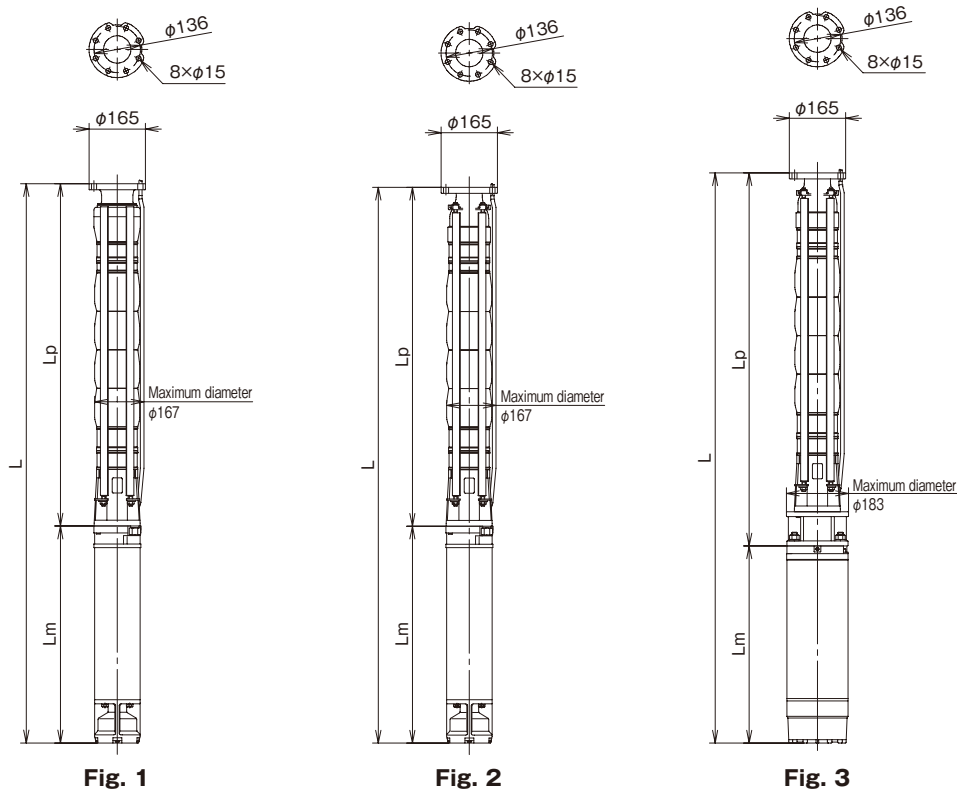

Fig. 1

Fig. 2

Fig. 3

■ Dimensions

Well diameter (mm)	Bore (mm)	Type	Output (kW)	Outer dimensions (mm)			Lead wire (mm ²)	Approx. mass (kg)	Fig.
				L	Lp	Lm			
200	80	80C-MSUS8-53.7-3	3.7	1508	904	604	8	73	1
		80C-MSUS8-55.5-5	5.5	1766	1130	636	8	80	
		80C-MSUS8-57.5-6	7.5	1944	1243	701	8	88	
		80C-MSUS8-511-9	11	2473	1707	766	8	106	
		80C-MSUS8-515-12	15	2877	2046	831	8	120	
		80C-MSUS8-518-14	18.5	3158	2262	896	8	135	2
		80C-MSUS8-522-16	22	3343	2575	768	5.5	174	3
		80C-MSUS8-526-19	26	4037	3039	998	8	212	
		80C-MSUS8-530-21	30	4263	3265	998	8	218	
80C-MSUS8-537-26	37	4893	3830	1063	14	246			

Well diameter 200mm / Pump bore 80 - 100mm Impeller made of SCS13

■ Assembly drawing

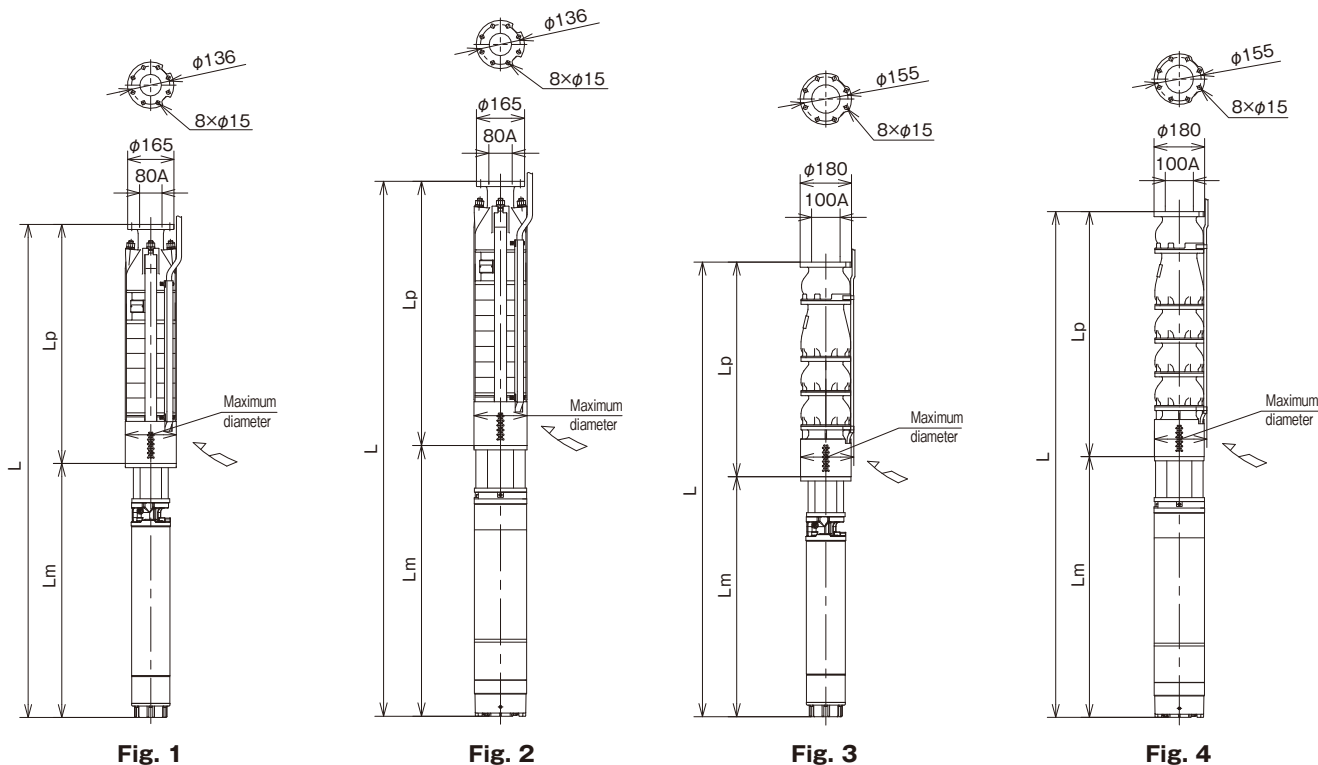

■ Dimensions

Well diameter (mm)	Bore (mm)	Type	Output (kW)	Outer dimensions (mm)				Lead wire (mm ²)	Approx. mass (kg)	Fig.
				L	Lp	Lm	Maximum diameter			
200	80	80MSUS8-53.7-2	3.7	1385	781	604	φ191	8	90	1
		80MSUS8-55.5-3	5.5	1470	834	636	φ191	8	103	
		80MSUS8-57.5-4	7.5	1588	887	701	φ191	8	105	
		80MSUS8-511-6	11	1759	993	766	φ191	8	120	
		80MSUS8-515-8	15	1930	1099	831	φ191	8	136	
		80MSUS8-518-10	18.5	2101	1205	896	φ191	8	149	
	80	80MSUS8-522-12	22	2099	1331	768	φ191	5.5	192	2
		80MSUS8-526-14	26	2435	1437	998	φ193	8	226	
	100	100MSUS8-53.7-1	3.7	1256	652	604	φ190	8	90	3
		100MSUS8-55.5-2	5.5	1408	772	636	φ190	8	102	
		100MSUS8-57.5-3	7.5	1593	892	701	φ190	8	116	
		100MSUS8-511-4	11	1778	1012	766	φ190	8	132	
		100MSUS8-515-5	15	1963	1132	831	φ190	8	148	
		100MSUS8-518-6	18.5	2148	1252	896	φ190	8	162	
100MSUS8-522-7		22	2160	1392	768	φ190	5.5	207		
100MSUS8-526-8		26	2630	1632	998	φ194	8	252		
100	100MSUS8-530-10	30	2870	1872	998	φ194	8	272	4	
	100MSUS8-537-12	37	3175	2112	1063	φ194	14	306		

Well diameter 75mm / Pump bore 25mm

■ Assembly drawing

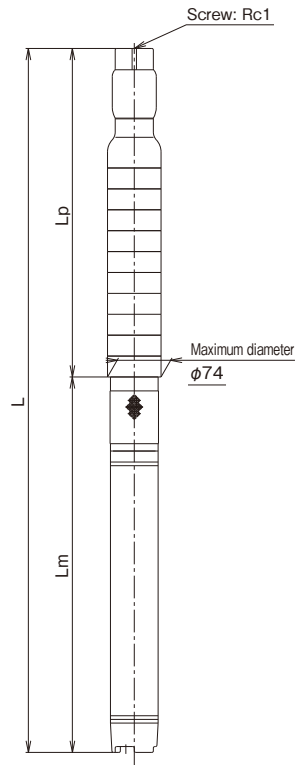

■ Dimensions

Well diameter (mm)	Bore (mm)	Type	Output (kW)	Outer dimensions (mm)			Approx. mass (kg)
				L	Lm	Lp	
75	25	25MSU3-5.4-16	0.4	1137	697	440	22
		25MSU3-5.75-30	0.75	1636	1096	540	30

Well diameter 125 - 150mm / Pump bore 40mm (25mm)

■ Assembly drawing

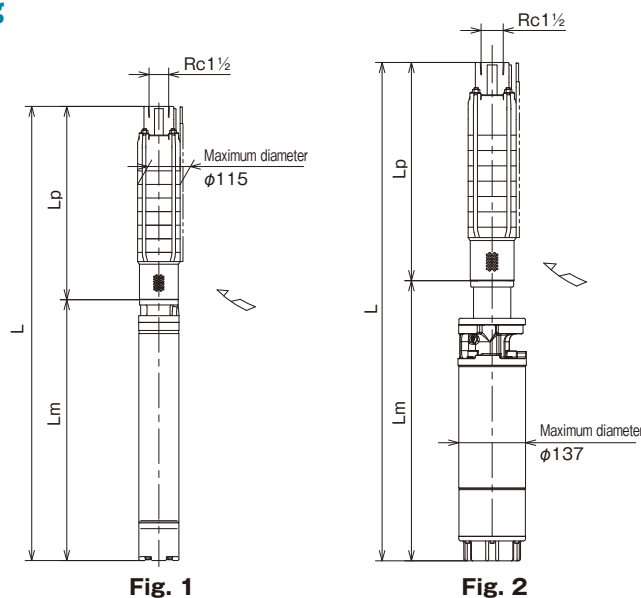

Fig. 1

Fig. 2

■ Dimensions

Well diameter (mm)	Bore (mm)	Type	Output (kW)	Outer dimensions (mm)			Lead wire (mm ²)	Approx. mass (kg)	Fig.
				L	Lp	Lm			
125	(25) 40	40MSU5-51.5-7	1.5	905	489	416	1.25	29	1
		40MSU5-52.2-11	2.2	1089	613	476	1.25	36	
		40MSU5-53.7-18	3.7	1386	830	556	1.25	47	
150	(25) 40	40MSU6-55.5-25	5.5	1725	1089	636	8	75	2
		40MSU6-57.5-35	7.5	2250	1549	701	8	95	

* Bore (25) is for regulated areas.

Well diameter 200mm / Pump bore 80 - 100mm

Assembly drawing

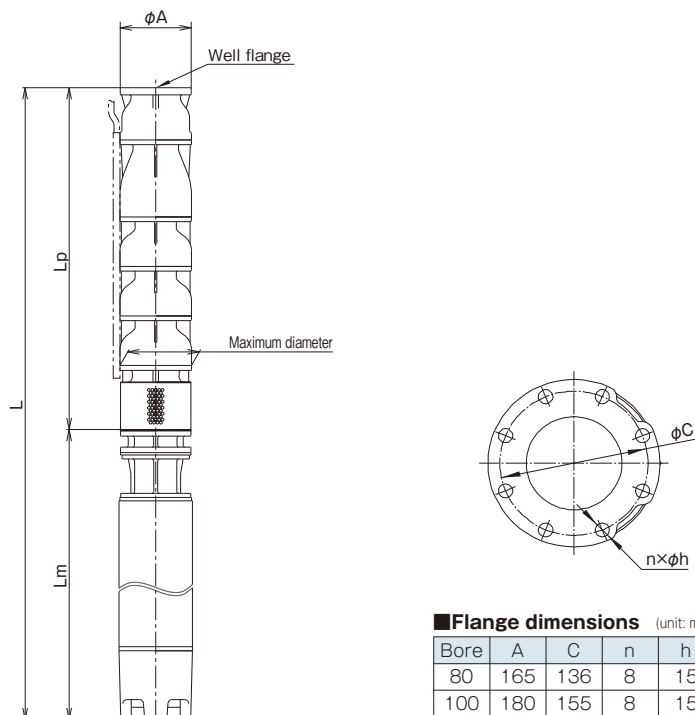

Flange dimensions (unit: mm)

Bore	A	C	n	h
80	165	136	8	15
100	180	155	8	15

Dimensions

Well diameter (mm)	Bore (mm)	Type	Output (kW)	Outer dimensions (mm)				Lead wire (mm ²)	Approx. mass (kg)
				L	Lp	Lm	Maximum diameter		
200	80	80MSU8-53.7-2	3.7	1355	751	604	φ189	8	100
		80MSU8-55.5-3	5.5	1507	871	636	φ189	8	119
		80MSU8-57.5-4	7.5	1692	991	701	φ189	8	135
		80MSU8-511-6	11	1997	1231	766	φ189	8	161
		80MSU8-515-8	15	2422	1591	831	φ189	8	197
		80MSU8-518-10	18.5	2727	1831	896	φ189	8	225
		80MSU8-522-11	22	3012	1832	1180	φ189	8	315
		80MSU8-526-13	26	3402	2112	1290	φ189	8	347
	80MSU8-530-15	30	3642	2352	1290	φ189	8	370	
	100	100MSU8-53.7-1	3.7	1235	631	604	φ189	8	88
		100MSU8-55.5-2	5.5	1387	751	636	φ189	8	107
		100MSU8-57.5-2	7.5	1452	751	701	φ189	8	111
		100MSU8-57.5-3	7.5	1572	871	701	φ189	8	123
		100MSU8-511-3	11	1637	871	766	φ189	8	126
		100MSU8-511-4	11	1757	991	766	φ189	8	138
		100MSU8-515-4	15	1822	991	831	φ189	8	144
		100MSU8-515-5	15	1942	1111	831	φ189	8	155
		100MSU8-518-5	18.5	2007	1111	896	φ189	8	161
		100MSU8-518-6	18.5	2127	1231	896	φ189	8	173
		100MSU8-522-6	22	2292	1112	1180	φ189	8	252
		100MSU8-522-7	22	2412	1232	1180	φ189	8	263
		100MSU8-526-7	26	2522	1232	1290	φ189	8	278
		100MSU8-526-8	26	2762	1472	1290	φ189	8	297
		100MSU8-530-8	30	2762	1472	1290	φ189	8	297
		100MSU8-530-10	30	3002	1712	1290	φ189	8	319
		100MSU8-537-10	37	3062	1712	1350	φ193	14	334
		100MSU8-537-13	37	3462	2112	1350	φ193	14	365

Well diameter (mm)	Bore (mm)	Type	Outer dimensions (mm)				Approx. mass (kg)
			L	Lm	LP	Maximum diameter	
200	100	100MSU8-57.5-2B	Please contact us.				
		100MSU8-511-3B					
		100MSU8-515-4B					
		100MSU8-518-5B					
		100MSU8-522-6B					
		100MSU8-526-6B					
		100MSU8-530-7B					
100MSU8-537-9B							

Well diameter 250 - 400mm / Pump bore 100 - 250mm

■ Assembly drawing

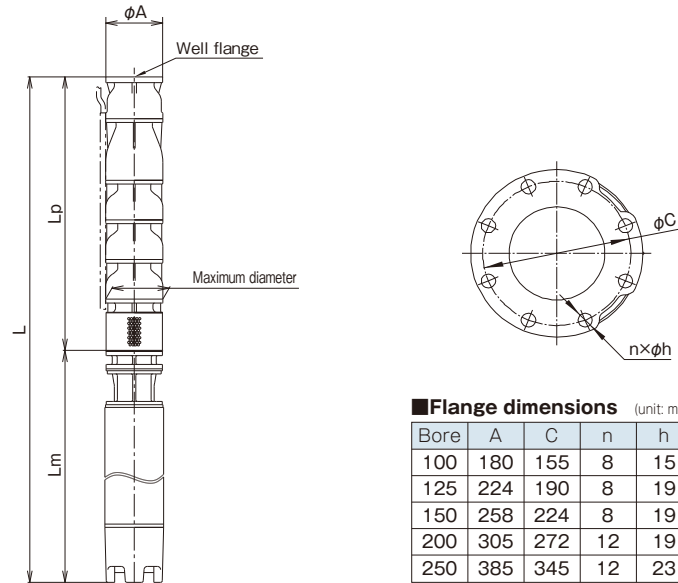

■ Flange dimensions (unit: mm)

Bore	A	C	n	h
100	180	155	8	15
125	224	190	8	19
150	258	224	8	19
200	305	272	12	19
250	385	345	12	23

■ Dimensions

● For 250mm well (10B)

Well diameter (mm)	Bore (mm)	Type	Output (kW)	Outer dimensions (mm)				Lead wire (mm ²)	Approx. mass (kg)
				L	Lp	Lm	Maximum diameter		
250	100	100MSU10-545-12	45	3472	2070	1402	φ216	22	448
		125MSU10-57.5-1	7.5	1365	664	701	φ240	8	123
	125	125MSU10-511-1	11	1430	664	766	φ240	8	130
		125MSU10-511-2	11	1575	809	766	φ240	8	150
		125MSU10-515-2	15	1640	809	831	φ240	8	156
		125MSU10-518-2	18.5	1705	809	896	φ240	8	162
		125MSU10-522-3	22	2085	905	1180	φ240	8	266
		125MSU10-526-3	26	2195	905	1290	φ245	8	285
		125MSU10-530-4	30	2340	1050	1290	φ245	8	305
		125MSU10-537-4	37	2400	1050	1350	φ245	14	320
125MSU10-545-5	45	2517	1115	1402	φ245	22	411		
125MSU10-555-6	55	2732	1260	1472	φ245	22	446		

● For 300mm well (12B)

Well diameter (mm)	Bore (mm)	Type	Output (kW)	Outer dimensions (mm)				Lead wire (mm ²)	Approx. mass (kg)
				L	Lp	Lm	Maximum diameter		
300	150	150MSU12-511-1	11	1602	836	766	φ275	8	155
		150MSU12-515-1	15	1667	836	831	φ275	8	173
		150MSU12-518-1	18.5	1732	836	896	φ275	8	214
		150MSU12-522-2	22	2147	967	1180	φ275	8	305
		150MSU12-526-2	26	2257	967	1290	φ275	8	305
		150MSU12-530-2	30	2257	967	1290	φ275	8	320
		150MSU12-537-2	37	2317	967	1350	φ280	14	356
		150MSU12-545-3	45	2324	1067	1257	φ288	22	434
		150MSU12-555-3	55	2389	1067	1322	φ288	22	496
		150MSU12-575-4	75	2839	1327	1512	φ288	38	660

● For 350mm well (14B)

Well diameter (mm)	Bore (mm)	Type	Output (kW)	Outer dimensions (mm)				Lead wire (mm ²)	Approx. mass (kg)
				L	Lp	Lm	Maximum diameter		
350	200	200MSU14-530-1	30	2220	930	1290	φ322	8	338
		200MSU14-537-1	37	2280	930	1350	φ322	14	358
		200MSU14-545-2	45	2327	1070	1257	φ322	22	463
		200MSU14-555-2	55	2392	1070	1322	φ322	22	525
		200MSU14-575-2	75	2582	1070	1512	φ322	38	650

● For 400mm well (16B)

Well diameter (mm)	Bore (mm)	Type	Output (kW)	Outer dimensions (mm)				Lead wire (mm ²)	Approx. mass (kg)
				L	Lp	Lm	Maximum diameter		
400	250	250MSU16-522-1	22	2235	985	1250	φ387	Please contact us.	
		250MSU16-530-2	30	2500	1250	1250	φ387		
		250MSU16-537-2	37	2770	1250	1520	φ387		
		250MSU16-545-2	45	2770	1250	1520	φ387		
		250MSU16-545-3	45	3035	1515	1520	φ387		
		250MSU16-555-3	55	3285	1515	1770	φ387		
		250MSU16-575-4	75	3210	1780	1430	φ387		

Well diameter 100mm / Pump bore 25 - 50mm

Assembly drawing

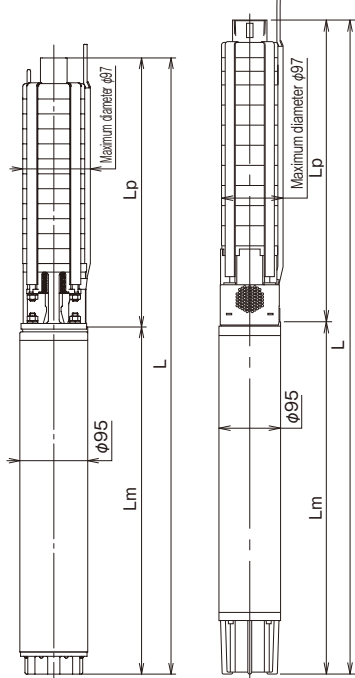

Fig. 1

Fig. 2

Dimensions

Well diameter (mm)	Bore (mm)	Type	Output (kW)	Discharge size	Outer dimensions (mm)			Approx. mass (kg)	Fig.
					L	Lp	Lm		
100	25	25MSUH4-5.6-11	0.6	Rc1	928	441	487	22	1
		25MSUH4-5.75-13	0.75	Rc1	970	483	487	22	
		25MSUH4-51.1-19	1.1	Rc1	1117	630	487	24	
		25MSUH4-51.5-26	1.5	Rc1	1264	777	487	25	
		25MSUH4-52.2-38	2.2	Rc1	1556	1050	506	30	
		25MSUH4-52.2-44	2.2	Rc1	1682	1176	506	32	
	32	32MSUH4-5.75-10	0.75	Rc1¼	907	420	487	22	1
		32MSUH4-51.1-15	1.1	Rc1¼	1012	525	487	23	
		32MSUH4-51.5-20	1.5	Rc1¼	1138	651	487	24	
		32MSUH4-52.2-30	2.2	Rc1¼	1367	861	506	26	
		32MSUH4-53.7-36	3.7	Rc1¼	1592	1008	584	34	
		32MSUH4-53.7-50	3.7	Rc1¼	1907	1323	584	37	
	40	40MSUH4-5.75-5	0.75	Rc1½	890	403	487	22	2
		40MSUH4-51.1-7	1.1	Rc1½	952	465	487	22	
		40MSUH4-51.5-10	1.5	Rc1½	1045	558	487	23	
		40MSUH4-52.2-14	2.2	Rc1½	1219	713	506	25	
		40MSUH4-53.7-18	3.7	Rc1½	1421	837	584	30	
		40MSUH4-53.7-23	3.7	Rc1½	1607	1023	584	32	
	50	50MSUH4-5.75-3	0.75	Rc2	874	387	487	22	2
		50MSUH4-51.1-5	1.1	Rc2	964	477	487	23	
50MSUH4-51.5-7		1.5	Rc2	1054	567	487	24		
50MSUH4-52.2-10		2.2	Rc2	1243	737	506	26		
50MSUH4-53.7-13		3.7	Rc2	1456	872	584	31		
50MSUH4-53.7-17		3.7	Rc2	1671	1087	584	33		

Well diameter 150mm / Pump bore 50 - 80mm

Assembly drawing

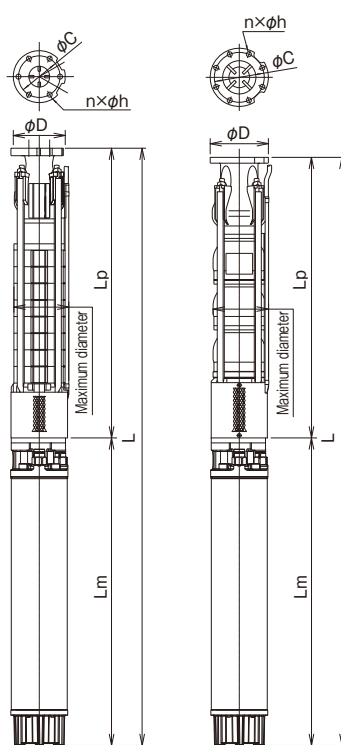

Fig. 3

Fig. 4

Dimensions

Well diameter (mm)	Bore (mm)	Type	Output (kW)	Discharge size	Outer dimensions (mm)			Approx. mass (kg)	Fig.
					L	Lp	Lm		
150	50	50MSUH6-53.7-9	3.7	1217	633	584	φ139	46	3
		50MSUH6-55.5-13	5.5	1654	918	736	φ139	87	
		50MSUH6-57.5-16	7.5	1839	1038	801	φ139	99	
		50MSUH6-57.5-19	7.5	1959	1158	801	φ139	104	
		50MSUH6-511-24	11	2224	1358	866	φ142	119	
		65MSUH6-53.7-6	3.7	1213	629	584	φ140	46	
	65	65MSUH6-55.5-9	5.5	1673	937	736	φ140	86	3
		65MSUH6-57.5-12	7.5	1921	1120	801	φ140	99	
		65MSUH6-511-15	11	2169	1303	866	φ142	114	
		65MSUH6-511-18	11	2352	1486	866	φ142	120	
		65MSUH6-515-21	15	2600	1669	931	φ142	139	
		65MSUH6-515-25	15	2844	1913	931	φ142	156	
	80	80MSUH6-53.7-4	3.7	1576	905	671	φ141	77	4
		80MSUH6-55.5-6	5.5	1861	1125	736	φ141	92	
		80MSUH6-57.5-8	7.5	2146	1345	801	φ141	107	
		80MSUH6-511-11	11	2691	1825	866	φ142	131	
		80MSUH6-515-15	15	3196	2265	931	φ142	153	

Flange dimensions

Bore	A	C	n	h	Fig.
50	125	100	6	12	3
65	140	115	8	12	3
80	140	120	8	12	4

(unit: mm)

Combination of pump and control method

Example of installation of a pressure tank and pressure switch control, or water receiving tank liquid level control (control panel method)

3-phase, 200V, 0.6 - 3.7kW

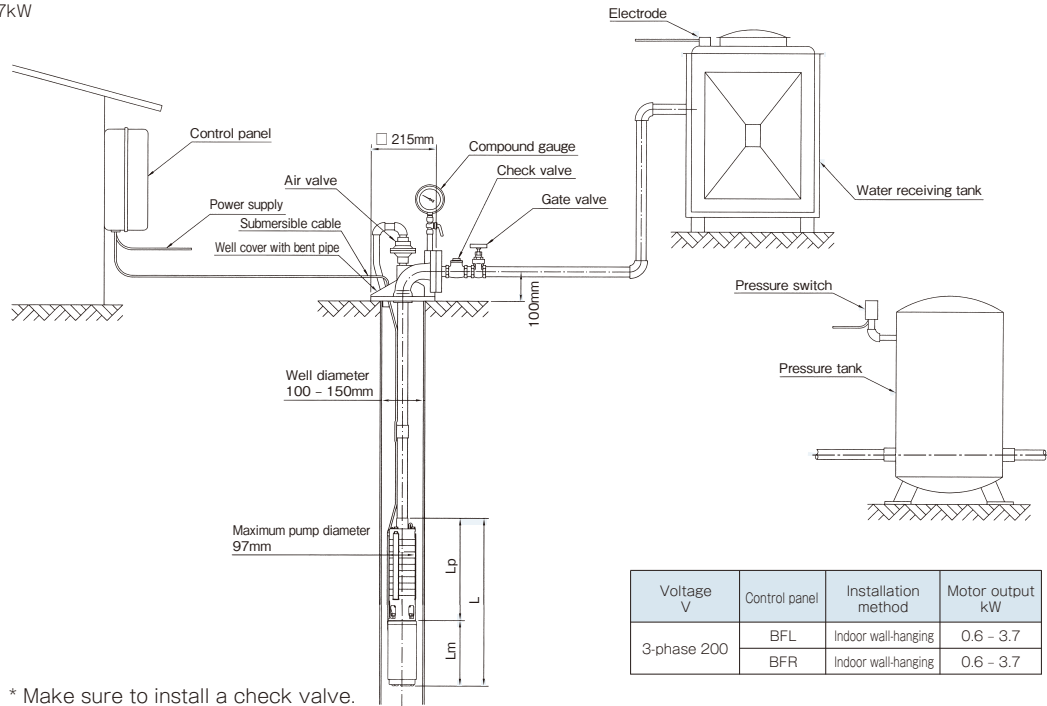

Combination of pump and aboveground section

Pump installation position

- Install as far above the well strainer as possible.
- Avoid agreement between the well strainer and pump strainer where possible. If they are in agreement, sand will be taken in, causing pump wear, seizing, or well collapse.
- Keep at least 10m from the well bottom. Otherwise, the motor will be filled with sand, causing failure.

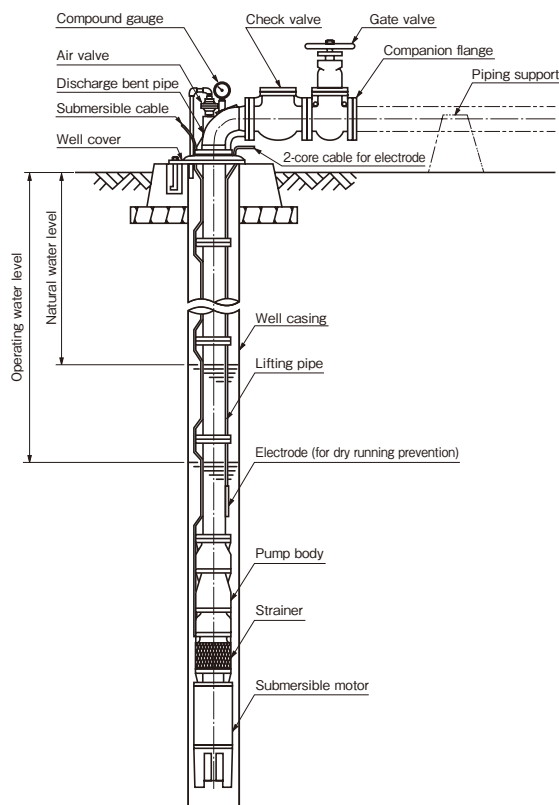

Installation and flange dimensions (threaded type)

Assembly drawing

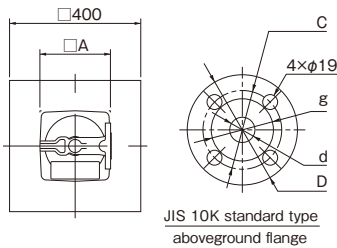
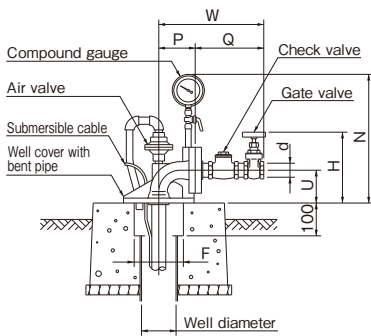

Dimensions

(Unit: mm)

Bore	Lifting pipe connection	Max. well diameter applicable for well cover	Flange dimensions				Aboveground well cover dimensions								Approx. mass of aboveground section (kg)
			D	C	g	d	A	W	P	Q	N	H	U	F	
25	Threaded type	125	140	100	79	Rc1	215	293	110	183	380	205	100	150	15
32	Threaded type	125	140	100	79	Rc1½	215	338	110	228	380	217	100	150	14
40	Threaded type	125	140	105	79	Rc1½	215	348	110	238	380	233	100	150	15
50	Threaded type	125	155	120	100	Rc2	220	390	112	278	350	277	115	150	18

Installation and flange dimensions (flange type: JIS 10K standard type)*1

Assembly drawing

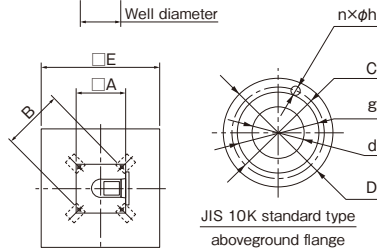
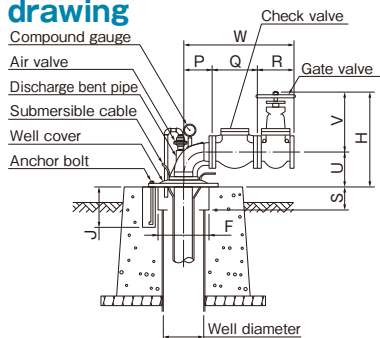

Dimensions

(Unit: mm)

Bore	Pump	Max. well diameter applicable for well cover	Flange dimensions					Aboveground well cover dimensions							Basic dimensions					Approx. mass of aboveground section (kg)	
			d	g	C	D	n×h	P	R	Q	W	U	V	H	A	F	B	J	E		S
50	50MSUS6	200	50	100	120	155	4×19	130	180	200	510	170	276	446	250	210	300	200	550	100	49
	50A-MSUS6																				
65	65MSUS6	200	65	120	140	175	4×19	150	190	220	560	190	302	492	250	210	300	200	550	100	52
	65A-MSUS6																				
	65B-MSUS6																				
80	80MSUS6	200	80	130	150	185	8×19	180	200	240	620	225	332	557	265	250	280	260	650	150	83
	80B-MSUS6																				
	80MSU(S)8	250	80	130	150	185	8×19	180	200	240	620	225	332	557	310	250	380	260	650	150	83
100	100MSU(S)8	250	100	155	175	210	8×19	180	230	290	700	225	384	609	310	250	380	260	650	150	107
	100MSU10																				
125	125MSU10	300	125	185	210	250	8×23	200	250	360	810	245	435	680	350	320	430	300	750	150	155
150	150MSU12	350	150	215	240	280	8×23	220	270	410	900	270	497	767	400	350	500	300	800	200	200
200	200MSU14	400	200	265	290	330	12×23	300	290	500	1090	350	608	958	500	410	630	300	900	200	345

*1 Flanges of JIS 10K standard type and thin type are the same in discharge bent pipe but different in gate valve and check valve.

Installation and flange dimensions (flange type: JIS 10K thin type)^{※1}

■ Assembly drawing

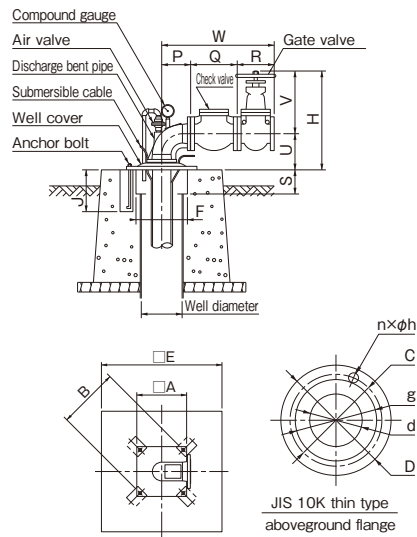

■ Dimensions

(Unit: mm)

Bore	Pump	Max. well diameter applicable for well cover	Flange dimensions					Aboveground well cover dimensions							Basic dimensions					Approx. mass of aboveground section (kg)	
			d	g	C	D	n x h	P	R	Q	W	U	V	H	A	F	B	J	E		S
50	50MSUS6	200	50	100	120	155	4 x 15	130	150	160	440	170	235	405	250	210	300	200	550	100	44.5
	50A-MSUS6																				
65	65MSUS6	200	65	120	140	175	4 x 15	150	160	175	485	190	266	456	250	210	300	200	550	100	47
	65A-MSUS6																				
80	80MSUS6	200	80	130	150	185	8 x 15	180	175	185	540	225	293	518	265	250	280	260	650	150	72
	80B-MSUS6																				
100	80MSU(S)8	250	80	130	150	185	8 x 15	180	175	185	540	225	293	518	310	250	380	260	650	150	72
	80C-MSUS8																				
100	100MSU(S)8	250	100	155	175	210	8 x 15	180	200	230	610	225	360	585	310	250	380	260	650	150	94
	100MSU10																				
125	125MSU10	300	125	185	210	250	8 x 19	200	225	255	680	245	406	651	350	320	430	300	750	150	119.5
150	150MSU12	350	150	215	240	280	8 x 19	220	250	290	760	270	453	723	400	350	500	300	800	200	158

※1 Flanges of JIS 10K standard type and thin type are the same in discharge bent pipe but different in gate valve and check valve.

Assembly drawing

● Threaded type

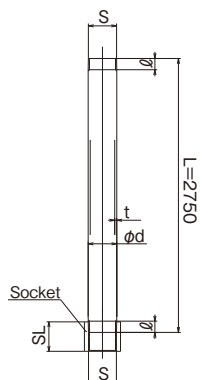

● Flange type

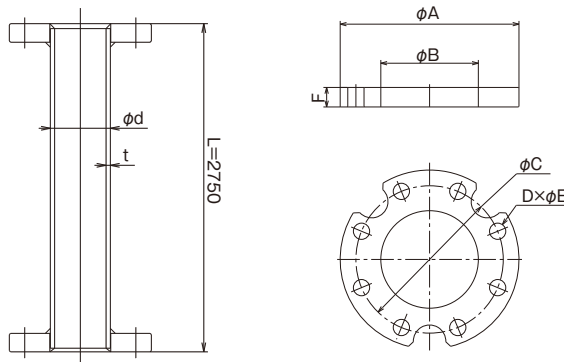

Dimensions

● Threaded type

(Unit: mm)

Bore	Lifting pipe				Socket		Mass (including socket) kg
	S	ℓ	t	d	S	SL	
25	Rc1	16.79	3.2	34.0	Rc1	45	6.9
32	Rc1¼	19.1	3.5	42.7	Rc1¼	50	9.6
40	Rc1½	19.1	3.5	48.6	Rc1½	55	11.0
50	Rc2	23.4	3.8	60.5	Rc2	60	15.1
65	Rc2½	26.6	4.2	76.3	Rc2½	70	22.0
80	Rc3	29.8	4.2	89.1	Rc3	75	25.3
100	Rc4	35.8	4.5	114.3	Rc4	85	35.0

● Flange type

(Unit: mm)

Min. well diameter applicable for pump	Min. well diameter applicable for lifting pipe	Bore	Pump type	Lifting pipe flange type	Lifting pipe		Lifting pipe flange						Applicable bolt size	Lifting pipe mass kg
					d	t	A	B	C	D	E	F		
100	100	32	32MSUS4*1	RF32-04	42.7	3.5	95	43.2	75	4	12	12	M10×40	9.5
125	150	40	40MSUS4*1	RF40-07	48.6	3.5	115	49.1	90	6	12	14	M10×45	11
40MSU5*1														
40MSU6*1														
150	150	50	50MSUS4*1	RF50-04	60.5	3.8	125	61.1	100	6	12	14	M10×45	17.5
50MSUS6														
50A-MSUS6														
100	150	65	65MSUS6	RF65-13	76.3	4.2	140	77.1	115	8	12	14	M10×45	24.5
65A-MSUS6														
65B-MSUS6														
200	200	80	80MSUS6	RF80-41	89.1	4.2	140	90	120	8	12	19	M10×55	29.0
80B-MSUS6														
80MSU(S)8														
250	250	100	80C-MSUS8	RF80-24	89.1	4.2	165	90	136	8	15	18	M12×55	29.2
100MSU(S)8														
100MSU10														
300	300	125	125MSU10	RF100-07	114.3	4.5	180	115.4	155	8	15	18	M12×55	37.0
350	350	150	150MSU12	RF125-05	139.8	4.5	224	141.2	190	8	19	20	M16×65	47.0
		200	200MSU14	RF200-03	218	5.8	305	218	272	12	19	22	M16×70	93.0

*Connecting pipe is used because the pump is threaded type.

■ Allowable length

● Applicable standards

(JISB8324-compliant)

- Aboveground section: Within 3m
- Ambient temperature: 30°C or less
- Allowable current: Rated current of motor × 110%
- Voltage drop: 5% of rating or less
- Aerial installation in conduit

* Values in the table are obtained based on the conditions of the JIS Standards. Slight extension may be possible depending on the conditions of use.

● Cautions

1. If the selected cable size is too thick, it may not fit into the well. In such a case, please contact us.
2. Cable sizes in the table are for up to the conduit and terminal box, etc. Do not apply them to aboveground wiring.
3. Do not coil any excess cable above ground.

● Stainless steel MSUS model, for 200V

Applicable pump	Frame number	Starting method	Output (kW)	Allowable cable length (m)																						
				Cable size (mm ²)																						
				Flat 3-core EVCT								Flat 3-core CVCT														
				1.25	2	3.5	5.5	8	14	22	30	38	50	60												
25MSUS4 32MSUS4 40MSUS4 50MSUS4	M4	Direct-on-Line	0.6	140	217																					
			0.75	105	163	305																				
			1.1	80	124	232	361																			
			1.5	59	92	172	268	377																		
			1.9	50	78	146	228	321																		
			2.2	40	62	116	181	255																		
			2.7	29	45	85	133	187	329																	
3.7		36	67	104	147	259																				
50MSUS6 65MSUS6	M4	Direct-on-Line	1.9	50	78	146	228	321																		
			2.2	40	62	116	181	255																		
			2.7	29	45	85	133	187	329																	
	M6	Direct-on-Line	3.7		36	67	104	147	259																	
			5.5			46	71	101	177	278	375															
			7.5				56	79	139	218	294	371														
			11				36	57	80	141	220	298	376													
M6	Star-delta	15					61	107	168	227	286	364														
		3.7			36	68	106	150	264																	
		5.5				46	71	101	177	278	375															
		7.5					56	79	139	218	294	371														
80MSUS6 80C-MSUS8 80MSUS8 100MSUS8	M6	Direct-on-Line	11				36	57	80	141	220	298	376													
			15						61	107	168	227	286	364												
			18.5								88	138	186	235	299	374										
	M8	Star-delta	22							77	121	163	206	262	328											
			26								64	101	136	171	219	274										
			30									56	87	118	149	190	237									
			37										71	96	121	155	194									

●Stainless steel MSUS model, for 400V

Applicable pump	Frame number	Starting method	Output (kW)	Allowable cable length (m)												
				Cable size (mm ²)												
				Flat 3-core EVCT						Flat 3-core CVCT						
				1.25	2	3.5	5.5	8	14	22	30	38	50	60		
25MSUS4 32MSUS4 40MSUS4 50MSUS4	M4	Direct-on-Line	0.75	422												
			1.1	321	497											
			1.5	238	369											
			2.2	161	249	465										
			3.7	93	144	269	420									
50MSUS6 65MSUS6	M4	Direct-on-Line	2.2	161	249	465										
			3.7	93	144	269	420									
50A-MSUS6 65A-MSUS6 65B-MSUS6 80B-MSUS6	M6	Direct-on-Line	5.5	63	98	184	287	404								
			7.5		77	144	225	317								
		Star-delta	11	50	78	146	228	321								
			15		59	111	173	244	430							
80MSUS6 80C-MSUS8 80MSUS8 100MSUS8	M6	Direct-on-Line	3.7	94	146	273	426									
			5.5	63	98	184	287	404								
		Star-delta	7.5		77	144	225	317								
			11	50	78	146	228	321								
	M8	Star-delta	15		59	111	173	244	430							
			18.5			91	142	200	353							
		Star-delta	22			80	125	176	309	484						
			26			66	104	146	258	404						
		30			90	127	224	350	473							
		37				104	182	286	386	486						

※ The above table is not applicable to outputs of 0.6kW, 1.9kW and 2.7kW.

●Cast iron MSU model, for 200V

Applicable pump	Frame number	Starting method	Output (kW)	Allowable cable length (m)											
				Cable size (mm ²)											
				Flat 3-core EVCT						Flat 3-core CVCT					
				1.25	2	3.5	5.5	8	14	22	30	38	50	60	
25MSU3	M3	Direct-on-Line	0.4	173	269										
			0.75	92	143	267									
40MSU5	M4	Direct-on-Line	1.5	53	82	153	239	337							
			2.2	38	59	111	174	245							
			3.7		36	67	104	147	259						
40MSU6 80MSU8 100MSU8 100MSU10 125MSU10	M6	Direct-on-Line	3.7		36	68	106	150	264						
			5.5			46	71	101	177	278	375				
		Star-delta	7.5				56	79	139	218	294	371			
			11			37	58	82	144	226	305	385			
			15					61	107	168	227	286	364		
	M8	Star-delta	18.5						88	138	186	235	299	374	
			22						73	114	155	195	249	311	
		Star-delta	26						65	102	137	173	221	277	
			30							88	119	150	191	239	
			37							72	97	123	156	196	
M10	Star-delta	45									100	128	160		
		55									78	100	125		
150MSU12 200MSU14	M6	Star-delta	11			37	58	82	144	226	305	385			
			15					61	107	168	227	286	364		
		18.5							88	138	186	235	299	374	
	M8	Star-delta	22						73	114	155	195	249	311	
			26						65	102	137	173	221	277	
		Star-delta	30							88	119	150	191	239	
			37							72	97	123	156	196	
			45								82	104	133	166	
M12	Star-delta	55									85	108	136		
		75											101		

●Cast iron MSU model, for 400V

Applicable pump	Frame number	Starting method	Output (kW)	Allowable cable length (m)												
				Cable size (mm ²)												
				Flat 3-core EVCT						Flat 3-core CVCT						
1.25	2	3.5	5.5	8	14	22	30	38	50	60						
25MSU3	M3	Direct-on-Line	0.4	695												
			0.75	371												
40MSU5	M4	Direct-on-Line	1.5	213	330											
			2.2	154	239	447										
			3.7	93	144	269	419									
40MSU6 80MSU8 100MSU10 100MSU10 125MSU10	M6	Direct-on-Line	3.7	94	146	273	426									
			5.5	63	98	184	287	404								
			7.5		77	144	225	317								
		Star-delta	11	52	80	150	233	329								
			15		59	111	173	244	430							
			18.5			91	142	200	353							
	M8	Star-delta	22			76	118	167	293	459						
			26				105	148	261	408						
			30				91	128	226	353	477					
		M10	Star-delta	37				105	184	289	390	492				
				45					151	237	320	403				
				55					118	185	250	315	402			
150MSU12 200MSU14	M6	Star-delta	11	52	80	150	233	329								
			15		59	111	173	244	430							
			18.5			91	142	200	353							
		M8	Star-delta	22			76	118	167	293	459					
				26				105	148	261	408					
				30				91	128	226	353	477				
	M12	Star-delta	37				105	184	289	390	492					
			45					157	245	331	418					
			55					128	200	271	341	435				
								149	202	254	324	406				

●MSUH model for hot spring, for 3-phase 200V (Unit: m)

Type	Motor output (kW)	Cable size (mm ²)	Ambient temperature (°C)		
			40	60	75
M4	1.5	2	84	78	74
		3.5	159	148	141
		5.5	244	227	216
	2.2	2	62	57	55
		3.5	115	107	102
		5.5	178	166	158
		8	252	234	223
	3.7	2	37	—	—
		3.5	68	65	—
		5.5	106	99	94
		8	149	139	132
		14	262	244	232

Numbers in the table show the values of CVCT-F (flat 3-core).

(Unit: m)

Type	Motor output (kW)	Cable size (mm ²)	Ambient temperature (°C)		
			40	60	75
M6	3.7	8	149	139	132
		14	262	244	232
		22	400	385	365
	5.5	8	105	100	95
		14	180	170	165
		22	285	265	255
		30	380	360	340
	7.5	8	80	75	70
		14	135	130	125
		22	210	200	190
		30	285	270	255
	11*	8	85	80	75
		14	145	135	125
		22	220	210	195
	15*	30	300	280	265
		8	60	60	—
		14	105	100	95
		22	165	155	145
		30	220	210	195

* For 11kW or more, allowable lengths in the case of star-delta start are shown.

■ Structural drawing

● Structural drawing

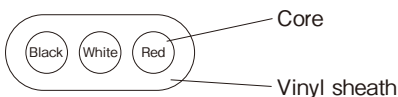

● Core

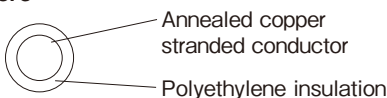

■ Outer dimensions and specifications

Cable type	Conductor		Finished outside diameter	Conductor resistance (20°C) Ω/km	Allowable current (30°C) A	Approx. mass kg/km
	Nominal cross-sectional area (mm ²)	Outside diameter (mm)	Short diameter x Long diameter (mm)			
EVCT-F	1.25	1.5	6.5±0.3×13.0±0.3	14.7	14	120
	2	1.8	7.0±0.3×14.0±0.3	9.50	19	150
	3.5	2.5	7.7±0.3×16.0±0.3	5.09	28	220
	5.5	3.1	9.1±0.3×19.5±0.3	3.27	36	325
	8	3.7	10.5±0.3×22.5±0.3	2.32	44	440
	14	5.1	12.5±0.3×28.5±0.3	1.32	62	720
	22	7.0	15.5±0.3×36.0±0.3	0.844	83	1120
CVCT-F	30	8.1	17.0±0.3×39.5±0.3	0.625	98	1410
	38	9.1	17.1±1.0×40.1±1.6	0.496	149	1630

■ Handling precautions

- Avoid piling up cables or using them when they are coiled.
- Do not expose cables to direct sunlight.
- Always keep cables in a well-ventilated condition.

For melting snow, a deep well submersible pump, snowfall detector, and control panel are available as a set. Each part has a structure superior in reliability, safety and durability.

Applications

- Melting of snow on roads, roofs, parking lots, etc.

Features

- Snowfall is automatically detected and the deep well submersible pump is automatically operated.
- The snow receiving plate is reliably actuated by snowfall and air temperature.
- Due to the automatic operation, initial snowfall is taken precisely, and when it stops snowing, the operation is finished after a certain period of time of remaining snow treatment to prevent loss of groundwater.
- There is no need for storage in summer.

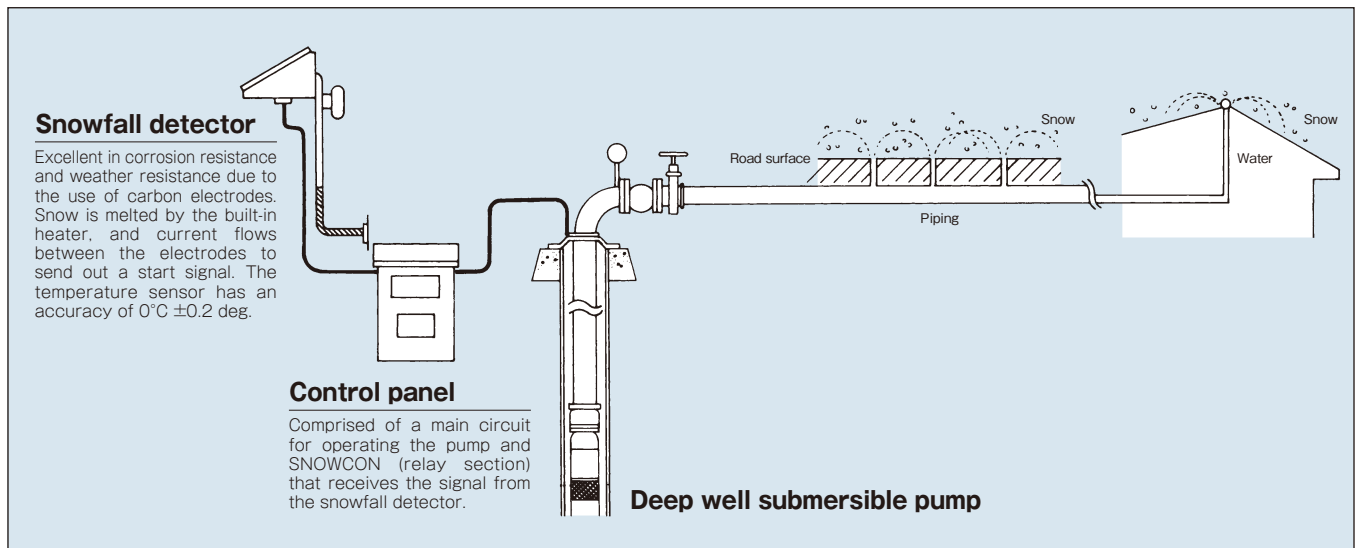
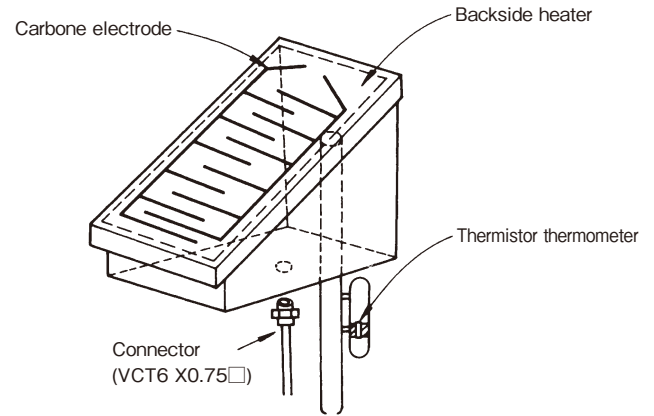

■ For well diameter 100mm

Material of wetted parts	Well diameter (mm)	Nominal pump diameter (mm)	Output (kW)	Number of stages	New type	Conventional MSUS series
Stainless steel	100	25	0.6	10	25MSUS4-5.6-10A	25MSUS4-5.6-11
			0.75	12	25MSUS4-5.75-12A	25MSUS4-5.75-13
			1.1	18	25MSUS4-51.1-18A	25MSUS4-51.1-19
			1.5	25	25MSUS4-51.5-25A	25MSUS4-51.5-26
			2.2	33	25MSUS4-52.2-33A	25MSUS4-51.9-38 25MSUS4-52.2-44
		32	0.75	9	32MSUS4-5.75-9A	32MSUS4-5.75-10
			1.1	13	32MSUS4-51.1-13A	32MSUS4-51.1-15 32MSUS4-51.5-13
			1.5	18	32MSUS4-51.5-18A	32MSUS4-51.5-15 32MSUS4-51.5-18
			2.2	26	32MSUS4-52.2-26A	32MSUS4-51.5-20 32MSUS4-51.9-25 32MSUS4-52.2-30
			3.7	40	32MSUS4-53.7-40A	32MSUS4-52.7-36 32MSUS4-53.7-50
			40	0.75	5	40MSUS4-5.75-5A
		1.1		8	40MSUS4-51.1-8A	40MSUS4-51.1-7
		1.5		11	40MSUS4-51.5-11A	40MSUS4-51.5-10
		1.9		13	40MSUS4-51.9-13A	40MSUS4-51.9-12
		2.2		15	40MSUS4-52.2-15A	40MSUS4-52.2-14
		2.7		19	40MSUS4-52.7-19A	40MSUS4-52.7-16 40MSUS4-53.7-18 40MSUS4-53.7-23
		3.7	25	40MSUS4-53.7-25A		

● For well regulation areas

Material of wetted parts	Well diameter (mm)	Nominal pump diameter (mm)	Output (kW)	Number of stages	New type	Conventional MSUS series
Stainless steel	100	25	0.75	9	25MSUS4-5.75-9A	25MSUS4-5.75-10
			1.1	13	25MSUS4-51.1-13A	25MSUS4-51.1-15 25MSUS4-51.5-13 25MSUS4-51.5-15
			1.5	18	25MSUS4-51.5-18A	25MSUS4-51.5-18 25MSUS4-51.5-20
			2.2	26	25MSUS4-52.2-26A	25MSUS4-51.9-25 25MSUS4-52.2-30
			3.7	40	25MSUS4-53.7-40A	25MSUS4-52.7-36 25MSUS4-53.7-50
			0.75	5	25MSUS4-5.75-5A	25MSUS4-5.75-5
			1.1	8	25MSUS4-51.1-8A	25MSUS4-51.1-7
			1.5	11	25MSUS4-51.5-11A	25MSUS4-51.5-10
			1.9	13	25MSUS4-51.9-13A	25MSUS4-51.9-12
			2.2	15	25MSUS4-52.2-15A	25MSUS4-52.2-14
			2.7	19	25MSUS4-52.7-19A	25MSUS4-52.7-16 25MSUS4-53.7-18 25MSUS4-53.7-23
			3.7	25	25MSUS4-53.7-25A	

■ For well diameter 100mm

Material of wetted parts	Well diameter (mm)	Nominal pump diameter (mm)	Output (kW)	Number of stages	New type	Conventional MSU series
Stainless steel	100	50	0.75	3	50MSUS4-5.75-3	405MSU-S5.75H-3
			1.1	5	50MSUS4-51.1-5	405MSU-S51.1H-5
			1.5	7	50MSUS4-51.5-7	405MSU-S51.5H-7
			1.9	8	50MSUS4-51.9-8	405MSU-S51.9H-8
			2.2	10	50MSUS4-52.2-10	405MSU-S52.2H-10
			2.7	12	50MSUS4-52.7-12	405MSU-S52.7H-12
			3.7	13	50MSUS4-53.7-13	405MSU-S53.7H-13
			3.7	17	50MSUS4-53.7-17	405MSU-S53.7H-17

● For well regulation areas

Material of wetted parts	Well diameter (mm)	Nominal pump diameter (mm)	Output (kW)	Number of stages	New type	Conventional MSU series
Stainless steel	100	25	0.75	3	25MSUS4-5.75-3	402MSU-S5.75H-3
			1.1	5	25MSUS4-51.1-5	402MSU-S51.1H-5
			1.5	7	25MSUS4-51.5-7	402MSU-S51.5H-7
			1.9	8	25MSUS4-51.9-8	402MSU-S51.9H-8
			2.2	10	25MSUS4-52.2-10	402MSU-S52.2H-10
			2.7	12	25MSUS4-52.7-12	402MSU-S52.7H-12
			3.7	13	25MSUS4-53.7-13	402MSU-S53.7H-13
			3.7	17	25MSUS4-53.7-17	402MSU-S53.7H-17

■ For well diameter 150mm

Material of wetted parts	Well diameter (mm)	Nominal pump diameter (mm)	Output (kW)	Number of stages	New type	Conventional MSU series
Stainless steel	150	50	1.9	5	50MSUS6-51.9-5	605MSU-S51.9J-5
			2.2	6	50MSUS6-52.2-6	605MSU-S52.2J-6
			2.7	7	50MSUS6-52.7-7	605MSU-S52.7J-7
			3.7	9	50MSUS6-53.7-9	605MSU-S53.7J-9
			5.5	13	50MSUS6-55.5-13	605MSU-S55.5J-13
			7.5	16	50MSUS6-57.5-16	605MSU-S57.5J-16
			7.5	19	50MSUS6-57.5-19	605MSU-S57.5J-19
		11	24	50MSUS6-511-24	605MSU-S511J-24	
		65	1.9	4	65MSUS6-51.9-4	607MSU-S51.9J-4
			2.2	4	65MSUS6-52.2-4	607MSU-S52.2J-4
			2.7	5	65MSUS6-52.7-5	607MSU-S52.7J-5
			3.7	6	65MSUS6-53.7-6	607MSU-S53.7J-6
			5.5	9	65MSUS6-55.5-9	607MSU-S55.5J-9
			7.5	12	65MSUS6-57.5-12	607MSU-S57.5J-12
			11	15	65MSUS6-511-15	607MSU-S511J-15
			11	18	65MSUS6-511-18	607MSU-S511J-18
		80	15	21	65MSUS6-515-21	607MSU-S515J-21
			15	25	65MSUS6-515-25	607MSU-S515J-25
			3.7	4	80MSUS6-53.7-4	608MSU-S53.7H-4
			5.5	6	80MSUS6-55.5-6	608MSU-S55.5H-6
			7.5	8	80MSUS6-57.5-8	608MSU-S57.5H-8
			11	11	80MSUS6-511-11	608MSU-S511H-11
		15	15	80MSUS6-515-15	608MSU-S515H-15	

■ For well diameter 200mm

Material of wetted parts	Well diameter (mm)	Nominal pump diameter (mm)	Output (kW)	Number of stages	New type	Conventional MSU series
Stainless steel	200	80	3.7	2	80MSUS8-53.7-2	808MSU-S53.7H-2
			5.5	3	80MSUS8-55.5-3	808MSU-S55.5H-3
			7.5	4	80MSUS8-57.5-4	808MSU-S57.5H-4
			11	6	80MSUS8-511-6	808MSU-S511H-6
			15	8	80MSUS8-515-8	808MSU-S515H-8
			18.5	10	80MSUS8-518-10	808MSU-S518H-10
			22	12	80MSUS8-522-12	808MSU-S522H-12
			26	14	80MSUS8-526-14	808MSU-S526H-14
			30	16	—	808MSU-S530H-16
			37	20	—	808MSU-S537H-20
		100	3.7	1	100MSUS8-53.7-1	—
			5.5	2	100MSUS8-55.5-2	810A-MSU-S55.5H-2
			7.5	3	100MSUS8-57.5-3	810A-MSU-S57.5H-3
			11	4	100MSUS8-511-4	810A-MSU-S511H-4
			15	5	100MSUS8-515-5	810A-MSU-S515H-5
			18.5	6	100MSUS8-518-6	810A-MSU-S518H-6
			22	7	100MSUS8-522-7	810A-MSU-S522H-7
			26	8	100MSUS8-526-8	810A-MSU-S526H-8
			30	10	100MSUS8-530-10	810A-MSU-S530H-10
			37	12	100MSUS8-537-12	810A-MSU-S537H-12

■ For well diameter 75mm

Material of wetted parts	Well diameter (mm)	Nominal pump diameter (mm)	Output (kW)	Number of stages	New type	Conventional MSU series
Cast iron	75	25	0.4	16	25MSU3-5.4-16	MSU-3116F
			0.75	30	25MSU3-5.75-30	MSU-3130F

■ For well diameter 125mm

Material of wetted parts	Well diameter (mm)	Nominal pump diameter (mm)	Output (kW)	Number of stages	New type	Conventional MSU series
Cast iron	125	40	1.5	7	40MSU5-51.5-7	504MSU-51.5H-7
			2.2	11	40MSU5-52.2-11	504MSU-52.2H-11
			3.7	18	40MSU5-53.7-18	504MSU-53.7H-18

■ For well diameter 150mm

Material of wetted parts	Well diameter (mm)	Nominal pump diameter (mm)	Output (kW)	Number of stages	New type	Conventional MSU series
Cast iron	150	40	5.5	25	40MSU6-55.5-25	604MSU-55.5H-25
			7.5	35	40MSU6-57.5-35	604MSU-57.5H-35

■ For well diameter 200mm

Material of wetted parts	Well diameter (mm)	Nominal pump diameter (mm)	Output (kW)	Number of stages	New type	Conventional MSU series
Cast iron	200	80	3.7	2	80MSU8-53.7-2	—
			5.5	3	80MSU8-55.5-3	—
			7.5	4	80MSU8-57.5-4	—
			11	6	80MSU8-511-6	—
			15	8	80MSU8-515-8	—
			18.5	10	80MSU8-518-10	—
			22	11	80MSU8-522-11	—
			26	13	80MSU8-526-13	—
		30	15	80MSU8-530-15	—	
		100	3.7	1	100MSU8-53.7-1	—
			5.5	2	100MSU8-55.5-2	—
			7.5	2	100MSU8-57.5-2	—
			7.5	3	100MSU8-57.5-3	—
			11	3	100MSU8-511-3	—
			11	4	100MSU8-511-4	—
			15	4	100MSU8-515-4	—
			15	5	100MSU8-515-5	—
			18.5	5	100MSU8-518-5	—
			18.5	6	100MSU8-518-6	—
			22	6	100MSU8-522-6	—
			22	7	100MSU8-522-7	—
			26	7	100MSU8-526-7	—
			26	8	100MSU8-526-8	—
			30	8	100MSU8-530-8	—
			30	10	100MSU8-530-10	—
			37	10	100MSU8-537-10	—
			37	13	100MSU8-537-13	—
			7.5	2	100MSU8-57.5-2B	810B-MSU-57.5-2
			11	3	100MSU8-511-3B	810B-MSU-511-3
			15	4	100MSU8-515-4B	810B-MSU-515-4
			18.5	5	100MSU8-518-5B	810B-MSU-518-5
			22	6	100MSU8-522-6B	810B-MSU-522-6
			26	6	100MSU8-526-6B	810B-MSU-526-6
30	7		100MSU8-530-7B	810B-MSU-530-7		
37	9	100MSU8-537-9B	810B-MSU-537-9			

■ For well diameter 250mm

Material of wetted parts	Well diameter (mm)	Nominal pump diameter (mm)	Output (kW)	Number of stages	New type	Conventional MSU series
Cast iron	250	100	45	12	100MSU10-545-12	1010MSU-545H-12
			7.5	1	125MSU10-57.5-1	1013MSU-57.5H-1
		125	11	1	125MSU10-511-1	1013MSU-511H-1
			11	2	125MSU10-511-2	1013MSU-511H-2
			15	2	125MSU10-515-2	1013MSU-515H-2
			18.5	2	125MSU10-518-2	1013MSU-518H-2
			22	3	125MSU10-522-3	1013MSU-522H-3
			26	3	125MSU10-526-3	1013MSU-526H-3
			30	4	125MSU10-530-4	1013MSU-530H-4
			37	4	125MSU10-537-4	1013MSU-537H-4
			45	5	125MSU10-545-5	1013MSU-545H-5
			55	6	125MSU10-555-6	1013MSU-555H-6

■ For well diameter 300mm

Material of wetted parts	Well diameter (mm)	Nominal pump diameter (mm)	Output (kW)	Number of stages	New type	Conventional MSU series
Cast iron	300	150	11	1	150MSU12-511-1	1215MSU-511H-1
			15	1	150MSU12-515-1	1215MSU-515H-1
			18.5	1	150MSU12-518-1	1215MSU-518H-1
			22	2	150MSU12-522-2	1215MSU-522H-2
			26	2	150MSU12-526-2	1215MSU-526H-2
			30	2	150MSU12-530-2	1215MSU-530H-2
			37	2	150MSU12-537-2	1215MSU-537H-2
			45	3	150MSU12-545-3	1215MSU-545H-3
			55	3	150MSU12-555-3	1215MSU-555H-3
			75	4	150MSU12-575-4	1215MSU-575H-4

■ For well diameter 350mm

Material of wetted parts	Well diameter (mm)	Nominal pump diameter (mm)	Output (kW)	Number of stages	New type	Conventional MSU series
Cast iron	350	200	30	1	200MSU14-530-1	1420MSU-530H-1
			37	1	200MSU14-537-1	1420MSU-537H-1
			45	2	200MSU14-545-2	1420MSU-545H-2
			55	2	200MSU14-555-2	1420MSU-555H-2
			75	2	200MSU14-575-2	1420MSU-575H-2

■ For well diameter 400mm

Material of wetted parts	Well diameter (mm)	Nominal pump diameter (mm)	Output (kW)	Number of stages	New type	Conventional MSU series
Cast iron	400	250	22	1	250MSU16-522-1	—
			30	2	250MSU16-530-2	—
			37	2	250MSU16-537-2	—
			45	2	250MSU16-545-2	—
			45	3	250MSU16-545-3	—
			55	3	250MSU16-555-3	—
			75	4	250MSU16-575-4	—

■ Pumps for hot springs

Material of wetted parts	Well diameter (mm)	Nominal pump diameter (mm)	Output (kW)	Number of stages	New type	Conventional MSU series	
Stainless steel	100	25	0.6	11	25MSUH4-5.6-11	—	
			0.75	13	25MSUH4-5.75-13	—	
			1.1	19	25MSUH4-5.1.1-19	—	
			1.5	26	25MSUH4-5.1.5-26	—	
			2.2	38	25MSUH4-5.2.2-38	—	
			2.2	44	25MSUH4-5.2.2-44	—	
		32	0.75	10	32MSUH4-5.75-10	—	
			1.1	15	32MSUH4-5.1.1-15	—	
			1.5	15	32MSUH4-5.1.5-15	—	
			1.5	20	32MSUH4-5.1.5-20	—	
			2.2	30	32MSUH4-5.2.2-30	—	
			3.7	36	32MSUH4-5.3.7-36	—	
			3.7	50	32MSUH4-5.3.7-50	—	
			40	0.75	5	40MSUH4-5.75-5	—
				1.1	7	40MSUH4-5.1.1-7	—
		1.5		10	40MSUH4-5.1.5-10	—	
		2.2		14	40MSUH4-5.2.2-14	—	
		3.7		18	40MSUH4-5.3.7-18	—	
		3.7		23	40MSUH4-5.3.7-23	—	
		50	0.75	3	50MSUH4-5.75-3	—	
			1.1	5	50MSUH4-5.1.1-5	—	
			1.5	7	50MSUH4-5.1.5-7	—	
			2.2	10	50MSUH4-5.2.2-10	—	
			3.7	13	50MSUH4-5.3.7-13	—	
			3.7	17	50MSUH4-5.3.7-17	—	
		150	50	3.7	9	50MSUH6-5.3.7-9	—
				5.5	13	50MSUH6-5.5.5-13	—
				7.5	16	50MSUH6-5.7.5-16	—
				7.5	19	50MSUH6-5.7.5-19	—
				11	24	50MSUH6-5.11-24	—
			65	3.7	6	65MSUH6-5.3.7-6	—
				5.5	9	65MSUH6-5.5.5-9	—
				7.5	12	65MSUH6-5.7.5-12	—
				11	15	65MSUH6-5.11-15	—
				11	18	65MSUH6-5.11-18	—
				15	21	65MSUH6-5.15-21	—
				15	25	65MSUH6-5.15-25	—
				80	3.7	4	80MSUH6-5.3.7-4
			5.5		6	80MSUH6-5.5.5-6	—
			7.5		8	80MSUH6-5.7.5-8	—
			11		11	80MSUH6-5.11-11	—
			15		15	80MSUH6-5.15-15	—



TERAL INC.

Head Office 230, Moriwake, Miyuki-cyo, Fukuyama-city, Hiroshima, 720-0003, Japan
Tel.+81-84-955-1111 Fax.+81-84-955-5777
www.teral.net

Teral Asia Limited

Room 1001,10/F, Olympia Plaza, 255 King's Road, North Point, Hong Kong
Tel.+852-2571-0935 Fax.+852-2571-0619

TERAL THAI CO.,LTD.

150 Moo 16 Udomsoraryuth Rd., T.Bangkrasan, A.Bangpa-In, Ayutthaya 13160 Thailand
Tel.+66-3535-2148-9 Fax.+66-3535-2150

TERAL TRADING & SERVICE CO.,LTD.

150 Moo 16 Udomsoraryuth Rd., T.Bangkrasan, A.Bangpa-In, Ayutthaya 13160 Thailand
Tel.+66-3535-2145-7 Fax.+66-3535-8549

PT.Teral Indonesia Pumps and Fans

Sinpasa Commercial Blok SB No 001
Jl. Boulevar Selatan Summarecon Bekasi
RT.003/RW.005, Kel. Marga Mulya, Kec. Bekasi Utara, Kota Bekasi, Jawa Barat 17142
TEL:+62-21-8949-4116

Teral Vietnam Limited Liability Company

9th Floor, LADECO Building, No.266 Doi Can Street, Ngoc Ha Ward, Hanoi City, Vietnam
Tel.+84-24-393-52-790 Fax.+84-24-393-52-289

Teral General Machine (Shanghai) Co.,Ltd.

No.285, Yuan Qu Road(N), Bei Qiao, Min Hang District, Shanghai 201109, China
Tel.+86-21-6490-9128 Fax.+86-21-6490-9126

Teral Middle East F.Z.C.

1806-002, 18th floor, BB1, Mazaya Business Avenue, JLT, Dubai, UAE. PO Box 414781
Tel.+971-4369 9039

Teral Pumps & Fans North America Ltd.

Suite # 197, 800-15355 24 Ave Surrey, B.C., CANADA V4A 2H9
Tel.+1-604-839-1008