

Coolant Pump

Model : VKA-e/VKC-e

⚠ WARNING

Do not operate, service or inspect this pump until you have read and understood this manual.

Keep this manual in a safe place where it can be consulted at any time.

To : All mechanical Contractor

Make sure to supply copies of this manual to the customer's operator maintenance and inspection personnel.

Limited warranties

1. In the event of failure or breakage under proper use of the product during the warranty period, equipment supplied by Teral Inc. shall be repaired or replaced free of charge within the scope of the relevant part, provided that such failure or breakage is attributable to inadequacy of the design or workmanship of the equipment.
The warranty period of this product shall be one year after the date of delivery.
2. The warranty mentioned in the above clause shall be only the mechanical warranty of the defective part, and shall not cover any expenses or other damage arising from the failure or breakage.
3. In the event of the following failures and breakage, the costs of the repairs shall be borne by the user.
 - (1) Failures and breakage attributable to equipment that was not delivered by Teral Inc.
 - (2) Failures and breakage after the expiration of the warranty period
 - (3) Failures and breakage caused by disasters or force majeure, such as fire, acts of God or earthquakes
 - (4) Failures and breakage resulting from repairs or modifications made without the consent of Teral Inc.
 - (5) Failures and breakage when parts other than those designated by Teral Inc. are used
 - (6) Failures and breakage caused by use or storage outside the specification range
4. Teral Inc. shall not be liable for the damage caused by incorrect or reckless use of the pump. Cost and expenses incurred for sending engineer(s) in such a case shall be borne by the user.
5. If the cause of the failure is unclear, necessary actions shall be determined through mutual consultation.

<Chargeable repair>

Investigation and repair work after the warranty period shall become chargeable. The repair and investigation of the above-mentioned failures outside the warranty range shall be undertaken by Teral Inc., even though outside the warranty period.

Purpose of this manual

The purpose of this manual is to provide the user with detailed information necessary to properly operate, maintain and inspect the pump. This product may cause an unexpected accident when handed incorrectly. Please use the product correctly according to this instruction manual.

This manual contains the following information and is intended for persons experienced in the operation of pumps, or for those who have been trained by such experienced operators. Only qualified personnel such as licensed electrical engineers are allowed to carry out the electrical wiring work.

Contents

| | Page |
|---|------|
| Limited warranties..... | I |
| Purpose of this manual..... | II |
| Contents | II |
| 1. Safety precautions..... | 1-1 |
| 1.1 Types and meanings of warning terms and graphic symbols | 1-1 |
| 1.2 Safety precautions..... | 1-1 |
| 1.3 Location of warning labels and caution labels..... | 1-3 |
| 2. Configuration and overview of the pump..... | 2-1 |
| 2.1 Part names and functions..... | 2-1 |
| 2.2 Model description | 2-1 |
| 2.3 Standard specifications | 2-2 |
| 2.4 Information indicated on the nameplates | 2-3 |
| 2.5 Specification table..... | 2-4 |
| 2.6 Dimensional outline drawing and dimensions table | 2-5 |
| 2.7 Internal structure drawing..... | 2-7 |
| 3. Transportation, conveyance, storage and installation | 3-1 |
| 3.1 Precautions for transporting, moving and storing the pump | 3-1 |
| 3.2 Before using the pump | 3-1 |
| 3.3 Precautions for installation | 3-2 |
| 3.4 Precautions for piping work..... | 3-4 |
| 3.5 Precautions for wiring work | 3-4 |
| 4. Operation..... | 4-1 |
| 4.1 Check items before test operation..... | 4-1 |
| 4.1.1 Check items related to the electrical system | 4-1 |
| 4.1.2 Check items related to the pump | 4-1 |
| 4.2 Running the pump (test operation)..... | 4-2 |
| 5. Maintenance and inspection..... | 5-1 |
| 5.1 Precautions for maintenance and inspection | 5-1 |
| 5.2 Mechanical seal..... | 5-2 |
| 5.3 Daily check | 5-3 |
| 5.4 Periodic inspection | 5-3 |
| 6. Troubleshooting..... | 6-1 |
| 7. After-sales service | 7-1 |
| 8. Disposal..... | 8-1 |
| 8.1 Precautions for disposal | 8-1 |

1. Safety precautions

1.1 Types and meanings of warning terms and graphic symbols

This instruction manual divides precautions into the following four categories according to the level of hazards (or the severity of the accident). In addition, prohibited or mandatory actions as well as cautions are indicated with a graphic symbol.

Be sure to understand the meanings of the following terms and comply with the content (instructions) of the instruction manual

■ Explanation of the warning terms

| Warning Term | Meaning |
|----------------|--|
| Danger | Indicates an imminently hazardous situation. Failure to observe this will result in death or serious injury. |
| Warning | Indicates a potentially hazardous situation. Failure to observe this will result in death or serious injury. |
| Caution | Indicates a potentially hazardous situation. Failure to observe this will result in minor or moderate injury or property damage. |
| Note | Indicates information that is in particular to be noted or emphasized. |













■ Explanation of the graphic symbols















| | |
|--|--|
| Don'ts Do not touch Do not disassemble Do not touch with wet hand Do not expose to water | <p>These graphic symbols indicate prohibited actions (that must not be done).</p> |
| Do's Caution Electric shock hazard Rotation hazard Hot surface | <p>This graphic symbol indicates mandatory actions (that must be done).</p> <p>These graphic symbols indicate existing hazards to beware of.</p> |























1.2 Safety precautions

| Danger | |
|---------------|--|
| | Do not touch any energized parts after turning on the main power. Doing so may cause electric shock leading to death because high voltage is applied to the energized part. |
| | Do not use the product in any explosive atmosphere. Doing so may cause an injury and fire. |

| Warning | |
|----------------|---|
| | Properly move the unit according to lifting instructions. Otherwise, the unit may fall, resulting in injury and/or damage. |
| | Do not use the pump or perform any work when it is kept lifted. Otherwise, the unit may fall, resulting in injury and/or damage. |
| | Only those who are authorized by the site manager are allowed to operate the pump. Operation by unskilled personnel may lead to an unforeseen accident. |
| | Installation, maintenance, and inspection must only be carried out by personnel who have been trained to handle the pump. Operation by unskilled personnel may lead to an unforeseen accident. |
| | Only qualified personnel, such as licensed electrical engineers, are allowed to carry out any electric work. Otherwise, it may lead to an electric shock, fire, failures, and/or other problems. |
| | Use high-quality wiring equipment and devices, and carry out wiring work safely and securely according to the technical standards for electrical facilities, as well as the indoor wiring regulations. Otherwise, it may lead to an electric shock, fire, and/or other problems. |
| | Do not connect the ground wire to a gas pipe or water pipe. Such a connection is illegal and leads to an electric shock, explosion and/or fire. |
| | Securely install the ground wire and ensure to carry out grounding work. Otherwise, it may lead to an electric leak and/or electric shock. |
| | Do not operate the pump when its action or parts are abnormal. Otherwise, it may lead to injury, failures and/or various accidents. |
| | Wiring must be performed reliably according to the connection diagram within the terminal box and the instruction manual. Incorrect wiring may cause fire, electric shock and other accidents. |

|  Warning | |
|---|---|
|  Be sure to keep the terminal box cover attached during the operation of the pump. Otherwise, it may lead to an electric shock. |  Do not forcibly bend or pull the power cable and the lead wire of the product. Avoid putting them between objects. Failure to observe this may cause an electric shock or fire. |
|  Only after detaching a companion flange from each pump, screw a pipe into it. Failure to observe this may cause damage or leakage. |  Before starting the maintenance or inspection work, be sure to stop the pump and turn off the main power of the panel board. Failure to observe this may cause electric shock, injury, damage or leakage. |
|  Check that the wire connections and wiring sections are free from looseness. Looseness may cause a fire or electric shock. |  Before rotating the main shaft by hand to check its smooth rotation, be sure to disconnect the main power supply. Otherwise, it may lead to injury and/or damage. |
|  Before starting the unit or carrying out maintenance/inspection work, ensure that all the relevant workers are informed of the operation and that there are no workers in the dangerous zone around the unit. Otherwise, it may lead to an unforeseen accident. |  Never perform zero-discharge operation. Failure to observe this may increase the internal temperature and pressure of the pump, leading to damage and steam spouting. |
|  Do not touch any part of the pump that does not need operation, after energized. Failure to observe this may cause electric shock or injury. |  If you need to disassemble the pump for check, parts change, repair and other work, ask the vendor or the service provider specified by Teral Inc. Work needing expertise may lead to an accident or failure when an inexperienced person does such work. |
|  Do not put your fingers or other objects into the opening and rotating part of the motor during operation. Otherwise, it may lead to injury and/or damage. |  Be sure to turn off the power switch if an electric outage occurs. At the time of power restoration, the machine may suddenly operate, leading to an injury. |

|  Caution | |
|---|---|
|  Do not use the unit outside the range of the product specifications. Otherwise, an electric shock, a fire, leaks, or failures may occur. |  Do not use the unit at an incorrect power voltage. The motor may get damaged if used with an incorrect supply voltage. |
|  Do not use a single unit as the only means of directly operating key facilities or sustaining life. Otherwise, a failure may lead to the suspension of water supply. Be sure to get a backup machine ready. |  Ensure that the delivered container is placed in the correct orientation (not upside down) before unpacking. Carefully unpack the container, while paying special attention to nails. Otherwise, it may lead to injury and/or damage. |
|  The floor in the pump installation area must be provided with water-proofing and drainage measures. Otherwise, significant damage may be caused in case of a leak. |  Do not put the cables or control line of other equipment in the same pipe or duct. Otherwise, it may damage the unit and/or other equipment. |
|  Do not step on the pump and motor. Otherwise, it may lead to injury, damage, and/or other problems. |  Do not allow a liquid to splash on the motor. Otherwise, it may lead to an electric shock, electric leak, failures, and/or other problems. |
|  Operate the controls carefully. Otherwise, it may lead to injury and/or damage. |  During test operation, never run the pump dry (i.e. never run the pump when the liquid level is below the minimum level). Failure to observe this may cause damage or a fire. |
|  Prior to operation, clean the interior of piping thoroughly to remove foreign matter. Otherwise, the foreign matter in the piping system may get into the pump, leading to an accident or pump failure by conveyance of the mixed liquid. |  During normal operation, never run the pump dry for more than 30 seconds. Failure to observe this may cause damage or a fire. |
|  Do not put a cloth on the motor. Failure to observe this may cause overheating or ignition. |  Do not touch the motor body during operation or immediately after the stop of operation. Failure to observe this may cause a burn due to high temperature of the pump. |

|  Caution | |
|--|--|
|  In the event of an alarm or abnormal condition that cannot be resolved, immediately stop the operation and contact Teral Inc. or its service provider. Otherwise, it may lead to an accident. |  Do not operate the pump when tools or other items are placed on the pump. Otherwise, it may lead to injury and/or damage. |
|  Check to verify that the product is exactly what you ordered. The use of a wrong product may cause an injury or failure. |  Be sure to conduct inspection according to the maintenance checklist. Otherwise, you cannot prevent potential failures, thus leading to a higher risk of accidents. |
|  Check the rotating direction of the pump before being coupled with the machine. Failure to observe this may cause an injury or damage. |  Do not provide any strainer at the tip of the pump. Failure to observe this may cause the strainer to come off, resulting in an injury or damage. |
|  Do not place any obstacle that disturbs ventilation, around the product. Failure to observe this may cause a fire. |  Do not place any combustible objects around the product. Failure to observe this may cause a fire. |
|  Do not run the pump at a frequency exceeding 60 Hz. Failure to observe this may cause a burnout or fire. |  Do not touch the impeller, screw, tie bolt, strainer, or other items with bare hands. Failure to observe this may cause an injury or damage. |
|  Be sure to install an overcurrent protection device. Installation of the device is obliged by the Technical Standards for Electrical Equipment. Failure to observe this may cause a fire or damage due to damage to the product. In addition, it is recommended to install a protective device, e.g. an earth leakage circuit breaker. |  Do not use any operating fluid beyond the viscosity limit. Failure to observe this may cause a burnout or fire. |
|  Do not run the pump with its strainer removed. Failure to observe this may cause an injury or damage. |  Do not touch any terminal or wire when measuring the insulation resistance. Failure to observe this may cause an electric shock. |
|  Do not touch the impeller, screw, or other parts after removing the strainer. Failure to observe this may cause an injury. |  After power-off, do not restart the pump until it comes to a complete stop. Failure to observe this may cause an excessive load to act on the main shaft, resulting in a shortened service life of the pump. |
|  Do not use thinner or benzene for cleaning the product. Failure to observe this may cause the product to be discolored or the coating to be peeled off. |  If using a solvent for cleaning the product, pay attention to the handling and use environment of the solvent. Failure to observe this may cause poisoning. |
|  When lifting the product, pay attention to its center of gravity. Failure to observe this may cause the product to topple over or fall down, leading to an injury. |  Dispose of the product as industrial waste. |
|  When lifting the product, give attention to its weight. Do not allow any product heavier than 15 kg to be lifted by a single person. Failure to observe this may put a burden on the body, leading to an injury. |  If adopting star-delta starting, use a starter with an electromagnetic switch (three-contactor type) on the primary side. Failure to observe this may cause a fire. |

1.3 Location of warning labels and caution labels

The figure below shows the locations of warning labels and caution labels. If these labels become dirty and hard to read or if they are peeled off, replace them with a new one.

 **Warning**

 **Caution**





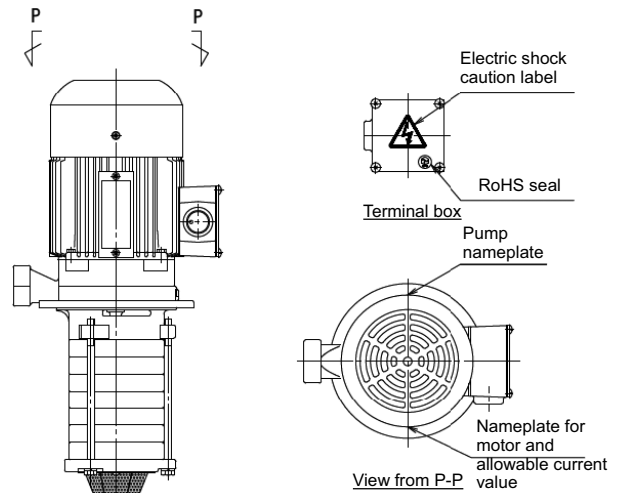

Observe all the warnings and cautions affixed to the machine as well as those described in this instruction manual.



2. Configuration and overview of the pump

This chapter describes the standard specifications of the pump. For details, refer to the delivery specifications such as the dimensional outline drawing and the internal structure drawing. If you have purchased a customized product, some information in this chapter may not be applicable to your unit. Refer to the dimensional outline drawing, the internal structure drawing, and other documents to check the product specifications in such a case.



Caution



Do not use this product under any conditions other than those provided in the specifications. Otherwise, an electric shock, a fire, leaks, or failures may occur.

2.1 Part names and functions

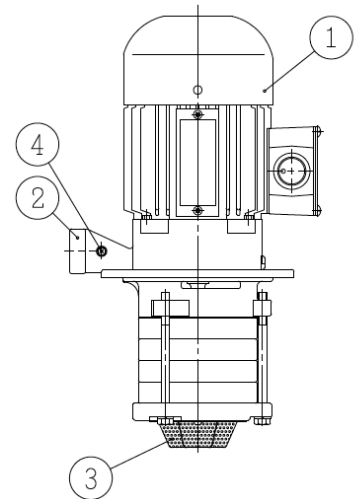
- ① Motor
- ② Discharge port
- ③ Suction port (Strainer)
- ④ Air vent (not provided with the VKA-e models with Rp3/4 discharge bore)

Vents the air in the pump to prevent dry run, if it is impossible to open the discharge piping to the atmosphere.



2.2 Model description

VKA 9 9 6 A H -e
 ① ② ③ ④ ⑤ ⑥ ⑦

- | | |
|------------------------------------|--|
| ① Model | ⑤ Phase and frequency (A: 3-phase, 50Hz/60Hz) |
| ② Number of impellers (1 to 9) | ⑥ Characteristics (H: Pressure type, Q: Flow rate type) |
| ③ Number of casing stages (2 to 9) | ⑦ With a built-in top runner efficiency (IE3-equivalent) motor |
| ④ Series number | |

VKC 7 9 6 A H -e
 ① ② ③ ④ ⑤ ⑥ ⑦

- | | |
|------------------------------------|--|
| ① Model | ⑤ Phase and frequency (A: 3-phase, 50Hz/60Hz) |
| ② Number of impellers (1 to 7) | ⑥ Characteristics (H: Pressure type, Q: Flow rate type) |
| ③ Number of casing stages (2 to 9) | ⑦ With a built-in top runner efficiency (IE3-equivalent) motor |
| ④ Series number | |

2.3 Standard specifications *

| Model | | VKA-e | VKC-e |
|-------------------------|---------------------------|---|---|
| Applicable liquid | Quality | Grinding fluid, cutting fluid, etc. after secondary treatment ^{Note 1,3} | Grinding fluid, cutting fluid, etc. after secondary treatment ^{Note 2,3} |
| | Temperature | -20 to 40°C (No freezing is allowed.) | -20 to 90°C (No freezing is allowed.) |
| | Dynamic viscosity | See "Note 4." | |
| Installation location | | Indoors, Height above sea level: 1,000 m or less, Ambient temperature: -20 to 40°C, Humidity: less than 85%RH (No condensation is allowed.), Place not exposed to direct sunlight, Place whose atmosphere contains no corrosive gas, explosive gas or vapor | |
| Material | Pump leg | FC150 | SCS14A |
| | Casing | SUS304 | SUS304 |
| | Suction chamber | FC200 | SCS14A |
| | Impeller | SUS304 | SUS304 |
| | Main shaft (motor / pump) | S35C+SUS403 | SUS403+SUS403 |
| Shaft sealing structure | | Mechanical seal | |
| Motor | Type | Totally-enclosed fan-cooled indoor type | |
| | IP protection | IP54 | |
| | Power ^{Note 3} | 3-phase 50/60Hz | 200/200-220V |
| | Insulation class | Class F | |
| | Number of poles | 2P | |
| | Standard | IEC60034-1 | |
| Noise | | 69dB(A) | |
| Coating color | Pump | Munsell N1 | |
| | Motor | - Body & outer fan cover - Terminal box | - Melamine-baked, Munsell N1 (gloss) - Cationic coating (black) |

Note 1 VKA-e model cannot be used with special liquids such as water, printing liquid, and acidic liquid. Please use it with the liquid with rust-prevention effect.

Note 2 VKC-e model cannot be used with special liquids such as printing liquid and acidic liquid.

Note 3 Under the conditions that contain hard sludge—such as abrasive powders, grinding powders, and diamond abrasive grains—in the pumping fluid, the service life of the mechanical seal may become shorter. In such a case, install a filter (e.g. magnet filter or paper filter).

Note 4 When the dynamic viscosity of liquids used becomes higher than that in the table below, the useful life of the motor may become shorter, leading to a burnout. Be sure to use a liquid with a dynamic viscosity lower than its lime value in the table below. In addition, the dynamic viscosity of a liquid may drastically increase with decreasing temperature of the liquid. When using a liquid, confirm the dynamic viscosity of the liquid when its temperature is lowest. The characteristics of the pump deteriorate as an increase in the dynamic viscosity of the liquid used.

| Model | Applicable limit value of dynamic viscosity [mm ² /s] | |
|---|--|-------------------|
| | Operation at 50Hz | Operation at 60Hz |
| VKA(C)4□6AH-e, VKA(C)7□6AH-e VKA(C)4□6AQ-e, VKA6□6AQ-e | 75 | 37.5 |
| Any other models | 75 | 75 |

Note 5 Limit the fluctuations of the power voltage within ±10% of the rated voltage, and also limit the fluctuations of the frequency within -5% to +3% of the rated value. Avoid continuous operation if the voltage is not within the range of ±5% of the rated value or if the frequency is not within the range of ±2% of the rated value.

* This product is labeled with the CE self-declaration mark and complies with the Essential Safety Requirements (ESRs) of the "EU (EC) Directive." The following are the general descriptions.

| | |
|---------------------------|---|
| Manufacturer | Teral Inc. 230 Moriwake, Miyuki-cho, Fukuyama-city, Hiroshima 720-0003 Japan |
| Product | VKA-e/VKC-e model coolant pump |
| Standards | Machinery Directive 2006/42/EC |
| | EN 809/A1:2009, EN ISO 12100:2010, EN 60204-1/A1:2009 |
| Manufacturer (Japan) | Teral Inc., Hiroshima |
| Administrator (EU nation) | Shiran Tower 5F Luzna 716/2 160 00 Vokovice, Praha 6 CZECH REPUBLIC Person in charge: Tomohisa Yamamoto |
| Place of declaration | Hiroshima, Japan Manager: Taiji Monden |

2.4 Information indicated on the nameplates

The pump nameplate (for indicating the pump specifications) and the motor nameplate (for indicating the motor specifications) are affixed to the product. When you receive the pump, check the pump nameplate to verify that the delivered product is exactly what you ordered. Be sure to confirm the model, nominal output, frequency, and voltage. The following figure and table show the appearance of the pump nameplate and the information indicated on it.

If by any chance you find anything wrong, contact the vendor from which you purchased the product. Do not place any obstacles in front of the nameplate or remove it. Always keep the nameplate clearly visible.



Do not run the pump at a frequency exceeding 60 Hz. Failure to observe this may overload the motor, causing it to burn out.

| | | | | | |
|--|---|--------------|--------------------------------|-----|---------|
| TERAL | | COOLANT PUMP | | CE | |
| 3-PHASE a. c. INDUCTION MOTOR | | | | | |
| TYPE | ① | Hz | ⑥ | | |
| OUTPUT | ② | kW | VOLT | ⑦ | |
| PIPE SIZE | ③ | B | AMP | ⑧ | |
| HEAD | ④ | m | min ⁻¹ | ⑨ | |
| Q' TY | ⑤ | L/min | Maximum safe operating speed ⑩ | | |
| Year of manufacture | | | ⑪ | BRG | D-END ⑬ |
| Main document NO. | | | ⑫ | | N-END ⑭ |
| SER NO. ⑮ | | | | | |
| 230, Moriwake, Miyuki-cho, Fukuyama-city, Hiroshima, 720-0003, Japan TERAL INC. M-6521-- | | | | | |

Pump nameplate

| Symbol | Item |
|--------|--|
| 1 | Model |
| 2 | Nominal output (kW) ^{*1} |
| 2 | Motor output (kW) |
| 3 | Nominal discharge diameter (B) |
| 4 | Total head (m) |
| 5 | Discharge rate (L/min) |
| 6 | Frequency (Hz) |
| 7 | Voltage (V) |
| 8 | Current (A) ^{*2} |
| 9 | Rotating speed (min ⁻¹) |
| 10 | Max. permissible rotating speed (min ⁻¹) |
| 11 | Year of manufacture |
| 12 | Instruction manual No. |
| 13 | Inboard bearing type |
| 14 | Outboard bearing type |
| 15 | Production No. |

*1 The output indicated on the pump nameplate is nominal output and may differ from the rated output of the motor. The nominal output is an approximate output value when the pump runs at a dynamic viscosity of 1 mm²/s.

*2 The electric current indicated on the pump nameplate may differ from the rated current of the motor. The electric current indicated on the pump nameplate is based on actual use. Teral recommends using this value as the setup current value of the protective device.

2.5 Specification table

• Models VKA-AH-e

| Model | VKA1□6AH-e | | VKA2□6AH-e | | VKA3□6AH-e | | VKA4□6AH-e | | VKA5□6AH-e | | VKA6□6AH-e | | VKA7□6AH-e | | VKA8□6AH-e | | VKA9□6AH-e | |
|--|------------|--------------|------------|--------------|------------|--------------|------------|--------------|------------|--------------|------------|--------------|------------|--------------|------------|--------------|------------|--------------|
| Nominal output (kW) | 0.1 | 0.17 | 0.2 | 0.34 | 0.3 | 0.51 | 0.4 | 0.68 | 0.5 | 0.85 | 0.6 | 1.02 | 0.7 | 1.19 | 0.8 | 1.36 | 0.9 | 1.53 |
| Rated voltage (V) | 200 | 200 220 | 200 | 200 220 | 200 | 200 220 | 200 | 200 220 | 200 | 200 220 | 200 | 200 220 | 200 | 200 220 | 200 | 200 220 | 200 | 200 220 |
| Frequency (Hz) | 50 | 60 | 50 | 60 | 50 | 60 | 50 | 60 | 50 | 60 | 50 | 60 | 50 | 60 | 50 | 60 | 50 | 60 |
| Pump rated current (A) | 2.0 | 1.9 1.9 | 2.6 | 2.3 2.3 | 3.5 | 3.5 3.5 | 4.0 | 4.0 4.0 | 5.5 | 5.6 5.4 | 5.9 | 6.0 5.8 | 6.4 | 6.0 5.8 | 7.0 | 8.4 7.9 | 7.6 | 9.6 8.8 |
| Starting current (A) | 11.1 | 10.8 11.9 | 11.1 | 10.8 11.9 | 30.0 | 29.0 32.0 | 30.0 | 29.0 32.0 | 56.0 | 55.0 60.0 | 56.0 | 55.0 60.0 | 56.0 | 55.0 60.0 | 84.0 | 73.0 80.0 | 84.0 | 73.0 80.0 |
| Discharge rate (L/min) | 40 | 50 | 40 | 50 | 40 | 50 | 40 | 50 | 40 | 50 | 40 | 50 | 40 | 50 | 40 | 50 | 40 | 50 |
| Total head (m) | 7 | 9 | 13 | 18 | 20 | 28 | 27 | 37 | 33 | 46 | 40 | 55 | 48 | 62 | 56 | 77 | 63 | 86 |
| Applicable limit value of dynamic viscosity (mm ² /s) | 75 | 75 | 75 | 75 | 75 | 75 | 75 | 37.5 | 75 | 75 | 75 | 75 | 75 | 37.5 | 75 | 75 | 75 | 75 |
| Standard pipe diameter (Rp) | 3/4 | | 3/4 | | 3/4 | | 3/4 | | 3/4 | | 3/4 | | 3/4 | | 1 1/4 | | 1 1/4 | |

Note1) The discharge rate and the total head are values when each model is tested at a dynamic viscosity of 1 mm²/s (the same viscosity as fresh water at normal temperature). Basically, the above models cannot be used for pumping water. However, contact Teral Inc. for our suggestions.

Note2) The rated current in the above table (current value indicated on the pump nameplate) is the recommended preset current value of the protective device.

• Models VKA-AQ-e

| Model | VKA1□6AQ-e | | VKA2□6AQ-e | | VKA3□6AQ-e | | VKA4□6AQ-e | | VKA5□6AQ-e | | VKA6□6AQ-e | |
|--|------------|--------------|------------|--------------|------------|--------------|------------|--------------|------------|--------------|------------|--------------|
| Nominal output (kW) | 0.18 | 0.3 | 0.36 | 0.6 | 0.54 | 0.9 | 0.72 | 1.2 | 0.9 | 1.5 | 1.1 | 1.8 |
| Rated voltage (V) | 200 | 200 220 | 200 | 200 220 | 200 | 200 220 | 200 | 200 220 | 200 | 200 220 | 200 | 200 220 |
| Frequency (Hz) | 50 | 60 | 50 | 60 | 50 | 60 | 50 | 60 | 50 | 60 | 50 | 60 |
| Pump rated current (A) | 2.4 | 2.2 2.2 | 3.6 | 4.0 4.0 | 5.5 | 6.0 5.8 | 6.4 | 6.0 5.8 | 7.4 | 9.6 8.8 | 8.5 | 10.0 9.1 |
| Starting current (A) | 11.1 | 10.8 11.9 | 30.0 | 29.0 32.0 | 56.0 | 55.0 60.0 | 56.0 | 55.0 60.0 | 84.0 | 73.0 80.0 | 84.0 | 73.0 80.0 |
| Discharge rate (L/min) | 85 | 100 | 85 | 100 | 85 | 100 | 85 | 100 | 85 | 100 | 85 | 100 |
| Total head (m) | 6 | 8 | 13 | 18 | 19 | 28 | 26 | 36 | 33 | 46 | 39 | 54 |
| Applicable limit value of dynamic viscosity (mm ² /s) | 75 | 75 | 75 | 75 | 75 | 75 | 75 | 37.5 | 75 | 75 | 75 | 37.5 |
| Standard pipe diameter (Rp) | 3/4 | | 3/4 | | 3/4 | | 3/4 | | 1 1/4 | | 1 1/4 | |

Note1) The discharge rate and the total head are values when each model is tested at a dynamic viscosity of 1 mm²/s (the same viscosity as fresh water at normal temperature). Basically, the above models cannot be used for pumping water. However, contact Teral Inc. for our suggestions.

Note2) The rated current in the above table (current value indicated on the pump nameplate) is the recommended preset current value of the protective device.

• Models VKC-AH-e

| Model | VKC1□6AH-e | | VKC2□6AH-e | | VKC3□6AH-e | | VKC4□6AH-e | | VKC5□6AH-e | | VKC6□6AH-e | | VKC7□6AH-e | |
|--|------------|--------------|------------|--------------|------------|--------------|------------|--------------|------------|--------------|------------|--------------|------------|--------------|
| Nominal output (kW) | 0.1 | 0.17 | 0.2 | 0.34 | 0.3 | 0.51 | 0.4 | 0.68 | 0.5 | 0.85 | 0.6 | 1.02 | 0.7 | 1.19 |
| Rated voltage (V) | 200 | 200 220 | 200 | 200 220 | 200 | 200 220 | 200 | 200 220 | 200 | 200 220 | 200 | 200 220 | 200 | 200 220 |
| Frequency (Hz) | 50 | 60 | 50 | 60 | 50 | 60 | 50 | 60 | 50 | 60 | 50 | 60 | 50 | 60 |
| Pump rated current (A) | 2.0 | 1.9 1.9 | 2.6 | 2.3 2.3 | 3.5 | 3.5 3.5 | 4.0 | 4.0 4.0 | 5.5 | 5.6 5.4 | 5.9 | 6.0 5.8 | 6.4 | 6.0 5.8 |
| Starting current (A) | 11.1 | 10.8 11.9 | 11.1 | 10.8 11.9 | 30.0 | 29.0 32.0 | 30.0 | 29.0 32.0 | 56.0 | 55.0 60.0 | 56.0 | 55.0 60.0 | 56.0 | 55.0 60.0 |
| Discharge rate (L/min) | 40 | 50 | 40 | 50 | 40 | 50 | 40 | 50 | 40 | 50 | 40 | 50 | 40 | 50 |
| Total head (m) | 7 | 9 | 13 | 18 | 20 | 28 | 27 | 37 | 33 | 46 | 40 | 55 | 48 | 62 |
| Applicable limit value of dynamic viscosity (mm ² /s) | 75 | 75 | 75 | 75 | 75 | 75 | 75 | 37.5 | 75 | 75 | 75 | 75 | 75 | 37.5 |
| Standard pipe diameter (Rp) | 3/4 | | 3/4 | | 3/4 | | 3/4 | | 3/4 | | 3/4 | | 3/4 | |

Note1) The discharge rate and the total head are values when each model is tested at a dynamic viscosity of 1 mm²/s (the same viscosity as fresh water at normal temperature).

Note2) The rated current in the above table (current value indicated on the pump nameplate) is the recommended preset current value of the protective device.

• Models VKC-AQ-e

| Model | VKC1□6AQ-e | | VKC2□6AQ-e | | VKC3□6AQ-e | | VKC4□6AQ-e | |
|--|------------|--------------|------------|--------------|------------|--------------|------------|--------------|
| Nominal output (kW) | 0.18 | 0.3 | 0.36 | 0.6 | 0.54 | 0.9 | 0.72 | 1.2 |
| Rated voltage (V) | 200 | 200 220 | 200 | 200 220 | 200 | 200 220 | 200 | 200 220 |
| Frequency (Hz) | 50 | 60 | 50 | 60 | 50 | 60 | 50 | 60 |
| Pump rated current (A) | 2.4 | 2.2 2.2 | 3.6 | 4.0 4.0 | 5.5 | 6.0 5.8 | 6.4 | 6.0 5.8 |
| Starting current (A) | 11.1 | 10.8 11.9 | 30.0 | 29.0 32.0 | 56.0 | 55.0 60.0 | 56.0 | 55.0 60.0 |
| Discharge rate (L/min) | 85 | 100 | 85 | 100 | 85 | 100 | 85 | 100 |
| Total head (m) | 6 | 8 | 13 | 18 | 19 | 28 | 26 | 36 |
| Applicable limit value of dynamic viscosity (mm ² /s) | 75 | 75 | 75 | 75 | 75 | 75 | 75 | 37.5 |
| Standard pipe diameter (Rp) | 3/4 | | 3/4 | | 3/4 | | 3/4 | |

Note1) The discharge rate and the total head are values when each model is tested at a dynamic viscosity of 1 mm²/s (the same viscosity as fresh water at normal temperature).

Note2) The rated current in the above table (current value indicated on the pump nameplate) is the recommended preset current value of the protective device.

2.6 Dimensional outline drawing and dimensions table

(1) Dimensional outline drawing

Fig. 1

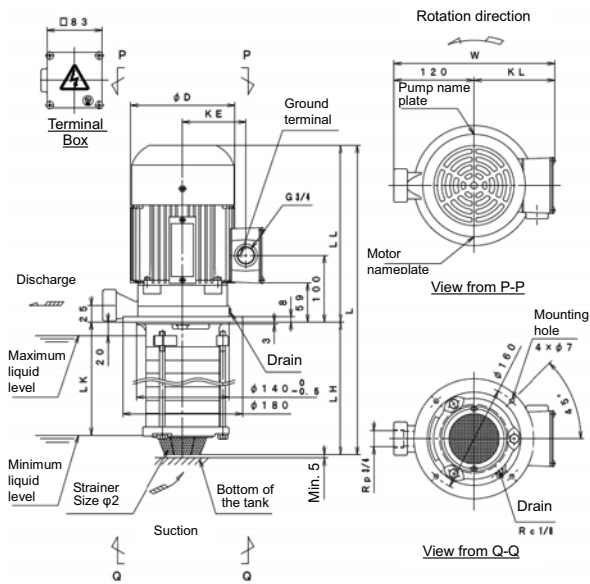

Fig. 2

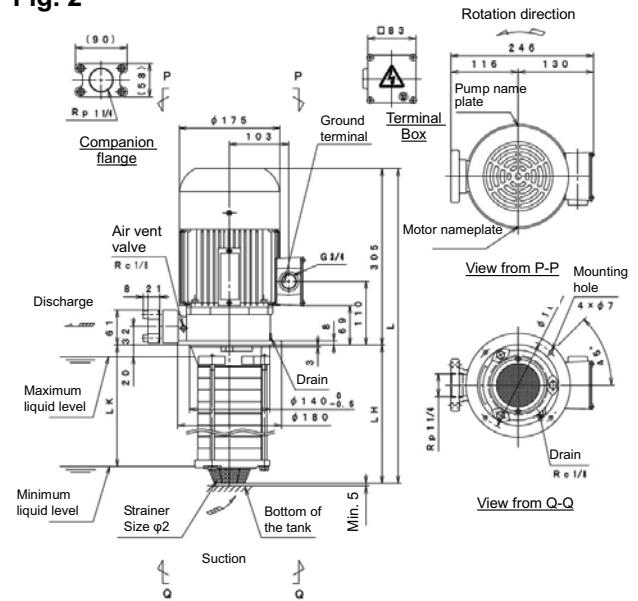
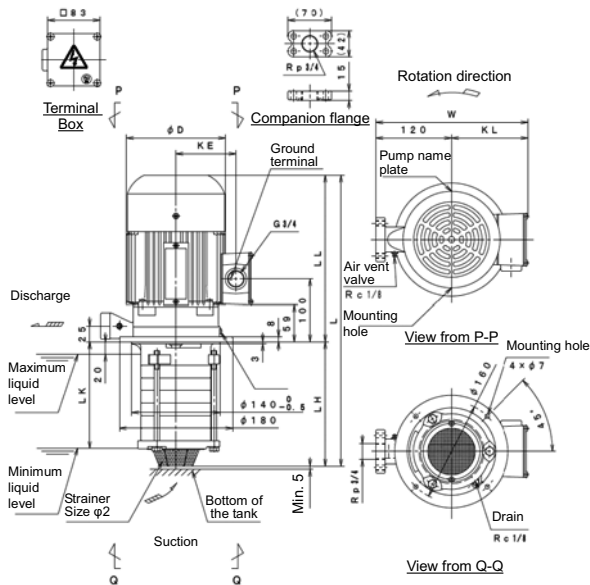

Fig. 3



These figures use a typical model. Some parts vary in shape depending on the model and specifications. Because some of the specifications may be changed due to design changes or for other reasons, please request the delivery specifications when implementing your plan.

(2) Dimensions table

• Models VKA-AH-e

Unit: mm

| Model | Fig. | D | KE | KL | L | LH | LK | LL | W | Estimated mass (kg) |
|------------|------|-----|-----|-----|-----|-----|-----|-----|-----|---------------------|
| VKA136AH-e | 1 | 140 | 88 | 115 | 384 | 139 | 110 | 245 | 235 | 15 |
| VKA146AH-e | | 140 | 88 | 115 | 404 | 159 | 130 | 245 | 235 | 15 |
| VKA156AH-e | | 140 | 88 | 115 | 424 | 179 | 150 | 245 | 235 | 15 |
| VKA166AH-e | | 140 | 88 | 115 | 444 | 199 | 170 | 245 | 235 | 15 |
| VKA236AH-e | | 140 | 88 | 115 | 384 | 139 | 110 | 245 | 235 | 15 |
| VKA246AH-e | | 140 | 88 | 115 | 404 | 159 | 130 | 245 | 235 | 15 |
| VKA256AH-e | | 140 | 88 | 115 | 424 | 179 | 150 | 245 | 235 | 15 |
| VKA266AH-e | | 140 | 88 | 115 | 444 | 199 | 170 | 245 | 235 | 16 |
| VKA276AH-e | | 140 | 88 | 115 | 464 | 219 | 190 | 245 | 235 | 16 |
| VKA286AH-e | | 140 | 88 | 115 | 484 | 239 | 210 | 245 | 235 | 16 |
| VKA296AH-e | | 140 | 88 | 115 | 504 | 259 | 230 | 245 | 235 | 16 |
| VKA336AH-e | | 140 | 88 | 115 | 384 | 139 | 110 | 245 | 235 | 14 |
| VKA346AH-e | | 140 | 88 | 115 | 404 | 159 | 130 | 245 | 235 | 14 |
| VKA356AH-e | | 140 | 88 | 115 | 424 | 179 | 150 | 245 | 235 | 14 |
| VKA366AH-e | | 140 | 88 | 115 | 444 | 199 | 170 | 245 | 235 | 15 |
| VKA376AH-e | | 140 | 88 | 115 | 464 | 219 | 190 | 245 | 235 | 15 |
| VKA386AH-e | | 140 | 88 | 115 | 484 | 239 | 210 | 245 | 235 | 15 |
| VKA396AH-e | | 140 | 88 | 115 | 504 | 259 | 230 | 245 | 235 | 15 |
| VKA446AH-e | | 140 | 88 | 115 | 404 | 159 | 130 | 245 | 235 | 14 |
| VKA456AH-e | | 140 | 88 | 115 | 424 | 179 | 150 | 245 | 235 | 14 |
| VKA466AH-e | | 140 | 88 | 115 | 444 | 199 | 170 | 245 | 235 | 15 |
| VKA476AH-e | | 140 | 88 | 115 | 464 | 219 | 190 | 245 | 235 | 15 |
| VKA486AH-e | | 140 | 88 | 115 | 484 | 239 | 210 | 245 | 235 | 15 |
| VKA496AH-e | | 140 | 88 | 115 | 504 | 259 | 230 | 245 | 235 | 15 |
| VKA556AH-e | | 157 | 95 | 122 | 444 | 179 | 150 | 265 | 242 | 19 |
| VKA566AH-e | | 157 | 95 | 122 | 464 | 199 | 170 | 265 | 242 | 19 |
| VKA576AH-e | | 157 | 95 | 122 | 484 | 219 | 190 | 265 | 242 | 19 |
| VKA586AH-e | | 157 | 95 | 122 | 504 | 239 | 210 | 265 | 242 | 19 |
| VKA596AH-e | | 157 | 95 | 122 | 524 | 259 | 230 | 265 | 242 | 20 |
| VKA666AH-e | | 157 | 95 | 122 | 464 | 199 | 170 | 265 | 242 | 19 |
| VKA676AH-e | | 157 | 95 | 122 | 484 | 219 | 190 | 265 | 242 | 19 |
| VKA686AH-e | | 157 | 95 | 122 | 504 | 239 | 210 | 265 | 242 | 20 |
| VKA696AH-e | | 157 | 95 | 122 | 524 | 259 | 230 | 265 | 242 | 20 |
| VKA776AH-e | 157 | 95 | 122 | 484 | 219 | 190 | 265 | 242 | 19 | |
| VKA786AH-e | 157 | 95 | 122 | 504 | 239 | 210 | 265 | 242 | 20 | |
| VKA796AH-e | 157 | 95 | 122 | 524 | 259 | 230 | 265 | 242 | 20 | |
| VKA886AH-e | - | - | - | 544 | 239 | 210 | - | - | 25 | |
| VKA896AH-e | - | - | - | 564 | 259 | 230 | - | - | 25 | |
| VKA996AH-e | - | - | - | 564 | 259 | 230 | - | - | 25 | |

• Models VKA-AQ-e

Unit: mm

| Model | Fig. | D | KE | L | LH | LK | LL | W | Estimated mass (kg) |
|------------|------|-----|-----|-----|-----|-----|-----|-----|---------------------|
| VKA126AQ-e | 1 | 140 | 88 | 382 | 137 | 108 | 245 | 235 | 15 |
| VKA136AQ-e | | 140 | 88 | 410 | 165 | 138 | 245 | 235 | 15 |
| VKA146AQ-e | | 140 | 88 | 438 | 193 | 164 | 245 | 235 | 15 |
| VKA156AQ-e | | 140 | 88 | 466 | 221 | 192 | 245 | 235 | 15 |
| VKA166AQ-e | | 140 | 88 | 494 | 249 | 220 | 245 | 235 | 16 |
| VKA226AQ-e | | 140 | 88 | 382 | 137 | 108 | 245 | 235 | 14 |
| VKA236AQ-e | | 140 | 88 | 410 | 165 | 136 | 245 | 235 | 14 |
| VKA246AQ-e | | 140 | 88 | 438 | 193 | 164 | 245 | 235 | 14 |
| VKA256AQ-e | | 140 | 88 | 466 | 221 | 192 | 245 | 235 | 14 |
| VKA266AQ-e | | 140 | 88 | 494 | 249 | 220 | 245 | 235 | 15 |
| VKA276AQ-e | | 140 | 88 | 522 | 277 | 248 | 245 | 235 | 15 |
| VKA286AQ-e | | 140 | 88 | 550 | 305 | 276 | 245 | 235 | 15 |
| VKA296AQ-e | | 140 | 88 | 578 | 333 | 304 | 245 | 235 | 15 |
| VKA336AQ-e | | 157 | 96 | 430 | 165 | 136 | 265 | 242 | 18 |
| VKA346AQ-e | | 157 | 96 | 458 | 193 | 164 | 265 | 242 | 19 |
| VKA356AQ-e | | 157 | 96 | 486 | 221 | 192 | 265 | 242 | 19 |
| VKA366AQ-e | | 157 | 96 | 514 | 249 | 220 | 265 | 242 | 19 |
| VKA446AQ-e | | 157 | 96 | 458 | 193 | 164 | 265 | 242 | 19 |
| VKA456AQ-e | | 157 | 96 | 486 | 221 | 192 | 265 | 242 | 19 |
| VKA466AQ-e | | 157 | 96 | 514 | 249 | 220 | 265 | 242 | 19 |
| VKA476AQ-e | 157 | 96 | 542 | 277 | 248 | 265 | 242 | 19 | |
| VKA486AQ-e | 157 | 96 | 570 | 305 | 276 | 265 | 242 | 20 | |
| VKA496AQ-e | 157 | 96 | 598 | 333 | 304 | 265 | 242 | 20 | |
| VKA556AQ-e | - | - | 526 | 221 | 192 | - | - | 24 | |
| VKA566AQ-e | - | - | 554 | 249 | 220 | - | - | 24 | |
| VKA666AQ-e | - | - | 554 | 249 | 220 | - | - | 25 | |
| VKA676AQ-e | - | - | 582 | 277 | 248 | - | - | 25 | |
| VKA686AQ-e | - | - | 610 | 305 | 276 | - | - | 25 | |
| VKA696AQ-e | - | - | 638 | 333 | 304 | - | - | 25 | |

• Models VKC-AH-e

Unit: mm

| Model | Fig. | D | KE | KL | L | LH | LK | LL | W | Estimated mass (kg) |
|------------|------|-----|-----|-----|-----|-----|-----|-----|-----|---------------------|
| VKC136AH-e | 3 | 140 | 88 | 115 | 384 | 139 | 110 | 245 | 235 | 15 |
| VKC146AH-e | | 140 | 88 | 115 | 404 | 159 | 130 | 245 | 235 | 15 |
| VKC156AH-e | | 140 | 88 | 115 | 424 | 179 | 150 | 245 | 235 | 15 |
| VKC166AH-e | | 140 | 88 | 115 | 444 | 199 | 170 | 245 | 235 | 15 |
| VKC236AH-e | | 140 | 88 | 115 | 384 | 139 | 110 | 245 | 235 | 15 |
| VKC246AH-e | | 140 | 88 | 115 | 404 | 159 | 130 | 245 | 235 | 15 |
| VKC256AH-e | | 140 | 88 | 115 | 424 | 179 | 150 | 245 | 235 | 15 |
| VKC266AH-e | | 140 | 88 | 115 | 444 | 199 | 170 | 245 | 235 | 16 |
| VKC276AH-e | | 140 | 88 | 115 | 464 | 219 | 190 | 245 | 235 | 16 |
| VKC286AH-e | | 140 | 88 | 115 | 484 | 239 | 210 | 245 | 235 | 16 |
| VKC296AH-e | | 140 | 88 | 115 | 504 | 259 | 230 | 245 | 235 | 16 |
| VKC336AH-e | | 140 | 88 | 115 | 384 | 139 | 110 | 245 | 235 | 14 |
| VKC346AH-e | | 140 | 88 | 115 | 404 | 159 | 130 | 245 | 235 | 14 |
| VKC356AH-e | | 140 | 88 | 115 | 424 | 179 | 150 | 245 | 235 | 14 |
| VKC366AH-e | | 140 | 88 | 115 | 444 | 199 | 170 | 245 | 235 | 15 |
| VKC376AH-e | | 140 | 88 | 115 | 464 | 219 | 190 | 245 | 235 | 15 |
| VKC386AH-e | | 140 | 88 | 115 | 484 | 239 | 210 | 245 | 235 | 15 |
| VKC396AH-e | | 140 | 88 | 115 | 504 | 259 | 230 | 245 | 235 | 15 |
| VKC446AH-e | | 140 | 88 | 115 | 404 | 159 | 130 | 245 | 235 | 14 |
| VKC456AH-e | | 140 | 88 | 115 | 424 | 179 | 150 | 245 | 235 | 14 |
| VKC466AH-e | | 140 | 88 | 115 | 444 | 199 | 170 | 245 | 235 | 15 |
| VKC476AH-e | | 140 | 88 | 115 | 464 | 219 | 190 | 245 | 235 | 15 |
| VKC486AH-e | | 140 | 88 | 115 | 484 | 239 | 210 | 245 | 235 | 15 |
| VKC496AH-e | | 140 | 88 | 115 | 504 | 259 | 230 | 245 | 235 | 15 |
| VKC556AH-e | | 157 | 95 | 122 | 444 | 179 | 150 | 265 | 242 | 19 |
| VKC566AH-e | | 157 | 95 | 122 | 464 | 199 | 170 | 265 | 242 | 19 |
| VKC576AH-e | | 157 | 95 | 122 | 484 | 219 | 190 | 265 | 242 | 19 |
| VKC586AH-e | | 157 | 95 | 122 | 504 | 239 | 210 | 265 | 242 | 19 |
| VKC596AH-e | | 157 | 95 | 122 | 524 | 259 | 230 | 265 | 242 | 20 |
| VKC666AH-e | | 157 | 95 | 122 | 464 | 199 | 170 | 265 | 242 | 19 |
| VKC676AH-e | | 157 | 95 | 122 | 484 | 219 | 190 | 265 | 242 | 19 |
| VKC686AH-e | | 157 | 95 | 122 | 504 | 239 | 210 | 265 | 242 | 20 |
| VKC696AH-e | | 157 | 95 | 122 | 524 | 259 | 230 | 265 | 242 | 20 |
| VKC776AH-e | 157 | 95 | 122 | 484 | 219 | 190 | 265 | 242 | 19 | |
| VKC786AH-e | 157 | 95 | 122 | 504 | 239 | 210 | 265 | 242 | 20 | |
| VKC796AH-e | 157 | 95 | 122 | 524 | 259 | 230 | 265 | 242 | 20 | |

• Models VKC-AQ-e

Unit: mm

| Model | Fig. | D | KE | KL | L | LH | LK | LL | W | Estimated mass (kg) |
|------------|------|-----|----|-----|-----|-----|-----|-----|-----|---------------------|
| VKC126AQ-e | 3 | 140 | 88 | 115 | 382 | 137 | 108 | 245 | 235 | 15 |
| VKC136AQ-e | | 140 | 88 | 115 | 410 | 165 | 138 | 245 | 235 | 15 |
| VKC146AQ-e | | 140 | 88 | 115 | 438 | 193 | 164 | 245 | 235 | 15 |
| VKC156AQ-e | | 140 | 88 | 115 | 466 | 221 | 192 | 245 | 235 | 15 |
| VKC166AQ-e | | 140 | 88 | 115 | 494 | 249 | 220 | 245 | 235 | 16 |
| VKC226AQ-e | | 140 | 88 | 115 | 382 | 137 | 108 | 245 | 235 | 14 |
| VKC236AQ-e | | 140 | 88 | 115 | 410 | 165 | 136 | 245 | 235 | 14 |
| VKC246AQ-e | | 140 | 88 | 115 | 438 | 193 | 164 | 245 | 235 | 14 |
| VKC256AQ-e | | 140 | 88 | 115 | 466 | 221 | 192 | 245 | 235 | 14 |
| VKC266AQ-e | | 140 | 88 | 115 | 494 | 249 | 220 | 245 | 235 | 15 |
| VKC336AQ-e | | 157 | 95 | 122 | 430 | 165 | 136 | 265 | 242 | 18 |
| VKC346AQ-e | | 157 | 95 | 122 | 458 | 193 | 164 | 265 | 242 | 19 |
| VKC356AQ-e | | 157 | 95 | 122 | 486 | 221 | 192 | 265 | 242 | 19 |
| VKC366AQ-e | | 157 | 95 | 122 | 514 | 249 | 220 | 265 | 242 | 19 |
| VKC446AQ-e | | 157 | 95 | 122 | 458 | 193 | 164 | 265 | 242 | 19 |
| VKC456AQ-e | | 157 | 95 | 122 | 486 | 221 | 192 | 265 | 242 | 19 |
| VKC466AQ-e | | 157 | 95 | 122 | 514 | 249 | 220 | 265 | 242 | 19 |

2.7 Internal structure drawing

(1) Models VKA-AH-e (VKA1□6AH-e to VKA7□6AH-e)

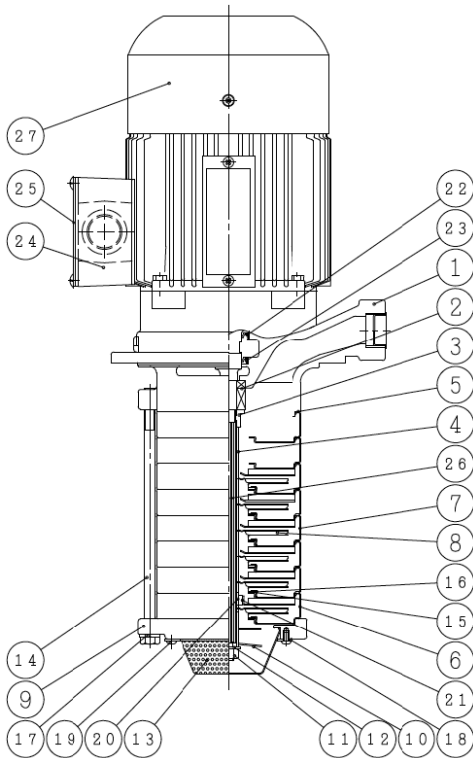

| Code | Part name | Material |
|------|--------------------------------|-------------|
| 1 | Pump leg | FC150 |
| 2 | Mechanical seal | SIC/SIC |
| 3 | Washer | SUS304 |
| 4 | Collar | SUS304 |
| 5 | Teflon packing | PTFE |
| 6 | Casing (without guide blade) | SUS304 |
| 7 | Casing (with guide blade) | SUS304 |
| 8 | Impeller | SUS304 |
| 9 | Suction chamber | FC150 |
| 10 | Screw | SUS304 |
| 11 | U-nut | SUS304 |
| 12 | Washer | SUS304 |
| 13 | Wide strainer | SUS304 |
| 14 | Tie bolt | SUS304 |
| 15 | Seal ring | PTFE |
| 16 | Metal presser | SUS304 |
| 17 | Spring washer | SUS304 |
| 18 | Strainer presser plate | SUS304 |
| 19 | Cross-recessed pan head screw | SUS304 |
| 20 | Sleeve ^{Note 1} | WC |
| 21 | Bearing ring ^{Note 1} | CERAMIC |
| 22 | Oil seal | NBR |
| 23 | Oil seal | NBR |
| 24 | Terminal Box | ADC |
| 25 | Terminal box cover | SS400 |
| 26 | Motor shaft | S35C+SUS403 |
| 27 | Motor | - |

Note 1) A pump with six or fewer casing stages does not come with the sleeve and bearing ring.

(2) Models VKA-AH-e /VKC-AH-e (VKA8□6AH-e, VKA9□6AH-e, all VKC-AH-e models)

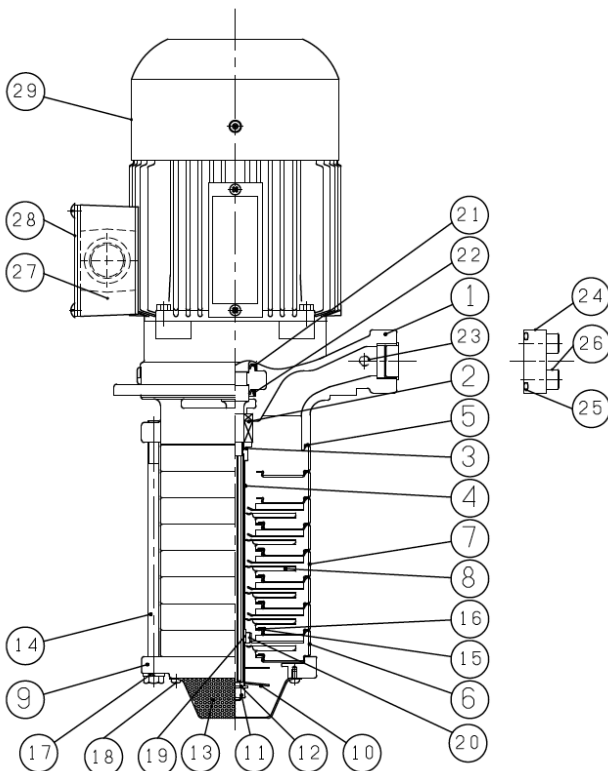

| Code | Part name | Material | |
|------|--------------------------------|--------------|--------------|
| | | VKA-AH model | VKC-AH model |
| 1 | Pump leg | FC150 | SCS14A |
| 2 | Mechanical seal | SIC/SIC | SIC/SIC |
| 3 | Washer | SUS304 | SUS304 |
| 4 | Collar | SUS304 | SUS304 |
| 5 | Teflon packing | PTFE | PTFE |
| 6 | Casing (without guide blade) | SUS304 | SUS304 |
| 7 | Casing (with guide blade) | SUS304 | SUS304 |
| 8 | Impeller | SUS304 | SUS304 |
| 9 | Suction chamber | FC150 | SCS14A |
| 10 | Screw | SUS304 | SUS304 |
| 11 | U-nut | SUS304 | SUS304 |
| 12 | Washer | SUS304 | SUS304 |
| 13 | Wide strainer | SUS304 | SUS304 |
| 14 | Tie bolt | SUS304 | SUS304 |
| 15 | Seal ring | PTFE | PTFE |
| 16 | Metal presser | SUS304 | SUS304 |
| 17 | Spring washer | SUS304 | SUS304 |
| 18 | Cross-recessed pan head screw | SUS304 | SUS304 |
| 19 | Sleeve ^{Note 1} | WC | WC |
| 20 | Bearing ring ^{Note 1} | CERAMIC | CERAMIC |
| 21 | Oil seal | NBR | NBR |
| 22 | Oil seal | NBR | NBR |
| 23 | Air vent | Brass | SUS304 |
| 24 | Companion flange | FC150 | SCS16A |
| 25 | Oil seal | FKM | FKM |
| 26 | Hexagon socket head cap screw | SCM | SUS304 |
| 27 | Terminal Box | ADC | ADC |
| 28 | Terminal box cover | SS400 | SS400 |
| 29 | Motor | - | - |

These figures use a typical model. Some parts vary in shape depending on the model and specifications. Because some of the specifications may be changed due to design changes or for other reasons, please request the delivery specifications when implementing your plan.

(3) Models VKA-AQ-e (VKA1□6AQ-e to VKA4□6AQ-e)

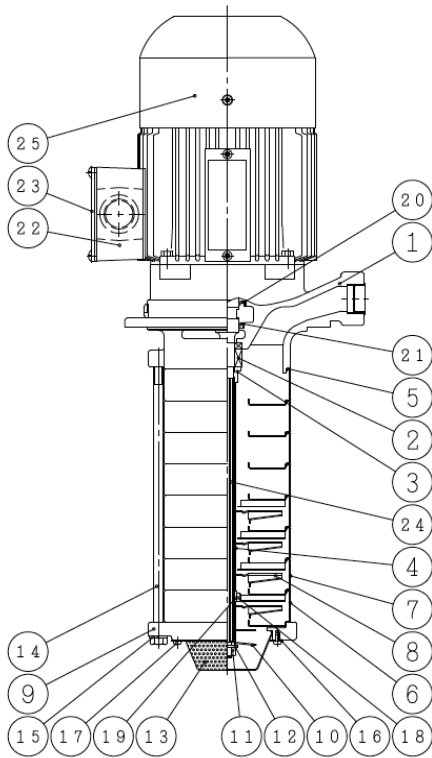

| Code | Part name | Material |
|------|--------------------------------|-------------|
| 1 | Pump leg | FC150 |
| 2 | Mechanical seal | SIC/SIC |
| 3 | Washer | SUS304 |
| 4 | Collar | SUS304 |
| 5 | Teflon packing | PTFE |
| 6 | Casing (without guide blade) | SUS304 |
| 7 | Casing (with guide blade) | SUS304 |
| 8 | Impeller | SUS304 |
| 9 | Suction chamber | FC200 |
| 10 | Screw | SUS304 |
| 11 | U-nut | SUS304 |
| 12 | Washer | SUS304 |
| 13 | Wide strainer | SUS304 |
| 14 | Tie bolt | SUS304 |
| 15 | Spring washer | SUS304 |
| 16 | Strainer presser plate | SUS304 |
| 17 | Cross-recessed pan head screw | SUS304 |
| 18 | Bearing ring ^{Note 1} | CERAMIC |
| 19 | Sleeve ^{Note 1} | WC |
| 20 | Oil seal | NBR |
| 21 | Oil seal | NBR |
| 22 | Terminal Box | ADC |
| 23 | Terminal box cover | SS400 |
| 24 | Motor shaft | S35C+SUS403 |
| 25 | Motor | - |

(4) Models VKA-AQ-e /VKC-AQ-e (VKA5□6AQ-e to VKA6□6AQ-e, all VKC-AQ-e models)

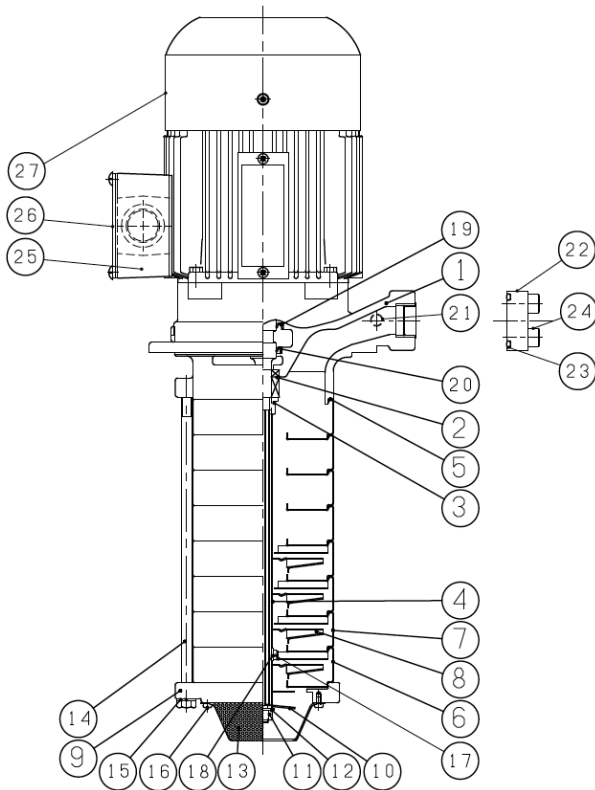

| Code | Part name | Material | |
|------|--------------------------------|--------------|--------------|
| | | VKA-AH model | VKC-AH model |
| 1 | Pump leg | FC150 | SCS14A |
| 2 | Mechanical seal | SIC/SIC | SIC/SIC |
| 3 | Washer | SUS304 | SUS304 |
| 4 | Collar | SUS304 | SUS304 |
| 5 | Teflon packing | PTFE | PTFE |
| 6 | Casing (without guide blade) | SUS304 | SUS304 |
| 7 | Casing (with guide blade) | SUS304 | SUS304 |
| 8 | Impeller | SUS304 | SUS304 |
| 9 | Suction chamber | FC200 | SCS14A |
| 10 | Screw | SUS304 | SUS304 |
| 11 | U-nut | SUS304 | SUS304 |
| 12 | Washer | SUS304 | SUS304 |
| 13 | Wide strainer | SUS304 | SUS304 |
| 14 | Tie bolt | SUS304 | SUS304 |
| 15 | Spring washer | SUS304 | SUS304 |
| 16 | Cross-recessed pan head screw | SUS304 | SUS304 |
| 17 | Bearing ring ^{Note 1} | CERAMIC | CERAMIC |
| 18 | Sleeve ^{Note 1} | WC | WC |
| 19 | Oil seal | NBR | NBR |
| 20 | Oil seal | NBR | NBR |
| 21 | Air vent | Brass | SUS304 |
| 22 | Companion flange | FC150 | SCS16A |
| 23 | O-ring | FKM | FKM |
| 24 | Hexagon socket head cap screw | SCM | SUS304 |
| 25 | Terminal Box | ADC | ADC |
| 26 | Terminal box cover | SS400 | SS400 |
| 27 | Motor | - | - |

These figures use a typical model. Some parts vary in shape depending on the model and specifications. Because some of the specifications may be changed due to design changes or for other reasons, please request the delivery specifications when implementing your plan.

3. Transportation, conveyance, storage and installation

3.1 Precautions for transporting, moving and storing the pump

- (1) Do not unpack the container unnecessarily.
If you unpack the container unnecessarily, securely pack again in such a manner that the product body does not jump out of it and fall down during transportation, conveyance or storage.
- (2) When you transport, move, or store the pump, ensure that the pump is located in a well-ventilated place with minimum exposure to dust and moisture in an environment at an ambient temperature of -25 to 55 degrees Celsius and humidity of less than 85%RH. The packing materials, made mainly of corrugated cardboards, break more easily when they absorb moisture.
- (3) Check the orientation of the container and then place it in the correct orientation (not upside down).
- (4) Do not stack the containers of the product more than the allowable number of units indicated on the packing material.
The maximum permissible number of stacks for this product is three.
- (5) Use extreme care so as not to give an impact or offset load to the pump during conveyance or transportation. The container may greatly incline depending on its center of gravity.



Before transporting or moving the product, confirm the weight of each unit by referring to the catalog, dimensional outline drawing, and other documents, and then determine the appropriate method.



When you lift the product by hand, pay attention to its center of gravity and weight. Do not allow a single person to lift a product heavier than 15 kg. Otherwise, it may put strain on the body, thus leading to an injury.

3.2 Before using the pump

When you receive the pump, check the following points first.

If there are any problems, contact the vendor from which you purchased the product.



Ensure that the delivered container is placed in the correct orientation (not upside down) before unpacking. Pay special attention to nails especially when opening a wooden crate. Otherwise, you may get injured.

- (1) Check the nameplate to verify that the delivered product is exactly what you ordered. (Refer to 2.4. Information indicated on the nameplates [page 2-3].)
- (2) No part of the product is damaged during transportation.
- (3) All fastening parts including bolts and nuts are securely tightened.
- (4) All the accessories that you ordered have been delivered.



Do not hold the strainer on the tip of the pump during handling. Failure to observe this may cause the strainer to come off, resulting in an injury or damage.



Do not run the pump at a frequency exceeding 60 Hz. Failure to observe this may overload the motor, causing it to burn out.

3.3 Precautions for installation



Before rotating the main shaft by hand to check it, be sure to turn off the main power. Sudden operation of the pump may cause an accident.

- (1) Install the product in a well-ventilated place with minimum exposure to dust and moisture. (Refer to the Installation location in 2.3. Standard specifications [page 2-2]). In particular, avoid installing the product in a place where the liquid used is splashed on the motor section.



Do not install the product in a place exposed to high temperature and moisture.
Failure to observe this may cause heating, ignition and electric leakage.

- (2) Install the product in such a way that the motor can take in air.
- (3) Select a flat place for the mounting surface and then install the product so as not to rattle.
- (4) Select a place convenient for maintenance and inspection. Ensure maintenance clearances.
- (5) The mounting surface should be strong enough to prevent vibration from being amplified when the pump is running.
(Restrict the total amplitudes in X, Y and Z directions (see the right figure) to $33\mu\text{m}$ at 50 Hz and $29\mu\text{m}$ at 60 Hz during pump operation.)
- (6) It is necessary to make a mounting hole larger than the outside diameter of the pump section so as to put the pump section into the tank (oil tank). See the dimensional outline drawing.
- (7) Install the product so that the main shaft becomes vertical.
- (8) Use the product with the pump section immersed under the oil level.
The suction port should be at least 5 mm away from the bottom surface of the tank (oil tank) to prevent the strainer from getting clogged with cutting powder, dirt, or other materials. If it is predicted that cutting powder, dirt, or other materials accumulate on the bottom of the tank, ensure as large a distance as possible at the design stage.

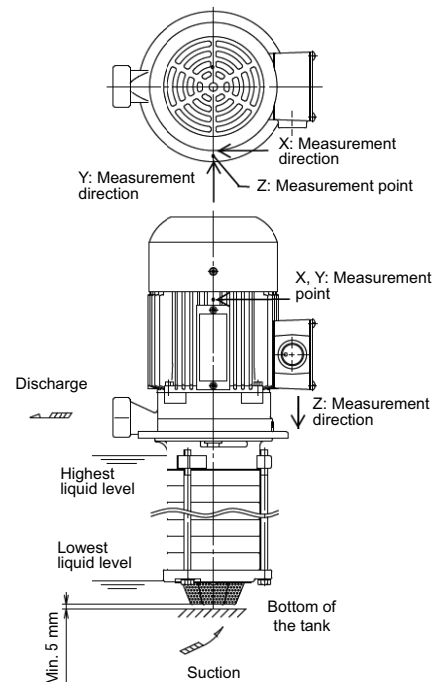

Note

The liquid level in the tank (oil tank) should always be above the minimum liquid level.
Keep the suction port of the pump at least 5 mm away from the bottom of (oil tank).

- (9) The product is coated, but if it is overcoated to another color for unavoidable reasons, lightly roughen the product surface with sand paper and then coat it. The adhesion properties of the coating film are improved. (Be sure to check that a paint to be used is applicable to overcoating.)
- (10) When the liquid leaks from the product, install it in a place where it is not subjected to secondary damage.

- (11) If the system could be exposed to the freezing temperature in winter, be sure to apply antifreeze measures such as heat insulation and heater installation to the pump, valves, piping, etc.
- (12) Install the pump securely.
Recommended size of pump mounting bolt: M6

Note

Securely tighten the bolts. Otherwise, it may cause abnormal vibration or other problems.

- (13) To lift the pump, install an eyenut and a hexagon head bolt at two (diagonally-located) mounting holes of the pump, and pass a rope etc. through the eyenuts.
Eyenut size: M6,
Bolt size: M6 x 20L (nominal length [length below the head]: 20 mm)

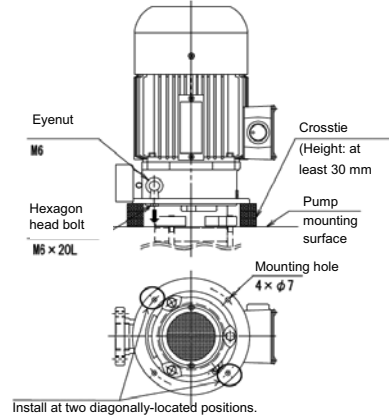

- (14) Before installing the pump to equipment, place crossties (with a height enough for the hexagon head bolts to be removed) between the pump flange surface and pump mounting surface as shown in the right figure, and remove the eyenuts and hexagon head bolts installed for lifting. Afterwards, pull out the crossties and install the pump.

Warning ⚠️ ⚡

When installing the pump, do not put your hands between the pump flange and the pump mounting surface. Failure to observe this may cause an injury.

- (15) Do not lift the equipment with the pump attached. Failure to observe this may cause the units to break and fall down.
- (16) Use extreme care so as not to give an impact or offset load to the pump section during pump lifting or conveyance. The pump may greatly incline depending on its center of gravity.

Warning ⚠️ ⚡

Before hoisting the equipment, refer to the catalogue or dimensional outline drawing etc. and ensure that the total weight of the equipment does not exceed the rated load of the hoisting device.

Caution ⚠️

When lifting the product by hand, give attention to its center of gravity and weight. Do not allow any product heavier than 15 kg to be lifted by a single person. Failure to observe this may put a burden on the body, leading to an injury.

- (17) If the pumping liquid is cold, condensation may occur inside the motor while the pump is stopped. Take condensation prevention measures such as installing in a fully dry room or heating and insulating the motor during a stop.
- (18) Carry out refinish painting with a period appropriate to a use environment. Threaded parts, worked areas, coated parts for rust prevention and other parts may rust may depending on use environments such as high humidity and dew condensation.
- (19) Do not put a cover or a filter over the motor, or it may increase the temperature inside the motor and lead to damage, fire, etc. of the product.

3.4 Precautions for piping work

- (1) The pipes should be as short and straight as possible (with minimal joints and valves). Use pipes whose bore size is equal to or larger than that of the pump. Piping which is thin and has many bends may decrease the discharge rate.
- (2) Be sure to provide pipe supports so as to prevent the weight of the pipes from acting on the pump body.



Avoid the weight of the pipes from acting on the pump.
Failure to observe this may cause the main shaft from coming off center, resulting in equipment damage, vibration and noise.

- (3) Do not forcibly screw the pipe into the pump. Doing so may break the joint.
- (4) Lay the pipes securely in such a way that the pipe connections are kept completely airtight without leakage. Prevent liquid leakage and air leakage by use of seal tape, liquid packing or other means. The seal tape should be wound reliably so as not to block up the piping.
- (5) Use a tank (oil tank) with as larger a capacity as possible.
* A recommended capacity is at least three times the discharge volume per minute.
Too small a capacity may cause problems such as causing the liquid temperature to rise up, causing the strainer to get clogged with cutting powder, and causing the discharge rate to decrease due to the occurrence of air bubbles.
When pouring a liquid used into a tank (oil tank), slowly pour air so as not to trap air in.
- (6) Do not allow a large amount of cutting powder, dirt, or other contaminants to get into the pump section. Failure to observe this may clog the pump strainer, damage the pump, or significantly deteriorate the performance. Use liquids that are subjected to secondary treatment through a net cage, a chip conveyor, a magnetic separator, etc.
- (7) If water hammer may occur, attach a pressure damper (e.g. accumulator).
- (8) The companion flange type pump is packaged with a companion flange for the discharge port. Use it as needed. When using the flange, be sure to install the supplied O-ring.
- (9) If there is an upward curve of the discharge pipe, ensure that air can be vented from the section.
- (10) If you provide an escape pipe on the pump discharge side, provide a sluice valve in the middle of the escape pipe to adjust the relief volume.

Note

If the amount released from the escape pipe is too much, the temperature of the liquid in the tank (oil tank) comes to rise easily.

- (11) On completion of the piping work, clean the inside of the tank (oil tank) to prevent the suction of foreign matter.

3.5 Precautions for wiring work



Use high-quality wiring equipment and devices, and carry out wiring work safely and securely according to the technical standards for electrical facilities, as well as the indoor wiring regulations.
Only qualified personnel such as licensed electrical engineers are allowed to carry out electrical wiring work. Unqualified persons are prohibited by law to carry out wiring work, and it is very dangerous.



Securely connect the terminals of the power cable. Loose terminals may cause an open phase fault, which causes the motor to burn out.

- (1) For the size of the power cable, refer to the following:

| Model | Minimum size of the cable (200-volt class) |
|------------|---|
| All models | 1.6mm |

- (2) Be sure to install a ground fault interrupter and an overload protection device on the primary power side of the pump.

* The starting current of the top runner efficiency (IE3) motor-equipped product tends to become higher than that of the standard efficiency (IE1) motor-equipped product. Therefore, it is necessary to apply and verify an earth leakage circuit breaker and overload protection device on the occasion of replacement from the IE1 motor-equipped product.

Refer to Starting current value and Rated current value in “2.5. Specification table (page 2-4).” If you have any questions, contact Teral Inc.

Note

It is necessary to apply and verify a protective device on the primary side of the pump on the occasion of replacement from the IE1 motor-equipped product.
If not applied, the protective device may operate at the time of startup.

- (3) When connecting to terminals, securely connect to the power according to the right figure. (Standard voltage product)
* If there are four or more terminals, follow the connection nameplate in the terminal box.
- (4) Be sure to attach a ground wire to prevent an electric shock. Connect the ground wire to the ground terminal inside the control panel.

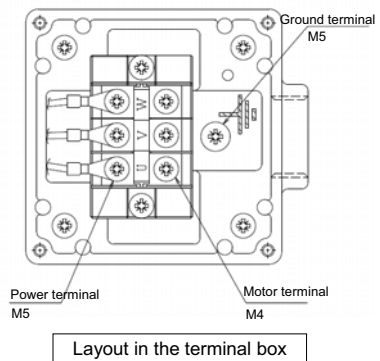

Connecting a ground wire to gas or water pipes is illegal and extremely dangerous.

- (5) Fasten the power cable to the terminal box with a cable lock so that no tensile load acts on the motor terminal block.
- (6) The position of the terminal box relative to the discharge port can be changed in steps of 90 degrees by rearranging the frame of the motor.

If you rearrange the frame of the motor, ask Teral Inc. about the operating procedures.

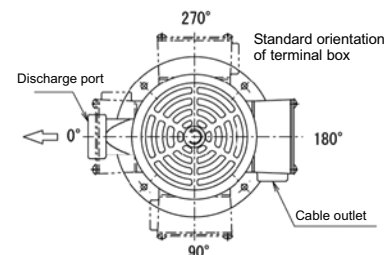

Do not change the orientation of the terminal box. Failure to observe this may cause the liquid to get into the terminal box, thus imparting an electric shock.

- (7) To prevent the motor from being overloaded and burned out, it is recommended to use a thermal relay for motor protection.
- (8) Carry out adequate dust-proofing and drip-proofing by a connector or gland so that cutting powder and liquid coolant do not get into the terminal box through the external wiring hole.

- (9) Pass the power cable through a metal tube or a metal conduit for shielding, and connect a ground wire to the outer surface of the tube.
- (10) Limit the fluctuations of the supply voltage within $\pm 10\%$ of the rated voltage, and also limit the fluctuations of the frequency within -5% to $+3\%$ of the rated value. Although you can run the pump in these ranges, avoid continuous operation if the voltage is not within the range of $\pm 5\%$ of the rated value or if the frequency is not within the range of $\pm 2\%$ of the rated value. Failure to observe this may cause the pump to be overloaded, resulting in motor damage or a fire. Even if the power fluctuations fall within the allowable ranges, the pump characteristics, motor characteristics, and the temperature rise of the motor may differ from those at the rated voltage and frequency.
- (11) Precautions for using the inverter drive
- Ensure that the operation current value does not exceed 90% of the rated value.
 - Ensure that the minimum frequency is set to 20 Hz.
(Contact us for operation at 20 Hz or below.)
 - If the motor is powered at a different voltage, it cannot be inverter-driven. (If it is necessary to use the motor with an inverter, contact Teral Inc.)
 - An inverter-driven motor generates a magnetic sound which may sound more annoying than those generated by the drives using unconverted commercial power.
 - Although this magnetic sound does not cause an adverse effect on the quality of the motor, some inverters allow the user to adjust the tone by changing the carrier frequency. However, changing the frequency may reduce the allowable output of the inverter. Pay particular attention when selecting the inverter.
 - If the pump and motor produce resonance during normal operation, do not run them in the range of the rotation speed.



Do not run the pump at a frequency exceeding 60 Hz. Failure to observe this may overload the motor, causing it to burn out.

4. Operation

4.1 Check items before test operation

4.1.1 Check items related to the electrical system

- (1) Check that the equipment is correctly wired.
- (2) Check that the terminals are securely connected.
- (3) Check that the equipment is securely grounded.
- (4) Check that the setup value of the overload protection device is consistent with the rated current value of the motor.



Do not use the product at any voltage other than the rated voltage. Otherwise, a fire or an electric shock may occur.

4.1.2 Check items related to the pump



Do not run the pump with its strainer removed. Failure to observe this may cause an injury or damage.



Do not allow a large amount of foreign matter to get into the pump. Failure to observe this may cause damage to the sliding parts (e.g. mechanical seals and bearings) inside the pump, leakage, or unusual noise.

- (1) Ensure that the oil level in the tank (oil tank) is above the "lowest oil level" position.

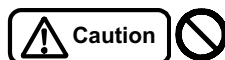

During test operation, never run the pump dry (i.e. never run the pump when the liquid level is below the minimum level). During normal operation, do not run the pump dry for more than 30 seconds. Failure to observe this may cause the sliding parts (e.g. mechanical seals and bearings) inside the pump to seize up.

- (2) Check the rotational direction. Normal rotational direction is counterclockwise rotation when viewed from the motor side. (See the right figure.)
- (3) Rotate the main shaft by hand to check smooth rotation. To rotate the shaft by hand, insert a flat-blade screwdriver through the fan cover of the motor and turn its shaft. If the rotation is stiff or not uniform, there may be some rusting or foreign matter inside the pump. Inspect the pump in such a case.

Rotation direction

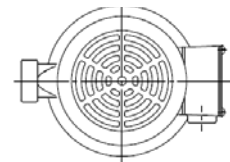



Before rotating the main shaft by hand to check it, be sure to turn off the main power. A sudden startup of the pump may cause an accident.

- (4) Open the air vent valve to release air. After the air release, close the air vent valve.

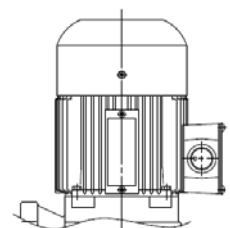
If no air vent valve is provided, open the valve on the discharge piping to release air.





- (5) If you run the pump while changing the speed with the inverter, ensure to check the following points through test operations.
- The pump may produce resonance depending on installation conditions. If the pump produces resonance, avoid that frequency.
 - If the operation frequency is low or the dynamic viscosity of the liquid is high, the pump may not discharge any liquid.
 - Do not run the pump at a frequency exceeding 60 Hz. Failure to observe this may cause the motor to burn out.

 **Caution** 

Do not run the pump at a frequency exceeding 60 Hz. Failure to observe this may overload the motor, causing it to burn out.





4.2 Running the pump (test operation)

 **Warning**  





Be sure to install the cover of the terminal box of the motor. Failure to observe this may cause an electric shock.

 **Warning** 

If you find any abnormal conditions during the check prior to test operation, do not run the pump with parts etc. under abnormal conditions. Failure to observe this may cause an injury, failure, accident, etc.



 **Warning**   

When the liquid used exceeds 40°C, do not touch the pump. Failure to observe this may cause the operator to suffer a burn due to high temperature of the pump.

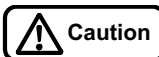

 **Warning**   

Do not touch the motor during operation or immediately after the stop of operation. Failure to observe this may cause the operator to suffer a burn due to high temperature of the pump.

- (1) Check the rotational direction of the pump by turning on and off the power switch once or twice. Normal rotational direction is counterclockwise rotation when viewed from the motor side. If the pump rotates reversely, replace two of the three wires of the power cable.

 **Caution** 

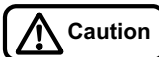
Do not check the rotational direction by the idling of the pump. Running the pump dry even for a short time may cause damage of the sliding parts (e.g. mechanical seals and bearings) in the pump, leakage or unusual noise.

 **Caution** 

Avoid reverse rotation because it may cause failures.



Do not run the pump dry, and do not allow air or a large amount of foreign matter to get into the pump. Failure to observe this may cause damage of the sliding parts (e.g. mechanical seals and bearings) in the pump, pumping disabled, leakage or unusual noise. Moreover, the pump heats up and causes the operator to suffer a burn. After installing the pump, release air through the air vent, and then supply liquid in the pump above the minimum level.

- (2) If the air vent valve is installed on the pump, slightly open the air vent valve at the time of startup, and confirm that the liquid is discharged. After the confirmation, close the air vent valve securely.
- (3) Turn on the power to start the pump.
- (4) Do not perform the zero-discharge operation. Failure to observe this may increase the liquid temperature in the pump and damage the mechanical seals. If the zero-discharge operation is not avoidable, allow a small amount of liquid to flow (3L/min), for example, by providing a bypass circuit. If you no longer use the liquid, stop the pump. If the liquid temperature rises to a certain level, it may reduce the service lives of the motor and pump parts.



Avoid running the pump in zero-discharge condition. Failure to observe this may increase the liquid temperature in the pump, resulting in an unexpected failure.

- (5) When initially circulating the liquid by pump operation, gradually open the sluice valve on the discharge side to perform circulation cleaning at the flow rate (flow velocity) used or higher.



Before restarting the pump, be sure to check that the pump has stopped completely. Turning on the power while the pump is still rotating causes an excessive torque on the pump and may cause failures.

- (6) Adjust the sluice valve on the discharge side to the specified pressure.
- (7) When the liquid level is too low, the pump may take air in and decrease the discharge rate, thus making it impossible to pump the liquid. Keep the liquid level above the minimum liquid level indicated in the outline drawing. Note that, however, this liquid level changes depending on viscosity and liquid surface condition. For safety, set the liquid level high enough, but at a level below the "maximum liquid level" indicated in the outline drawing.
- (8) Limit the startup and stop frequencies to 60 times per hour as a guide.



Minimize the frequency of startups and shutdowns of the pump as it may lead to premature damage to the pump. Do not start the pump more than 60 times an hour.

- (9) If a power failure occurs during operation, be sure to turn off the power.
- (10) Before restarting the pump, confirm that the pump is at a complete stop.



After power-off, do not restart the pump until it comes to a complete stop. Otherwise, an excessive load may act on the main shaft, resulting in shortened service life of the pump. Start the pump from a complete stop.

- (11) Avoid abrupt pressure fluctuations during pump operation.
- (12) Check for any abnormal pressure, current, vibration, noise, and other conditions. If you find any abnormal conditions, take appropriate action after examining the Section “6. Troubleshooting (page 6-1).”

Refer to the next page for vibration.

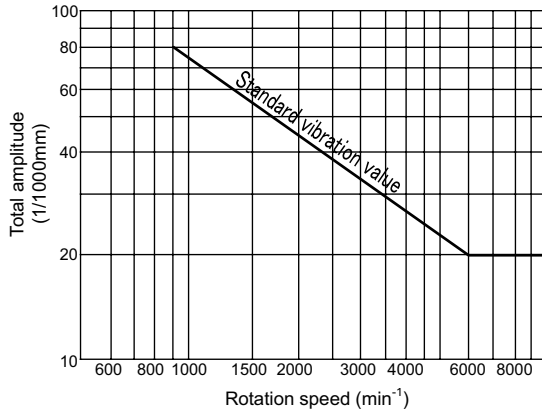

Standard vibration value at the bearing section

<Reference>

Relational expression between total amplitude a and vibration velocity V

$$a = \frac{V \times 6 \times 10^4}{\pi \times n}$$

- a: Total amplitude (μm)
- V: Vibration velocity (mm/s)
- n: Equipment rotation speed (min⁻¹)

- (13) Do not allow a large amount of cutting powder to get in the pump. Failure to observe this may clog the pump strainer, break the pump, or significantly deteriorate the performance. If you use the pump in the grinding process and other processes, e.g. milling and end milling, which discharge cutting powder, select a pump carefully. (Refer to Item (6) in Section “3.4. Precautions for piping work [page 3-4].”)
- (14) Stop the pump.



Keep the cocks of the pressure gauges and compound gauge closed except during measurement. Otherwise, they come to fail with ease.





Do not run the pump beyond the allowable current value, or the motor may burn out.





Do not put your fingers or other objects into the opening of the motor. Doing so may cause an electrical shock or injury.

5. Maintenance and inspection

Warning



Before checking the pump, be sure to turn off the main power.
Failure to observe this may lead to a danger because the pump may suddenly start in automatic operation or on other occasions.

Warning

Before operating, maintaining or checking the pump, ensure that all the relevant workers are informed of the operation and that there are no workers in the dangerous zone.

5.1 Precautions for maintenance and inspection

(1) When carrying out a daily inspection, carefully observe the following points

- ① A large deviation in the pump's discharge pressure, current, vibration, noise, or other conditions from the normal status is a sign of a failure. Therefore, take measures as soon as possible, referring to the maintenance check list in Section "5.4. Periodic inspection [page 5-3]."
For this purpose, it is recommended to keep an operation log.
- ② If the bearing temperature gets too high, immediately stop the pump and check the bearing. The temperature is normal when the difference between the motor surface temperature and the ambient temperature is not greater than 40°C.
- ③ Because shielded grease filled bearings are used, the bearings hardly require grease filling and other maintenance work. Replace the bearings if unusual noise and vibration are produced from them.

| Model | Bearing type | |
|--|--------------|---------------|
| | Load side | Non-load side |
| VKA1□6AH-e~VKA4□6AH-e, VKA1□6AQ-e~VKA2□6AQ-e VKC1□6AH-e~VKC4□6AH-e, VKC1□6AQ-e~VKC2□6AQ-e | 6304 ZZ C3 | 6203 ZZ C3 |
| VKA5□6AH-e~VKA7□6AH-e, VKA3□6AQ-e~VKA4□6AQ-e VKC5□6AH-e~VKC7□6AH-e, VKC3□6AQ-e~VKC4□6AQ-e | 6306 ZZ C3 | 6303 ZZ C3 |
| VKA8□6AH-e~VKA9□2AH-e, VKA5□6AQ-e~VKA6□6AQ-e | 6307 ZZ C3 | 6303 ZZ C3 |

* Long-life urea grease is used as lubricating grease in bearings. When you replace the parts, it is recommended to use a grease equivalent to the following:

- Bearings by NSK (EA2 grease)
- Bearings by NACHI (FNS3D grease)

- ④ The bearing section is mounted with an oil seal to prevent the entry of the liquid. When replacing the bearing, replace the oil seal with new one.
- ⑤ If any oil seal or V-ring is used, high-frequency sound (rubber squeak) may occasionally be generated. However, it is not a symptom of a pump failure. You can continue to use the pump with the same good quality.



| Model | Oil seal type | | |
|--|-----------------------------|-----------------------------------|---------------|
| | Load side (Pump section) | Load side (Bearing section) | Non-load side |
| VKA8□6AH-e~VKA9□2AH-e VKA5□6AQ-e~VKA6□6AQ-e | DS17355 | VC20356 | DS20305 |
| Any other models | DS17355 | DS20325 | DS20305 |

- ⑥ High-frequency sound (mechanical squeak) that may occasionally be generated from the shaft seal is not a symptom of a pump failure. You can continue to use the pump with the same good quality.
 - ⑦ Normally, water leakage hardly occurs at the mechanical seal of the shaft seal. If by any chance the water leakage becomes frequent, replace the seal.
 - ⑧ Keep the cocks of the pressure gauges and compound gauge closed at all times except when inspection is required.
 - ⑨ In the event of a power failure, be sure to turn off the power.
The pump suddenly starts on restoration of the power, which leads to a danger.
- (2) If you do not use the pump for a long time, observe the following points:
- ① To prevent possible freezing inside the pump in winter, be sure to take antifreeze measures such as heat insulation and heater installation to the pump or completely drain the pump.
 - ② The sliding surface of the mechanical seal may become stiff, which makes it difficult to rotate the shaft smoothly. Therefore, periodically run the pump to maintain smooth rotation.
Moreover, before running the pump, turn it by hand to check that the rotation is smooth.
 - ③ If you have a backup pump, run it from time to time to make it available for operation at any time.



Caution

If you do not use the pump for a long time, turn off the power for safety.
Otherwise, accumulated dust may cause heating or ignition.

Warning

Before checking the pump by turning it by hand, be sure to turn off the main power. A sudden startup of the pump may cause an accident.

5.2 Mechanical seal

- (1) The mechanical seal is a precise part for preventing water leakage from the clearance of the pump shaft. Carefully handle the seal to ensure the proper operation of the pump.
- (2) The mechanical seal is a consumable part. Replacement is estimated to be once a year or every 8000 hours of continuous operation. However, the service life differs depending on the nature of the water, the presence or absence of foreign matter, and the operating pressure..
- (3) If there is any water leakage at the mechanical seal, replace it.
 - 3-1 In the initial stage of pump operation, a small amount of initial leakage may occur until the sliding surfaces on the mechanical seal completely settle (or fit) into place.
In the case of an initial leakage, the leakage will stop after 10 to 20 hours of operation. The initial leakage is not caused by the mechanical seal failure if the leakage stops.
You can use the pump with ease.
 - 3-2 The mechanical seal may leak from the minute gap formed on the sliding surface even if the sliding surface is not rough and the pump is in a good condition but the boost pressure is applied at the time of stoppage of the pump. The slight leakage increases as the boost

pressure increases. This leakage amount is evaporate when the pump is running. However, when the pump is stopped, there is no sliding heat sufficient to generation compared to when the running, and the leaked liquid remains without evaporating.

This results in a visible leakage. Therefore, such small leaks are normal leaks and are not mechanical seal failures.

- (4) If the pump is not operated for a long period of time, the sliding surface of the mechanical seal may become stuck, making it difficult to rotate. Periodically operate the pump to prevent the mechanical seal from becoming stuck. In addition, rotate the shaft manually to check if it is stuck before driving.
- (5) High-frequency sounds (mechanical squeaks) may occur occasionally, but this is not a pump failure. Even if you use the pump as it is, there is no problem in the function of the pump.
- (6) The mechanical seal used in the product is suitable for the standard liquid quality.
- (7) When using a special liquid such as antifreeze or pure water, the sliding surface or rubber parts may be damaged. Contact your nearest sales office in advance.

5.3 Daily check

Check for any abnormal discharge pressure, current, vibration, noise, and other conditions at the time of startup and during operation.

5.4 Periodic inspection



If you need to carry out work that requires disassembly of the unit—such as replacement of parts, repairs, or inspection, ask the vendor or the service provider specified by the manufacturer, or Teral Inc. Improper work may lead to malfunctions or accidents.

- (1) Clean the dirt and oil deposited on the outside surface of the coolant pump.
- (2) Accumulated cutting powder in the tank (oil tank) may cause a pump failure. Clean the tank (oil tank) at regular intervals.
- (3) Check that the strainer of the pump is not clogged. If clogged, clean the strainer.



Clean the strainer on the pump suction side at regular intervals. A clogged strainer may cause pressure fluctuations, decrease in discharge rate, unusual noise, etc., which may lead to a pump failure.

- (4) For other inspection items, refer to the following maintenance check list.

Maintenance check list

| Item | Inspection point | Inspection item | Inspection method | Criterion (Reference page) | Inspection interval | | | | Consumables Timing of replacement (as a guide)* | |
|-----------------------|---|--|---------------------------|---|-----------------------|---------|-------------|--------|---|-----------------------|
| | | | | | Daily | Monthly | Half-yearly | Yearly | | |
| Ambient environment | Temperature | As per the range in the specifications | Measure | -20 to 40°C or less (2-2) | ✓ | | | | - | |
| | Humidity | | Measure | Less than 85% RH (2-2) | ✓ | | | | - | |
| | Dust, etc. | | Visual check | Free of dust or other contaminants | ✓ | | | | - | |
| Power | Power terminal block | Voltage | Measure | Specified voltage (2-2) | | | ✓ | | - | |
| | | Voltage fluctuation | Measure | Within the allowable range of voltage fluctuation (2-2) | | | ✓ | | - | |
| | | Loose screws | Retighten | No loose screws | | | | ✓ | - | |
| Pump and motor | Impeller | Clogging | Inspect after disassembly | No clogging | | | | ✓ | - | |
| | | Wear | Inspect after disassembly | No abnormal condition | | | | ✓ | When worn out | |
| | Around the main shaft | Smooth rotation | Rotate by hand | Rotation is not stiff and is uniform (4-1) | | | | ✓ | - | |
| | Bearing ² (Motor) | Heating | Touch | Not unusually hot (5-1) | | | | ✓ | 1 to 2 years | |
| | Mechanical seal | Leakage | Visual check | No leakage (5-1) | | ✓ | | | 1 year (8000-hour operation) | |
| | Submerged bearing (bearing ring and sleeve) | - | - | No abnormal condition | | | | ✓ | 1 to 2 years | |
| | Rubber parts | O-rings | - | - | - | | | | ✓ | Whenever disassembled |
| | | Oil seals, etc. | - | - | No abnormal condition | | | | ✓ | 1 to 2 years |
| | Others (screws etc.) | - | - | No abnormal condition | | | | | As needed | |
| | Appearance | Unusual noise, vibration | Listen Visual check | No abnormal condition | ✓ | | | | - | |
| Insulation resistance | Between the ground and each lead | Megger tester | 1 MΩ or more | | | | ✓ | - | | |

*1 The timing of replacement (as a guide) is not a guaranteed value. The useful life of parts varies depending on ambient environment and use conditions.

* Long-life urea grease is used as lubricating grease in bearings. When you replace the parts, it is recommended to use a grease equivalent to the following:

- Bearings by NSK (EA2 grease)
- Bearings by NACHI (FNS3D grease)

6. Troubleshooting

The following table lists causes of failures and their measures. In the event of a failure, however, you should carefully investigate the problem and ask the vendor to carry out any measures that are considered difficult.

| Problem | Cause (Reference page) | Measures (Reference page) | Operator * |
|--|---|--|------------|
| The pump does not start. | Wiring is disconnected or broken. | Check the wires and connections. Repair or replace. | Vendor |
| | The power fuse is blown. | Replace it with an appropriate fuse. | User |
| | Tripping of the thermal relay | Check the thermal relay. | User |
| | Poor connection or contact of power wires (3-4) | Check the wires and connections. | Vendor |
| | The power voltage is too low.(2-2) | Check the power voltage. Contact the power company. | User |
| | The motor has failed. (e.g. broken wire of the stator winding) | Repair at vendor's shop. Contact the vendor because disassembly and inspection are required. | Vendor |
| | Foreign matter is caught in the impeller. | Disassemble, clean, and repair. Contact the vendor because disassembly and inspection are required. | Vendor |
| | The bearing is rusty. (5-1) | Replace the bearing. (5-1) Contact the vendor because disassembly and inspection are required. | Vendor |
| Overload and overcurrent of the motor | The shaft seal part is sticking in place. | Check the shaft seal part. Contact the vendor because disassembly and inspection are required. | Vendor |
| | The voltage is too high or too low. | Check the power voltage. Contact the power company. | User |
| | The voltage is unbalanced. | | |
| | The stator winding is broken, shorted, and grounded. | Contact the vendor because disassembly and inspection are required. | Vendor |
| | The stator and rotor are in contact due to wear of the bearing. (5-1) | Replace the bearing. (5-1) Contact the vendor because disassembly and inspection are required. | Vendor |
| | Open-phase failure occurs. | Check the wires. | User |
| | The dynamic viscosity of the liquid used is too high. (2-2) | Use a liquid with low dynamic viscosity. | User |
| | The discharge rate is high. | Throttle the sluice valve to meet the specifications. | User |
| The pump starts, but cannot achieve the specified discharge rate and the specified head. | The rotating part is in contact with another part. | Contact the vendor because disassembly and inspection are required. | Vendor |
| | Lots of air bubbles are contained in the liquid used. | Avoid bubbling and the suction of air bubbles. | User |
| | The rotation direction is reverse. | Correct the wiring so that the direction is normal.(4-2) | User |
| | The piping loss is high. | Check the piping diameter, route and length. | User |
| | The piping is clogged up with foreign matter. | Remove the foreign matter, and check the connections. | User |

| Problem | Cause (Reference page) | Measures (Reference page) | Operator * |
|--|---|---|------------|
| The pump starts, but cannot achieve the specified discharge rate and the specified head. | The impeller is worn. | Replace the impeller. Contact the vendor because disassembly and inspection are required. | Vendor |
| | Foreign matter is accumulated on the impeller and in the casing. | Remove the foreign matter, and check the connections. Contact the vendor because disassembly and inspection are required. | Vendor |
| | The rotating speed is low. | Check with the tachometer. | User |
| | The sluice valve is closed. | Open the sluice valve. | User |
| | The piping is clogged up with foreign matter. | Check and clean the piping. | User |
| | The strainer in the suction port is clogged. | Check and clean the strainer. | User |
| | The suction port is exposed above the liquid level. (3-2) | Adjust the liquid level. | User |
| Overheat of bearing | The bearing is worn and damaged. (5-1) | Replace the bearing. (5-1) Contact the vendor because disassembly and inspection are required. | Vendor |
| | The grease is deteriorated. (5-1) | | |
| | Incorrect installation of the pump and the piping (3-2) | Check, and correctly install. | User |
| Unusual noise and unusual vibration of the pump | The bearing is worn and damaged. (5-1) | Replace the bearing. (5-1) Contact the vendor because disassembly and inspection are required. | Vendor |
| | The motor is in open-phase operation. | Check the wiring. | User |
| | The impeller is clogged with foreign matter, resulting in an imbalance. | Disassemble and check. Contact the vendor because disassembly and inspection are required. | Vendor |
| | Cavitation has occurred. | Contact the manufacturer and vendor. | User |
| | Incorrect installation of the pump and the piping (3-2) | Check, and correctly install. | User |
| | Abnormal noise from the shaft seal (mechanical seal) (3-2) | Disassemble and check. Contact the vendor because disassembly and inspection are required. | Vendor |
| An abnormal amount of water is leaking from the shaft seal. | Damage to the mechanical seal (5-1) | If the water leakage becomes large, it is necessary to replace the seal. Contact the vendor because disassembly and inspection are required. | Vendor |
| Water hammer occurs. | Hammering has occurred when the valve is opened and closed rapidly. | Provide a pressure damper (e.g. accumulator). | User |

* t is specified for reference because the range where the measure can be taken varies depending on the user.

Even for the above problems for which "User" is specified as the Operator, ask the vendor or contact Teral Inc. if you have any questions.

7. After-sales service



If you need to carry out work that requires disassembly of the unit—such as replacement of parts, repairs, or inspection, ask the vendor or the service provider specified by the manufacturer, or Teral Inc. Improper work may lead to malfunctions or accidents.

- For maintenance and repair of the pump you purchased, contact the vendor from which you purchased or Teral Inc.
- If you find any abnormal conditions of the pump in use, stop the pump operation immediately and then confirm the abnormal conditions. (Refer to Section “6. Troubleshooting [page 6-1].”) If your pump needs disassembly, inspection and repair, contact the vendor from which you purchased or Teral Inc. (Refer to the end of this document.)
- Never repair by yourself because it may pose a danger.
- When you contact the vendor, give the nameplate entries (e.g. pump type and serial number) and abnormal conditions.
- For the warranty, refer to "Limited warranties (page I)" on the opening page of this document.

If you have any questions about the product, contact the vendor from which you purchased or contact Teral Inc.

8. Disposal

8.1 Precautions for disposal

When detaching the pump from the equipment for disposal or replacement of the pump, be sure to turn off the mains power in advance.



Before detaching the pump, turn off the mains power without fail. Failure to observe this may lead to a danger because the pump may suddenly start in automatic operation or on other occasions.



When lifting the pump, pay attention to its center of gravity. Failure to observe this may cause the product to topple over or fall down, leading to an injury.

- (1) Drain the liquid from the tank (oil tank) so that the bottom of the pump is exposed above the liquid level.
- (2) Close the sluice valve on the discharge side and open the air vent valve of the pump to discharge the liquid from the pump.
- (3) Remove the wiring and piping. (For the layout in the terminal box, refer to “Section 3.5. Precautions for wiring work [page 3-4].”)
- (4) Remove the pump mounting bolts and lift the pump. (Refer to “Section 3.3. Precautions for installation [page 3-2].”)

Because the liquid remaining in the pump may flow out while the pump is removed or moved, take measures against it as needed.



Do not hold the strainer on the tip of the pump during handling. Failure to observe this may cause the strainer to come off, resulting in an injury or damage.

- (5) Dispose of the pump as industrial waste. Dispose of other parts according to your national and local laws and regulations, for example, by asking the specialized waste disposal contractor.

Note

Dispose of the pump as industrial waste.

Note

The packing materials that became unnecessary after installation and the lubricating oils and parts that became needless in maintenance, check and repair work should be disposed of according to the legal regulations and the regulations of the region where they are used, e.g. requesting the vendor to dispose of.

TERAL
TERAL INC.

Head Office

230, Moriwake, Miyuki-cho, Fukuyama-city, Hiroshima, 720-0003, Japan
Tel.+81-84-955-1111 Fax.+81-84-955-5777

www.teral.net