Coolant Pump

Model: LVS-KS

⚠ WARNING

Do not operate, service or inspect this pump until you have read and understood this manual.

Keep this manual in a safe place where it can be consulted at any time.

To : All mechanical Contractor

Make sure to supply copies of this manual to the customer's operator maintenance and inspection personnel.

Limited warranties

1. In the event of a failure or breakage under proper use of the product during the warranty period, equipment supplied by Teral Inc. shall be repaired or replaced free of charge within the scope of the relevant part, provided that such failure or breakage is attributable to inadequacy of the design or workmanship of the equipment.
The warranty period of this product shall be one year after the date of delivery.
2. The warranty mentioned in the above clause shall be only the mechanical warranty of the defective part, and shall not cover any expenses or other damage arising from the failure or breakage.
3. In the event of the following failures and breakage, the costs of the repairs shall be borne by the user.
 - (1) Failures and breakage attributable to equipment that was not delivered by Teral Inc.
 - (2) Failures and breakage after the expiration of the warranty period
 - (3) Failures and breakage caused by disasters or force majeure, such as fire, acts of God, or earthquakes
 - (4) Failures and breakage resulting from repairs or modifications made without the consent of Teral Inc.
 - (5) Failures and breakage when parts other than those designated by Teral Inc. are used
 - (6) Failures and breakage caused by use or storage outside the specification range
4. Teral Inc. shall not be liable for the damage caused by incorrect or reckless use of the pump. Cost and expenses incurred for sending engineer(s) in such a case shall be borne by the user.
5. If the cause of the failure is unclear, necessary actions shall be determined through mutual consultation.

<Paid repairs>

After the expiration of the warranty period, the costs of investigation and repairs related to the product shall be borne by the user. For any failures that have occurred within the warranty period but that fall outside the above-mentioned warranty coverage, Teral Inc. shall carry out repairs and investigation for a fee. Please give us the instructions to do so in such a case.

Purpose of this manual

The purpose of this manual is to provide the user with detailed information necessary to properly operate, maintain and inspect the pump. Incorrect operation of this product may lead to an unexpected accident.

Please use the product correctly according to this instruction manual.

This manual contains the following information and is intended for persons experienced in the operation of pumps, or for those who have been trained by such experienced operators. Only qualified personnel such as licensed electrical engineers are allowed to carry out the electrical wiring work.

Contents

	(Page)
Limited warranties	I
Purpose of this manual	II
Contents	II
1. Safety precautions	1-1
1.1 Types and meanings of warning terms and graphic symbols	1-1
1.2 Safety precautions	1-1
1.3 Location of warning labels and caution labels	1-4
2. Configuration and overview of the pump	2-1
2.1 Part names and functions	2-1
2.2 Naming rule of the model codes	2-1
2.3 Standard specifications	2-2
2.4 Information indicated on the nameplates	2-3
2.5 Specification table	2-4
2.6 Dimensional outline drawing and dimensions table	2-5
2.7 Internal structure drawing (Example)	2-13
3. Transportation, conveyance, storage and installation	3-1
3.1 Precautions for transportation, moving and storing the pump	3-1
3.2 Before using the pump	3-1
3.3 Precautions for installation	3-2
3.4 Precautions for piping work	3-4
3.5 Precautions for wiring work	3-5
4. Operation	4-1
4.1 Check items before test operation	4-1
4.1.1 Check items related to the electrical system	4-1
4.1.2 Check items related to the pump	4-1
4.2 Running the pump (test operation)	4-2
5. Maintenance and inspection	5-1
5.1 Precautions for maintenance and inspection	5-1
5.2 Tightening the coupling	5-2
5.3 Motor bearing and grease refilling	5-3
5.4 Daily inspection	5-3
5.5 Periodic inspection	5-4
6. Troubleshooting	6-1
7. After-sales service	7-1
8. Disposal	8-1
8.1 Precautions for disposal	8-1

1. Safety precautions

1.1 Types and meanings of warning terms and graphic symbols

This instruction manual divides precautions into the following four categories according to the level of hazards (or the severity of the accident). In addition, prohibited or mandatory actions as well as cautions are indicated with a graphic symbol.

Be sure to understand the meanings of the following terms and comply with the content (instructions) of the instruction manual.

■ Explanation of the warning terms

Warning Term	Meaning
Danger	Indicates an imminently hazardous situation. Failure to observe this will result in death or serious injury.
Warning	Indicates a potentially hazardous situation. Failure to observe this will result in death or serious injury.
Caution	Indicates a potentially hazardous situation. Failure to observe this will result in minor or moderate injury or property damage.
Note	Indicates information that is in particular to be noted or emphasized.















■ Explanation of the graphic symbols















Don'ts	Do not touch	Do not disassemble	Do not touch with wet hand	Do not expose to water
These graphic symbols indicate prohibited actions (that must NOT be done).				
	This graphic symbol indicates mandatory actions (that must be done).			
Do's				
Caution	Electric shock hazard	Rotation hazard	Hot surface	
These graphic symbols indicate existing hazards to beware of.				

1.2 Safety precautions

Danger	
	Once the main power is turned on, do not touch any live parts. A high voltage applied to live parts may cause a serious electric shock, thus leading to death.
	Do not use the product in any explosive atmosphere. Otherwise, it may lead to an injury or fire.





















Warning	
	Properly move the unit according to hoisting instructions. Otherwise, the unit may fall, thus leading to an injury or damage.
	Do not carry out any work with/on the pump that is being hoisted. Otherwise, the unit may fall, thus leading to an injury or damage.
	Only those who are authorized by the site manager are allowed to operate the pump. Operation by unskilled personnel may lead to an unforeseen accident.
	Installation, maintenance, and inspection must only be carried out by personnel who have been trained to handle the pump. Operation by unskilled personnel may lead to an unforeseen accident.
	Only qualified personnel, such as licensed electrical engineers, are allowed to carry out electric work. Otherwise, it may lead to an electric shock, fire, failure, or other problems.
	Use high-quality wiring equipment and devices, and carry out wiring work safely and securely according to the technical standards for electrical facilities, as well as the indoor wiring regulations. Otherwise, it may lead to an electric shock, fire, or other problems.
	Do not connect the ground wire to a gas pipe or water pipe. Such a connection is illegal and leads to an electric shock, explosion, or fire.
	Securely install the ground wire and ensure to carry out grounding work. Otherwise, it may lead to an electric leak or electric shock.
	Correctly and securely connect the wires according to the wiring diagram within the terminal box and the instruction manual. Incorrect wiring may cause a fire, electric shock, failure, or other problems.
	Do not run the unit if abnormal condition is observed in any operation, movement, parts, etc. Otherwise, it may lead to an injury, failure, or various accidents.

 Warning	
 Be sure to keep the terminal box cover attached during the operation of the pump. Otherwise, it may lead to an electric shock.	 Be sure to install the coupling cover during the operation of the pump. Otherwise, it may lead to an injury or damage.
 After detaching the companion flange from the pump, screw a pipe into it. Otherwise, it may lead to damage or liquid leakage.	 Do not forcibly bend, pull, or pinch the power cable or any lead wires of the product. Otherwise, it may lead to an electric shock or fire.
 Check the wiring sections and wires for any looseness. A loose connection may cause a fire or electric shock.	 Before starting the maintenance or inspection work, be sure to stop the pump and turn off the main power of the panel board. Otherwise, it may lead to an electric shock, injury, damage, or liquid leakage.
 Before starting the unit or carrying out maintenance/inspection work, ensure that all the relevant workers are informed of the operation and that there are no workers in the dangerous zone. Otherwise, it may lead to an unforeseen accident.	 Before rotating the main shaft by hand to check its smooth rotation, be sure to turn off the main power. Otherwise, it may lead to an injury or damage.
 After turning on the power, do not touch any parts of the pump other than those required for operation. Otherwise, it may lead to an electric shock or injury.	 Do not perform zero-discharge operation for more than 5 minutes in a row. Otherwise, the temperature and pressure may increase inside the pump, thus damaging the pump or causing steam to blow off.
 Do not put your fingers or foreign objects into any openings or rotating part of the motor during operation. Otherwise, it may lead to an injury or damage.	 For overhaul, replacement of parts, or repairs, ask the vendor or the service center specified by Teral. If unskilled personnel carry out work that requires special knowledge, it may lead to an accident or failure.
 In the event of a power failure, be sure to turn off the power switch. Otherwise, the pump may suddenly start up on restoration of the power, thus leading to an injury.	

 Caution	
 Do not use the unit outside the range of the product specifications. Otherwise, it may lead to an electric shock, fire, leakage, failure, or other problems.	 Do not use the unit at an incorrect power voltage. An incorrect voltage may damage the motor.
 Do not use a single pump unit as the only means of directly operating key facilities or sustaining life. In the event of a failure, the liquid supply may stop. Ensure to make a backup unit available for operation.	 Before unpacking the delivered container, check that the container is placed in the correct orientation (not upside down). Carefully unpack the container, while paying special attention to nails. Otherwise, it may lead to an injury or damage.
 Ensure that the floor at the unit's installation place is waterproofed and fitted with drainage. Otherwise, it may lead to serious damage in the event of leakage.	 Do not install two or more different cables or control wires in one pipe or duct. Otherwise, it may lead to malfunction of the product or other equipment.
 Do not step on the pump or motor. Otherwise, it may lead to an injury, damage, or other problems.	 Do not expose the motor to liquid. Otherwise, it may lead to an electric shock, electric leak, failure, or other problems.
 Operate the controls carefully. Otherwise, it may lead to an injury or damage.	 During test operation, never run the pump dry (i.e. never run the pump when the liquid level is below the Minimum liquid level). Otherwise, it may lead to damage or a fire.
 Before operation, thoroughly clean (flush) the inside of the piping to remove foreign matter. Otherwise, the piping system may be contaminated with foreign matter, thus leading to an accident or a pump failure.	 During normal operation, do not run the pump dry for more than 30 seconds. Otherwise, it may lead to damage or a fire.
 Do not put a cloth or other covering on the motor. Otherwise, it may lead to overheating or ignition.	 Do not touch the motor body while the pump is running or immediately after the pump has stopped. Otherwise, you may get burns from the hot surface.



Caution

 <p>In the event of an alarm or abnormal condition that cannot be resolved, immediately stop the operation, turn off the power, and then contact Teral or its service provider. Otherwise, it may lead to an accident.</p>	 <p>Do not run the pump with tools or other objects placed on the unit. Otherwise, it may lead to an injury or damage.</p>
 <p>Check that the delivered items are exactly what you ordered. The use of a wrong product may cause an injury or failure.</p>	 <p>Do not hold the strainer located on the tip of the pump. Otherwise, the strainer may come off, thus leading to an injury or damage.</p>
 <p>Check the rotation direction of the pump before connecting it to the machine. Otherwise, it may lead to an injury or damage.</p>	 <p>Do not place any combustibles around the product. Otherwise, it may lead to a fire.</p>
 <p>Do not place any obstacles around the product that may hinder ventilation. Otherwise, it may lead to a fire.</p>	 <p>Do not touch the impeller, tie bolt, strainer, screw, or other parts of the pump with bare hands. Otherwise, it may lead to an injury or damage.</p>
 <p>Do not run a pump power supply at 60Hz. Otherwise, it may lead to motor burnout or a fire.</p>	  <p>Do not touch any terminals or wires when measuring the insulation resistance. Otherwise, it may lead to an electric shock.</p>
 <p>Ensure to install an overcurrent protective device. The user is required by the technical standards for electrical facilities to install one. Otherwise, it may damage the product, thus leading to a fire or failure. It is also recommended to install protective devices such as a ground fault interrupter.</p>	 <p>Once you turn off the power, wait until the pump stops completely. Do not restart the pump until it does. Otherwise, the main shaft may be subjected to an excessive load, which makes the service life of the pump shorter.</p>
 <p>Do not run the pump with its strainer removed. Otherwise, it may lead to an injury or damage.</p>	 <p>If you use a solvent for cleaning the product, pay attention to handling of the solvent as well as the environment of use. Otherwise, it may lead to poisoning.</p>
 <p>Do not touch the screw after removing the strainer. Otherwise, it may lead to an injury.</p>	 <p>Dispose of the product as industrial waste.</p>
 <p>Do not use thinner or benzene for cleaning the product. Otherwise, the product may be discolored or its coating may be peeled off.</p>	 <p>When you lift the product by hand, pay attention to its weight. Do not allow a single person to lift a product heavier than 15 kg. Otherwise, it may put strain on the body, thus leading to an injury.</p>
 <p>When you hoist the product, pay attention to its center of gravity. Otherwise, the product may topple over or fall, thus leading to an injury.</p>	 <p>Be sure to conduct inspection according to the Maintenance checklist. Otherwise, you cannot prevent potential failures, thus leading to a higher risk of accidents.</p>

1.3 Location of warning labels and caution labels

The figure shows the locations of warning labels and caution labels. If these labels become dirty and illegible or if they are peeled off, replace them with a new one.

 **Warning**  **Caution** 

Observe all the instructions in the warnings and cautions affixed to the machine as well as those described in this instruction manual.

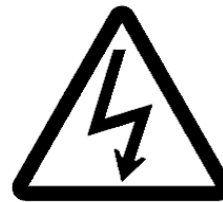
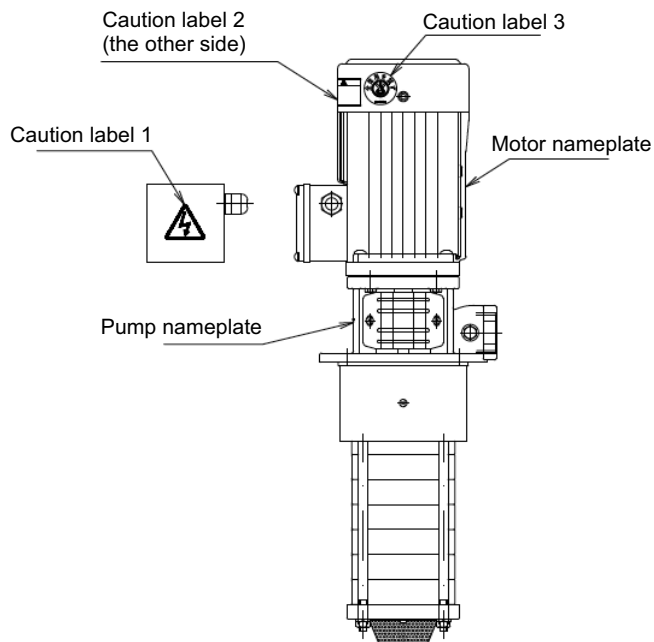

Caution label 1

 **Caution**

Do not allow dust or dirt to adhere to or accumulate on the fan cover, frame, or fan of the motor. Otherwise, blocked airflow may lead to insufficient cooling and hot surfaces, ultimately damaging the bearing and body of the motor.



Caution label 2



Caution label 3
(3.0 kW or more)

2. Configuration and overview of the pump

This chapter describes the standard specifications of the pump. For details, refer to the delivery specifications such as the dimensional outline drawing and the internal structure drawing. If you have purchased a customized product, some information in this chapter may not be applicable to your unit. See the dimensional outline drawing, the internal structure drawing, and other documents to check the product specifications in such a case.

 **Caution** 

Do not use this product under any conditions other than those provided in the specifications. Otherwise, it may lead to an electric shock, fire, leakage, or failure.

2.1 Part names and functions

- ① Motor
- ② Discharge port
- ③ Suction port (with strainer)
- ④ Air vent valve

If the discharge piping is not open to the atmosphere, this valve allows you to discharge air from the pump to prevent dry running.

- ⑤ Coupling cover

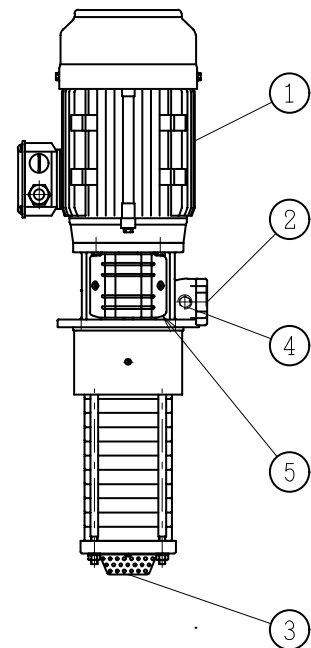

 **Warning**  **Caution**  

Be sure to keep the coupling cover and strainer attached during the operation of the pump. Otherwise, it may lead to an injury.

2.2 Naming rule of the model codes

50 LVS 10-20/12-6 7.5 -KS

① ② ③ ④ ⑤ ⑥ ⑦ ⑧ ⑨

- | | |
|---|---|
| <ul style="list-style-type: none"> ① Discharge bore [mm] (32, 50) ② Model ③ Nominal flow rate [m³/h]
(1, 3, 5, 10, 15, 20) ④ Number of casing stages (3 to 22) | <ul style="list-style-type: none"> ⑤ Number of impellers (1 to 22) ⑥ Frequency [Hz] (6: 60Hz) ⑦ Output [kW] (0.75 to 7.5) ⑧ Identification mark : -MR* ⑨ Equipped with a motor compliant with Korea energy class indication system (grade IE3) |
|---|---|

* Model LVS-MR-e is different from LVS-e only in the connection of lead wire.

The other specifications, outer dimensions, and structure are all the same as LVS-e.

2.3 Standard specifications *

Applicable liquid	Quality	Grinding fluid, cutting fluid, etc. after secondary treatment ^{Note 1}
	Temperature	0 to 90°C (No frozen liquid is allowed.)
Installation location		Indoors; height above sea level: 1,000 m or less; ambient temperature: 0 to 40°C; humidity:85%RH or less (no condensing); place not exposed to direct sunlight; place without any corrosive gas, explosive gas, or vapor in the atmosphere
Material	Suction/Discharge casing	FC200
	Interstage casing	SUS304
	Impeller	SUS304
	Main shaft	SUS420J2
Shaft sealing structure		Sealless structure (without mechanical seal)
Motor	Type	Totally-enclosed fan-cooled outdoor type ^{Note 2}
	IP protection	IP55
	Power ^{Note 3}	3-phase 60Hz 0.75kW~7.5kW:200-230V
	Insulation class	Class F
	Number of poles	2P
	Standard	IEC60034-1
Noise [dB(A)]		79
Coating color		Munsell N1

Note 1 Under the conditions that contain hard sludge—such as abrasive powders, grinding powders, and diamond abrasive grains—in the pumping fluid, the service life of the product may become shorter. In such a case, install a filter (e.g. magnet filter or paper filter). Note that the product cannot be used for water or special liquids such as printing liquids or acidic liquids. For other special liquids (e.g. pure water, alkaline/acidic liquids, and ceramic liquids), contact Teral.

Note 2 This pump can't be used at outdoor.

Note 3 Limit the fluctuations of the power voltage within $\pm 10\%$ of the rated voltage, and also limit the fluctuations of the frequency between -5% and $+3\%$ of the rated value. Avoid continuous operation if the voltage is not within $\pm 5\%$ of the rated value or if the frequency is not within $\pm 2\%$ of the rated value.

* This product is labeled with a self-declaration CE mark and complies with the Essential Safety Requirements (ESRs) of the “EU (EC) Directive.” The following are the general descriptions.

Manufacturer	Teral Inc. 230 Moriwake, Miyuki-cho, Fukuyama-city, Hiroshima 720-0003 Japan
Product	LVS-e model coolant pump
Standards	Machinery Directive 2006/42/EC
	EN 809/A1:2009, EN ISO 12100:2010, EN 60204-1/A1:2009
Manufacturer (Japan)	Teral Inc., Hiroshima
Administrator (EU nations)	Shiran Tower 5F Luzna 716/2 160 00 Vokovice, Praha 6 CZECH REPUBLIC Person in charge: Tomohisa Yamamoto
Place of declaration	Hiroshima, Japan Manager: Taiji Monden

2.4 Information indicated on the nameplates

The specifications of the pump are indicated on the nameplate. Upon receiving the pump, check the nameplate to verify that the delivered product is exactly what you ordered. Be sure to confirm the model, motor output, frequency, and voltage. If there is anything different from what you ordered, contact the vendor from which you purchased the product.

Do not remove the nameplate or place any obstacles in front of it. Always keep the nameplate clearly visible.



Do not run a pump power supply at 60Hz. Otherwise, it may lead to overload and motor burnout.
Running a 60Hz pump at 50Hz reduces its performance.

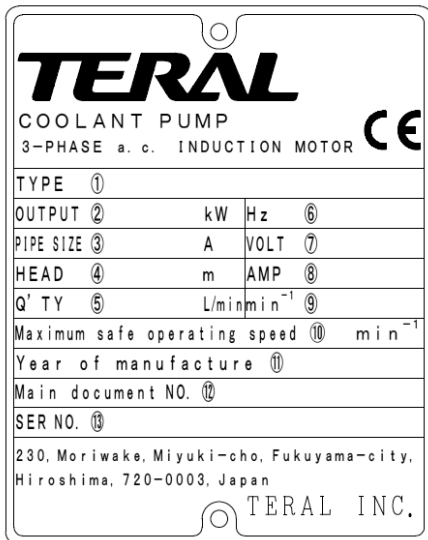

Pump nameplate

No.	Item
1	Model
2	Motor output (kW)
3	Discharge bore (A)
4	Total head (m)
5	Discharge rate (L/min)
6	Frequency (Hz)
7	Voltage (V)
8	Current (A)
9	Rotation speed (min ⁻¹)
10	Max. allowable rotation speed (min ⁻¹)
11	Year of manufacture
12	Instruction manual No.
13	Serial number

Specification table

- 60Hz (Synchronous rotation speed: 3600 min⁻¹)

Discharge bore: 32mm, nominal flow rate: 1m³/h

型式	32LVS1- □/8-6.75-KS	32LVS1- □/10-61.1-KS	32LVS1- □/13-61.1-KS	32LVS1- □/15-61.5-KS	32LVS1- □/17-61.5-KS	32LVS1- □/21-62.2-KS	32LVS1- □/23-62.2-KS	32LVS1- □/25-62.2-KS	32LVS1- □/27-63.0-KS
口径 (mm)	32								
吐出量 (ℓ/min)	10~50								
全行程 (m)	67 ~ 35	84 ~ 44	109 ~ 57	126 ~ 66	142.5 ~ 75	176.5 ~ 92.5	193 ~ 101.5	210 ~ 110.5	227 ~ 119
定格出力 (kW)	0.75	1.1		1.5		2.2		3.0	
電動機	200/230								
定格電圧 (V)	200/230								
定格電流 (A)	3.2/3.1	4.4/4.1		5.9/5.4		8.4/7.6		11.5/10.8	
始動電流 (A)	25.0/28.5	32.5/37.0		41.0/47.6		78.0/82.6		115/135	

Note 1 If you need to pump oil-based coolant or special liquids (e.g. pure water, alkaline/acidic liquids), consult Teral.
 Note 2 The rated electric current in the above table (current value indicated on the pump nameplate) is the recommended preset current value of the protective device.

Discharge bore: 32mm, nominal flow rate: 3m³/h

型式	32LVS3- □/5-6.75-KS	32LVS3- □/6-61.1-KS	32LVS3- □/7-61.1-KS	32LVS3- □/8-61.1-KS	32LVS3- □/10-61.5-KS	32LVS3- □/11-61.5-KS	32LVS3- □/12-62.2-KS	32LVS3- □/15-62.2-KS	32LVS3- □/17-62.2-KS	32LVS3- □/19-63.0-KS	32LVS3- □/23-63.0-KS	32LVS3- □/26-64.0-KS
口径 (mm)	32											
吐出量 (ℓ/min)	20~90											
全行程 (m)	43 ~ 17.5	51.5 ~ 21	60 ~ 24.5	69 ~ 28	86 ~ 35.5	94.5 ~ 39	103.5 ~ 42.5	129.5 ~ 53	146.5 ~ 60	164 ~ 67	198.5 ~ 81.5	224.5 ~ 92
定格出力 (kW)	0.75	1.1		1.5		2.2		3.0		4.0		
電動機	200/230											
定格電圧 (V)	200/230											
定格電流 (A)	3.2/3.1	4.4/4.1		5.9/5.4		8.4/7.6		11.5/10.8		14.3/12.8		18.0/16.5
始動電流 (A)	25.0/28.5	32.5/37.0		41.0/47.6		78.0/82.6		115/135		178/206		254/295

Note 1 If you need to pump oil-based coolant or special liquids (e.g. pure water, alkaline/acidic liquids), consult Teral.
 Note 2 The rated electric current in the above table (current value indicated on the pump nameplate) is the recommended preset current value of the protective device.

Discharge bore: 32mm, nominal flow rate: 5m³/h

型式	32LVS5- □/3-61.1-KS	32LVS5- □/4-61.1-KS	32LVS5- □/5-61.5-KS	32LVS5- □/6-62.2-KS	32LVS5- □/7-62.2-KS	32LVS5- □/8-62.2-KS	32LVS5- □/10-63.0-KS	32LVS5- □/12-63.0-KS	32LVS5- □/14-64.0-KS	32LVS5- □/16-64.0-KS	32LVS5- □/20-65.5-KS	32LVS5- □/22-65.5-KS	32LVS5- □/24-67.5-KS
口径 (mm)	32												
吐出量 (ℓ/min)	40~180												
全行程 (m)	27.5 ~ 11	36.5 ~ 15	46 ~ 18.5	55 ~ 22.5	64 ~ 26.5	73.5 ~ 30	92 ~ 37.5	110.5 ~ 45	128.5 ~ 53	147 ~ 60.5	184 ~ 75.5	202.5 ~ 83	221 ~ 90.5
定格出力 (kW)	1.1	1.5	2.2		3.0		4.0		5.5		7.5		
電動機	200/230												
定格電圧 (V)	200/230												
定格電流 (A)	4.4/4.1	5.9/5.4		8.4/7.6		11.5/10.8		14.3/12.8		19.8/17.8		26.5/23.7	
始動電流 (A)	32.5/37.0	41.0/47.6		78.0/82.6		115/135		178/206		254/295			

Note 1 If you need to pump oil-based coolant or special liquids (e.g. pure water, alkaline/acidic liquids), consult Teral.
 Note 2 The rated electric current in the above table (current value indicated on the pump nameplate) is the recommended preset current value of the protective device.

Discharge bore: 50mm, nominal flow rate: 10m³/h

型式	50LVS10- □/1-6.75-KS	50LVS10- □/2-61.5-KS	50LVS10- □/3-62.2-KS	50LVS10- □/4-63.0-KS	50LVS10- □/5-63.0-KS	50LVS10- □/6-64.0-KS	50LVS10- □/8-65.5-KS	50LVS10- □/9-65.5-KS	50LVS10- □/10-67.5-KS	50LVS10- □/12-67.5-KS	
口径 (mm)	50										
吐出量 (ℓ/min)	100~280										
全行程 (m)	14 ~ 5	28.5 ~ 13	43 ~ 21	57.5 ~ 28.5	72 ~ 36.5	86.5 ~ 44	115.5 ~ 58.5	130 ~ 66	144.5 ~ 73	173.5 ~ 88	
定格出力 (kW)	0.75	1.5	2.2	3.0		4.0	5.5		7.5		
電動機	200/230										
定格電圧 (V)	200/230										
定格電流 (A)	3.2/3.1	5.9/5.4	8.4/7.6	11.5/10.8		14.3/12.8	19.8/17.8		26.5/23.7		
始動電流 (A)	25.0/28.5	41.0/47.6	78.0/82.6	115/135		178/206			254/295		

Note 1 If you need to pump oil-based coolant or special liquids (e.g. pure water, alkaline/acidic liquids), consult Teral.
 Note 2 The rated electric current in the above table (current value indicated on the pump nameplate) is the recommended preset current value of the protective device.

Discharge bore: 50mm, nominal flow rate: 15m³/h

型式	50LVS15- □/1-61.5-KS	50LVS15- □/2-63.0-KS	50LVS15- □/3-64.0-KS	50LVS15- □/4-65.5-KS	50LVS15- □/5-67.5-KS
口径 (mm)	50				
吐出量 (ℓ/min)	160~450				
全行程 (m)	18 ~ 9.5	37 ~ 22	55.5 ~ 24.5	74 ~ 46	92.5 ~ 57.5
定格出力 (kW)	1.5	3.0	4.0	5.5	7.5
電動機	200/230				
定格電圧 (V)	200/230				
定格電流 (A)	5.9/5.4	11.5/10.8	14.3/12.8	19.8/17.8	26.5/24.4
始動電流 (A)	41.0/47.6	115/135	178/206	254/295	

Note 1 If you need to pump oil-based coolant or special liquids (e.g. pure water, alkaline/acidic liquids), consult Teral.
 Note 2 The rated electric current in the above table (current value indicated on the pump nameplate) is the recommended preset current value of the protective device.

Discharge bore: 50mm, nominal flow rate: 20m³/h

型式	50LVS20- □/1-62.2-KS	50LVS20- □/2-64.0-KS	50LVS20- □/3-65.5-KS	50LVS20- □/4-67.5-KS
口径 (mm)	50			
吐出量 (ℓ/min)	220~600			
全行程 (m)	19 ~ 7	39 ~ 18	58.5 ~ 29.5	78 ~ 39.5
定格出力 (kW)	2.2	4.0	5.5	7.5
電動機	200/230			
定格電圧 (V)	200/230			
定格電流 (A)	8.4/7.6	14.3/12.8	19.8/17.8	26.5/24.4
始動電流 (A)	78.0/82.6	132/151	178/206	253.7/281.9

Note 1 If you need to pump oil-based coolant or special liquids (e.g. pure water, alkaline/acidic liquids), consult Teral.
 Note 2 The rated electric current in the above table (current value indicated on the pump nameplate) is the recommended preset current value of the protective device.

2.5 Dimensional outline drawing and dimensions table

Discharge bore: 32 mm

(1) Dimensional outline drawing

Figure 1

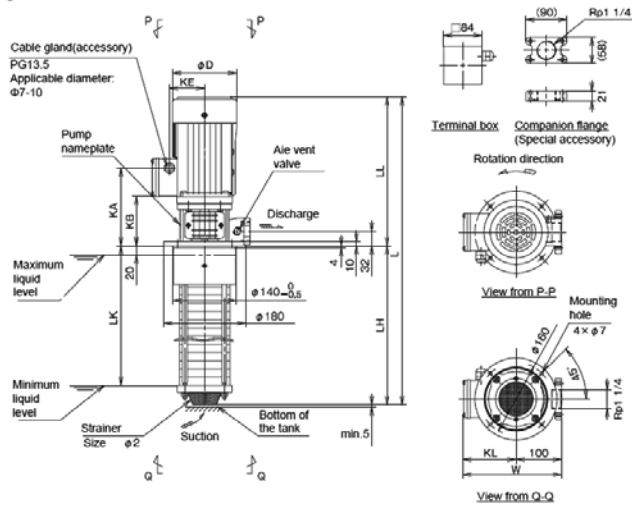
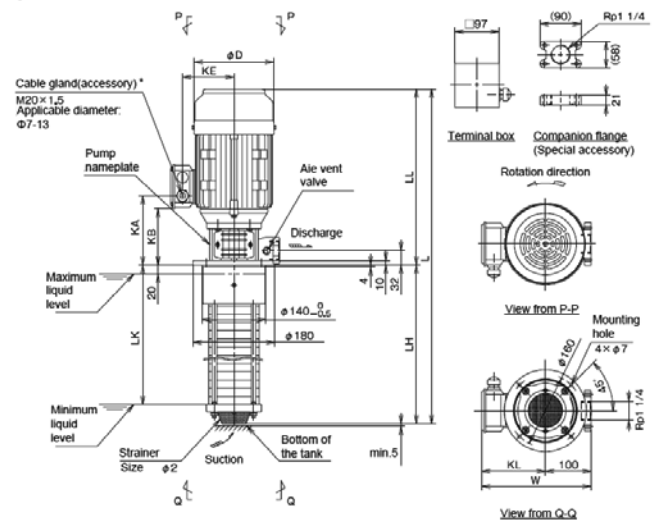
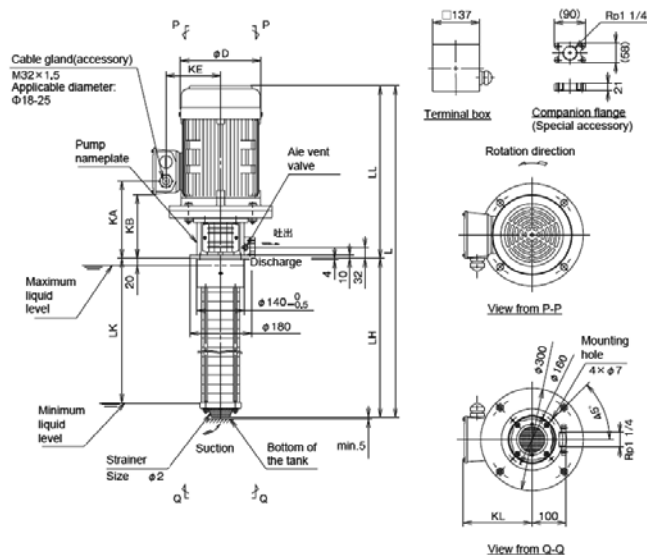

Figure 2



*In case of LV5-MR-e, the dimensions are changed as follows.
 • Conversion adapter PG16, Applicable diameter phi 7~13

Figure 3



Typical models are shown in these figures. The shapes may be slightly different depending on the model and specifications. Because some of the specifications may be changed due to design changes or for other reasons, refer to the delivery specifications when planning your pumping work.

(2) Dimensions table

<Unit:mm>

OUTPUT kW	Fig.	D	KA	KB	KE	KL	LL	W
0.75	1	141	171	109	77	117	327	217
1.1	2	175	147	118	113	140	381	240
1.5/2.2		175	168	139	113	140	402	240
3.0		196	179	149	125	152	435	252
4.0		219	183	154	134	161	442	—
5.5	3	234	226	186	160	202	505	—
7.5		234	227	186	160	202	545	—

■ Discharge bore: 32mm, nominal flow rate: 1m³/h

•60Hz

<Unit: mm>

Model	Fig	L	LH	LK	Approx weight (kg)	
32LVS1-8/8-6.75-KS	1	586	259	217	20	
32LVS1-10/8-6.75-KS		622	295	253	20	
32LVS1-13/8-6.75-KS		676	349	307	21	
32LVS1-15/8-6.75-KS		712	385	343	22	
32LVS1-17/8-6.75-KS		748	421	379	22	
32LVS1-21/8-6.75-KS		820	493	451	23	
32LVS1-25/8-6.75-KS		892	565	523	24	
32LVS1-10/10-61.1-KS	2	676	295	253	25	
32LVS1-13/10-61.1-KS		730	349	307	25	
32LVS1-15/10-61.1-KS		766	385	343	26	
32LVS1-17/10-61.1-KS		802	421	379	26	
32LVS1-21/10-61.1-KS		874	493	451	27	
32LVS1-25/10-61.1-KS		946	565	523	28	
32LVS1-13/13-61.1-KS		730	349	307	25	
32LVS1-15/13-61.1-KS		766	385	343	26	
32LVS1-17/13-61.1-KS		802	421	379	26	
32LVS1-21/13-61.1-KS		874	493	451	27	
32LVS1-25/13-61.1-KS		946	565	523	28	
32LVS1-15/15-61.5-KS		2	787	385	343	30
32LVS1-17/15-61.5-KS			823	421	379	31
32LVS1-21/15-61.5-KS			895	493	451	31
32LVS1-25/15-61.5-KS	967		565	523	32	
32LVS1-30/15-61.5-KS	1057		655	613	34	
32LVS1-17/17-61.5-KS	823		421	379	31	
32LVS1-21/17-61.5-KS	895		493	451	32	
32LVS1-25/17-61.5-KS	967		565	523	33	
32LVS1-30/17-61.5-KS	1057		655	613	34	
32LVS1-33/17-61.5-KS	1111		709	667	34	
32LVS1-21/21-62.2-KS	895		493	451	35	
32LVS1-25/21-62.2-KS	967		565	523	36	
32LVS1-30/21-62.2-KS	1057		655	613	37	
32LVS1-33/21-62.2-KS	1111		709	667	38	
32LVS1-36/21-62.2-KS	1165		763	721	39	
32LVS1-23/23-62.2-KS	931		529	487	36	
32LVS1-27/23-62.2-KS	1003		601	559	37	
32LVS1-30/23-62.2-KS	1057		655	613	37	
32LVS1-33/23-62.2-KS	1111		709	667	38	
32LVS1-36/23-62.2-KS	1165		763	721	39	
32LVS1-25/25-62.2-KS	967		565	523	36	
32LVS1-27/25-62.2-KS	1003		601	559	37	
32LVS1-30/25-62.2-KS	1057		655	613	38	
32LVS1-33/25-62.2-KS	1111		709	667	38	
32LVS1-36/25-62.2-KS	1165		763	721	39	
32LVS1-27/27-63.0-KS	2		1036	601	559	45
32LVS1-30/27-63.0-KS			1090	655	613	46
32LVS1-33/27-63.0-KS			1144	709	667	46
32LVS1-36/27-63.0-KS		1198	763	721	47	

■ Discharge bore: 32mm, nominal flow rate: 3m³/h

• 60Hz

<Unit: mm>

Model	Fig	L	LH	LK	Approx weight (kg)	
32LVS3-5/5-6.75-KS	1	532	205	163	19	
32LVS3-7/5-6.75-KS		568	241	199	19	
32LVS3-10/5-6.75-KS		622	295	253	20	
32LVS3-12/5-6.75-KS		658	331	289	21	
32LVS3-15/5-6.75-KS		712	385	343	21	
32LVS3-19/5-6.75-KS		784	457	415	22	
32LVS3-23/5-6.75-KS		856	529	487	23	
32LVS3-6/6-61.1-KS	2	604	223	181	23	
32LVS3-10/6-61.1-KS		676	295	253	24	
32LVS3-12/6-61.1-KS		712	331	289	25	
32LVS3-15/6-61.1-KS		766	385	343	26	
32LVS3-19/6-61.1-KS		838	457	415	26	
32LVS3-23/6-61.1-KS		910	529	487	27	
32LVS3-7/7-61.1-KS		622	241	199	24	
32LVS3-10/7-61.1-KS		676	295	253	24	
32LVS3-12/7-61.1-KS		712	331	289	25	
32LVS3-15/7-61.1-KS		766	385	343	26	
32LVS3-19/7-61.1-KS		838	457	415	26	
32LVS3-23/7-61.1-KS		910	529	487	27	
32LVS3-8/8-61.1-KS		640	259	217	24	
32LVS3-10/8-61.1-KS		676	295	253	24	
32LVS3-12/8-61.1-KS		712	331	289	25	
32LVS3-15/8-61.1-KS		766	385	343	26	
32LVS3-19/8-61.1-KS		838	457	415	27	
32LVS3-23/8-61.1-KS		910	529	487	27	
32LVS3-10/10-61.5-KS		2	697	295	253	29
32LVS3-12/10-61.5-KS			733	331	289	29
32LVS3-15/10-61.5-KS			787	385	343	30
32LVS3-19/10-61.5-KS	859		457	415	31	
32LVS3-23/10-61.5-KS	931		529	487	32	
32LVS3-11/11-61.5-KS	715		313	271	29	
32LVS3-15/11-61.5-KS	787		385	343	30	
32LVS3-19/11-61.5-KS	859		457	415	31	
32LVS3-23/11-61.5-KS	931		529	487	32	
32LVS3-12/12-62.2-KS	733		331	289	33	
32LVS3-15/12-62.2-KS	787		385	343	33	
32LVS3-19/12-62.2-KS	859		457	415	34	
32LVS3-23/12-62.2-KS	931		529	487	35	
32LVS3-15/15-62.2-KS	787		385	343	34	
32LVS3-19/15-62.2-KS	859		457	415	34	
32LVS3-23/15-62.2-KS	931		529	487	35	
32LVS3-26/15-62.2-KS	985		583	541	36	
32LVS3-17/17-62.2-KS	823		421	379	34	
32LVS3-23/17-62.2-KS	931		529	487	35	
32LVS3-26/17-62.2-KS	985		583	541	36	
32LVS3-30/17-62.2-KS	1057		655	613	37	
32LVS3-19/19-63.0-KS	2	892	457	415	43	
32LVS3-23/19-63.0-KS		964	529	487	43	
32LVS3-26/19-63.0-KS		1018	583	541	44	
32LVS3-30/19-63.0-KS		1090	655	613	45	
32LVS3-36/19-63.0-KS		1198	763	721	46	
32LVS3-23/23-63.0-KS		964	529	487	44	
32LVS3-26/23-63.0-KS		1018	583	541	44	
32LVS3-30/23-63.0-KS		1090	655	613	45	
32LVS3-36/23-63.0-KS		1198	763	721	47	
32LVS3-26/26-64.0-KS		2	1025	583	541	50
32LVS3-30/26-64.0-KS	1097		655	613	51	
32LVS3-36/26-64.0-KS	1205		763	721	52	

■ Discharge bore: 32mm, nominal flow rate: 5m³/h

• 60Hz

<Unit: mm>

Model	Fig	L	LH	LK	Approx weight (kg)	
32LVS5-3/3-61.1-KS	2	583	196	154	23	
32LVS5-5/3-61.1-KS		637	250	208	24	
32LVS5-7/3-61.1-KS		691	304	262	24	
32LVS5-10/3-61.1-KS		772	385	343	25	
32LVS5-14/3-61.1-KS		880	493	451	26	
32LVS5-16/3-61.1-KS		934	547	505	27	
32LVS5-20/3-61.1-KS		1042	655	613	28	
32LVS5-4/4-61.1-KS		610	223	181	23	
32LVS5-6/4-61.1-KS		664	277	235	24	
32LVS5-8/4-61.1-KS		718	331	289	24	
32LVS5-10/4-61.1-KS		772	385	343	25	
32LVS5-14/4-61.1-KS		880	493	451	27	
32LVS5-16/4-61.1-KS		934	547	505	28	
32LVS5-20/4-61.1-KS		1042	655	613	29	
32LVS5-5/5-61.5-KS	2	652	250	208	28	
32LVS5-7/5-61.5-KS		706	304	262	28	
32LVS5-10/5-61.5-KS		787	385	343	29	
32LVS5-14/5-61.5-KS		895	493	451	31	
32LVS5-16/5-61.5-KS		949	547	505	31	
32LVS5-20/5-61.5-KS		1057	655	613	33	
32LVS5-6/6-62.2-KS		679	277	235	32	
32LVS5-8/6-62.2-KS		733	331	289	32	
32LVS5-10/6-62.2-KS		787	385	343	33	
32LVS5-14/6-62.2-KS		895	493	451	34	
32LVS5-16/6-62.2-KS		949	547	505	35	
32LVS5-20/6-62.2-KS		1057	655	613	36	
32LVS5-7/7-62.2-KS		706	304	262	32	
32LVS5-10/7-62.2-KS		787	385	343	33	
32LVS5-14/7-62.2-KS		895	493	451	34	
32LVS5-16/7-62.2-KS		949	547	505	35	
32LVS5-20/7-62.2-KS		1057	655	613	36	
32LVS5-8/8-62.2-KS		733	331	289	32	
32LVS5-10/8-62.2-KS		787	385	343	33	
32LVS5-14/8-62.2-KS		895	493	451	34	
32LVS5-16/8-62.2-KS		949	547	505	35	
32LVS5-20/8-62.2-KS		1057	655	613	36	
32LVS5-10/10-63.0-KS		4	820	385	343	41
32LVS5-14/10-63.0-KS			928	493	451	42
32LVS5-16/10-63.0-KS			982	547	505	43
32LVS5-20/10-63.0-KS			1090	655	613	44
32LVS5-12/12-63.0-KS			874	439	397	42
32LVS5-14/12-63.0-KS			928	493	451	42
32LVS5-16/12-63.0-KS	982		547	505	43	
32LVS5-20/12-63.0-KS	1090		655	613	44	
32LVS5-24/12-63.0-KS	1198		763	721	45	
32LVS5-14/14-64.0-KS	2		935	493	451	48
32LVS5-16/14-64.0-KS		989	547	505	49	
32LVS5-20/14-64.0-KS		1097	655	613	50	
32LVS5-24/14-64.0-KS		1205	763	721	51	
32LVS5-29/14-64.0-KS		1340	898	856	53	
32LVS5-16/16-64.0-KS		989	547	505	49	
32LVS5-20/16-64.0-KS		1097	655	613	50	
32LVS5-24/16-64.0-KS		1205	763	721	51	
32LVS5-29/16-64.0-KS		1340	898	856	53	
32LVS5-32/16-64.0-KS		1421	979	937	54	
32LVS5-20/20-65.5-KS	3	1160	655	613	78	
32LVS5-24/20-65.5-KS		1268	763	721	79	
32LVS5-29/20-65.5-KS		1403	898	856	80	
32LVS5-32/20-65.5-KS		1484	979	937	81	
32LVS5-22/22-65.5-KS		1214	709	667	78	
32LVS5-24/22-65.5-KS		1268	763	721	79	
32LVS5-29/22-65.5-KS		1403	898	856	80	
32LVS5-32/22-65.5-KS		1484	979	937	81	
32LVS5-24/24-67.5-KS	3	1308	763	721	86	
32LVS5-29/24-67.5-KS		1443	898	856	87	
32LVS5-32/24-67.5-KS		1524	979	937	88	

Discharge bore: 50 mm

(1) Dimensional outline drawing

Figure 1

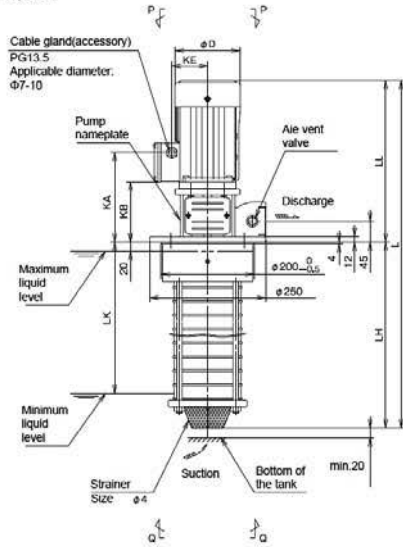

Figure 2

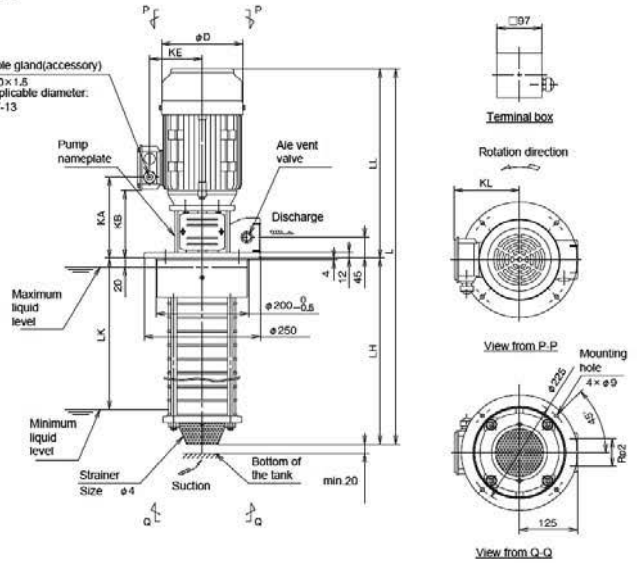
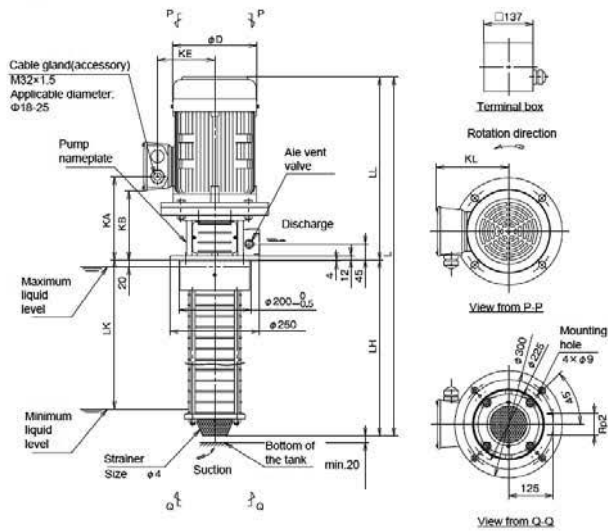

Figure 3



Typical models are shown in these figures. The shapes may be slightly different depending on the model and specifications. Because some of the specifications may be changed due to design changes or for other reasons, refer to the delivery specifications when planning your pumping work.

(2) Dimensions table

<Unit:mm>

出力 kW	図	D	KA	KB	KE	KL	LL
0.75	1	141	193	130	77	117	349
1.1	2	175	169	140	113	140	403
1.5/2.2		175	175	146	113	140	409
3.0		196	186	156	125	152	442
4.0	3	219	190	161	134	161	449
5.5		234	233	193	160	202	512
7.5		234	234	193	160	202	552

■ Discharge bore: 50mm, nominal flow rate: 10m³/h

•60Hz

<Unit: mm>

Model	Fig	L	LH	LK	Approx weight (kg)	
50LVS10-5/1-6.75-KS	1	631	282	207	28	
50LVS10-6/1-6.75-KS		661	312	237	28	
50LVS10-8/1-6.75-KS		721	372	297	30	
50LVS10-10/1-6.75-KS		781	432	357	31	
50LVS10-12/1-6.75-KS		841	492	417	32	
50LVS10-5/2-61.5-KS	2	691	282	207	36	
50LVS10-6/2-61.5-KS		721	312	237	36	
50LVS10-8/2-61.5-KS		781	372	297	38	
50LVS10-10/2-61.5-KS		841	432	357	39	
50LVS10-12/2-61.5-KS		901	492	417	40	
50LVS10-14/2-61.5-KS		961	552	477	42	
50LVS10-16/2-61.5-KS		1021	612	537	43	
50LVS10-18/2-61.5-KS		1081	672	597	44	
50LVS10-20/2-61.5-KS		1141	732	657	46	
50LVS10-22/2-61.5-KS		1201	792	717	47	
50LVS10-5/3-62.2-KS		2	691	282	207	39
50LVS10-6/3-62.2-KS			721	312	237	40
50LVS10-8/3-62.2-KS			781	372	297	41
50LVS10-10/3-62.2-KS			841	432	357	42
50LVS10-12/3-62.2-KS			901	492	417	44
50LVS10-14/3-62.2-KS	961		552	477	45	
50LVS10-16/3-62.2-KS	1021		612	537	46	
50LVS10-18/3-62.2-KS	1081		672	597	48	
50LVS10-20/3-62.2-KS	1141		732	657	49	
50LVS10-22/3-62.2-KS	1201		792	717	50	
50LVS10-5/4-63.0-KS	2		724	282	207	48
50LVS10-6/4-63.0-KS			754	312	237	49
50LVS10-8/4-63.0-KS			814	372	297	50
50LVS10-10/4-63.0-KS			874	432	357	52
50LVS10-12/4-63.0-KS			934	492	417	53
50LVS10-14/4-63.0-KS		994	552	477	54	
50LVS10-16/4-63.0-KS		1054	612	537	56	
50LVS10-18/4-63.0-KS		1114	672	597	57	
50LVS10-20/4-63.0-KS		1174	732	657	58	
50LVS10-22/4-63.0-KS		1234	792	717	60	
50LVS10-5/5-63.0-KS		2	724	282	207	48
50LVS10-6/5-63.0-KS			754	312	237	49
50LVS10-8/5-63.0-KS			814	372	297	50
50LVS10-10/5-63.0-KS			874	432	357	52
50LVS10-12/5-63.0-KS			934	492	417	53
50LVS10-14/5-63.0-KS	994		552	477	54	
50LVS10-16/5-63.0-KS	1054		612	537	56	
50LVS10-18/5-63.0-KS	1114		672	597	57	
50LVS10-20/5-63.0-KS	1174		732	657	58	
50LVS10-22/5-63.0-KS	1234		792	717	60	
50LVS10-6/6-64.0-KS	2		761	312	237	55
50LVS10-8/6-64.0-KS			821	372	297	56
50LVS10-10/6-64.0-KS			881	432	357	57
50LVS10-12/6-64.0-KS			941	492	417	59
50LVS10-14/6-64.0-KS			1001	552	477	60
50LVS10-16/6-64.0-KS		1061	612	537	61	
50LVS10-18/6-64.0-KS		1121	672	597	63	
50LVS10-20/6-64.0-KS		1181	732	657	64	
50LVS10-22/6-64.0-KS		1241	792	717	65	

<Unit: mm>

Model	Fig	L	LH	LK	Approx weight (kg)	
50LVS10-8/8-65.5-KS	3	884	372	297	83	
50LVS10-10/8-65.5-KS		944	432	357	85	
50LVS10-12/8-65.5-KS		1004	492	417	86	
50LVS10-14/8-65.5-KS		1064	552	477	87	
50LVS10-16/8-65.5-KS		1124	612	537	89	
50LVS10-18/8-65.5-KS		1184	672	597	90	
50LVS10-20/8-65.5-KS		1244	732	657	91	
50LVS10-22/8-65.5-KS		1304	792	717	93	
50LVS10-9/9-65.5-KS		3	914	402	327	84
50LVS10-12/9-65.5-KS			1004	492	417	86
50LVS10-14/9-65.5-KS	1064		552	477	88	
50LVS10-16/9-65.5-KS	1124		612	537	89	
50LVS10-18/9-65.5-KS	1184		672	597	90	
50LVS10-20/9-65.5-KS	1244		732	657	91	
50LVS10-22/9-65.5-KS	1304		792	717	93	
50LVS10-10/10-67.5-KS	3		979	432	357	92
50LVS10-12/10-67.5-KS			1039	492	417	93
50LVS10-14/10-67.5-KS			1099	552	477	94
50LVS10-16/10-67.5-KS		1159	612	537	96	
50LVS10-18/10-67.5-KS		1219	672	597	97	
50LVS10-20/10-67.5-KS		1279	732	657	98	
50LVS10-22/10-67.5-KS		1339	792	717	100	
50LVS10-12/12-67.5-KS		3	1039	492	417	93
50LVS10-14/12-67.5-KS			1099	552	477	94
50LVS10-16/12-67.5-KS			1159	612	537	96
50LVS10-18/12-67.5-KS	1219		672	597	97	
50LVS10-20/12-67.5-KS	1279		732	657	98	
50LVS10-22/12-67.5-KS	1339		792	717	100	

■ Discharge bore: 50mm, nominal flow rate: 15m³/h

•60Hz

<Unit: mm>

Model	Fig	L	LH	LK	Approx weight (kg)
50LVS15-3/1-61.5-KS	2	676	267	192	35
50LVS15-4/1-61.5-KS		721	312	237	36
50LVS15-5/1-61.5-KS		766	357	282	37
50LVS15-6/1-61.5-KS		811	402	327	38
50LVS15-7/1-61.5-KS		856	447	372	38
50LVS15-8/1-61.5-KS		901	492	417	39
50LVS15-10/1-61.5-KS		991	582	507	41
50LVS15-3/2-63.0-KS		709	267	192	48
50LVS15-4/2-63.0-KS		754	312	237	48
50LVS15-5/2-63.0-KS		799	357	282	49
50LVS15-6/2-63.0-KS	844	402	327	50	
50LVS15-7/2-63.0-KS	889	447	372	51	
50LVS15-8/2-63.0-KS	934	492	417	52	
50LVS15-10/2-63.0-KS	1024	582	507	54	
50LVS15-12/2-63.0-KS	1114	672	597	55	
50LVS15-14/2-63.0-KS	1204	762	687	57	
50LVS15-17/2-63.0-KS	1339	897	822	59	
50LVS15-3/3-64.0-KS	2	716	267	192	53
50LVS15-4/3-64.0-KS		761	312	237	54
50LVS15-5/3-64.0-KS		806	357	282	55
50LVS15-6/3-64.0-KS		851	402	327	56
50LVS15-7/3-64.0-KS		896	447	372	56
50LVS15-8/3-64.0-KS		941	492	417	57
50LVS15-10/3-64.0-KS		1031	582	507	59
50LVS15-12/3-64.0-KS		1121	672	597	61
50LVS15-14/3-64.0-KS		1211	762	687	62
50LVS15-17/3-64.0-KS		1346	897	822	65
50LVS15-4/4-65.5-KS	3	824	312	237	81
50LVS15-5/4-65.5-KS		869	357	282	82
50LVS15-6/4-65.5-KS		914	402	327	83
50LVS15-7/4-65.5-KS		959	447	372	84
50LVS15-8/4-65.5-KS		1004	492	417	85
50LVS15-10/4-65.5-KS		1094	582	507	87
50LVS15-12/4-65.5-KS		1184	672	597	88
50LVS15-14/4-65.5-KS		1274	762	687	90
50LVS15-17/4-65.5-KS		1409	897	822	92
50LVS15-5/5-67.5-KS		3	909	357	282
50LVS15-6/5-67.5-KS	954		402	327	90
50LVS15-7/5-67.5-KS	999		447	372	91
50LVS15-8/5-67.5-KS	1044		492	417	92
50LVS15-10/5-67.5-KS	1134		582	507	93
50LVS15-12/5-67.5-KS	1224		672	597	95
50LVS15-14/5-67.5-KS	1314		762	687	97
50LVS15-17/5-67.5-KS	1449		897	822	99

■ Discharge bore: 50mm, nominal flow rate: 20m³/h

• 60Hz

<Unit: mm>

Model	Fig	L	LH	LK	Approx weight (kg)
50LVS20-3/1-62.2-KS	2	676	267	192	39
50LVS20-4/1-62.2-KS		721	312	237	39
50LVS20-5/1-62.2-KS		766	357	282	40
50LVS20-6/1-62.2-KS		811	402	327	41
50LVS20-7/1-62.2-KS		856	447	372	42
50LVS20-3/2-64.0-KS	2	716	267	192	53
50LVS20-4/2-64.0-KS		761	312	237	54
50LVS20-5/2-64.0-KS		806	357	282	55
50LVS20-6/2-64.0-KS		851	402	327	56
50LVS20-7/2-64.0-KS		896	447	372	56
50LVS20-8/2-64.0-KS		941	492	417	57
50LVS20-10/2-64.0-KS		1031	582	507	59
50LVS20-12/2-64.0-KS		1121	672	597	61
50LVS20-3/3-65.5-KS	3	779	267	192	80
50LVS20-4/3-65.5-KS		824	312	237	81
50LVS20-5/3-65.5-KS		869	357	282	82
50LVS20-6/3-65.5-KS		914	402	327	83
50LVS20-7/3-65.5-KS		959	447	372	84
50LVS20-8/3-65.5-KS		1004	492	417	85
50LVS20-10/3-65.5-KS		1094	582	507	86
50LVS20-12/3-65.5-KS		1184	672	597	88
50LVS20-14/3-65.5-KS		1274	762	687	90
50LVS20-17/3-65.5-KS		1409	897	822	92
50LVS20-4/4-67.5-KS	3	864	312	237	88
50LVS20-5/4-67.5-KS		909	357	282	89
50LVS20-6/4-67.5-KS		954	402	327	90
50LVS20-7/4-67.5-KS		999	447	372	91
50LVS20-8/4-67.5-KS		1044	492	417	91
50LVS20-10/4-67.5-KS		1134	582	507	93
50LVS20-12/4-67.5-KS		1224	672	597	95
50LVS20-14/4-67.5-KS		1314	762	687	96
50LVS20-17/4-67.5-KS	1449	897	822	99	

2.6 Internal structure drawing (Example)

- 32LVS1, 32LVS3, 32LVS5 (4.0kW or less)

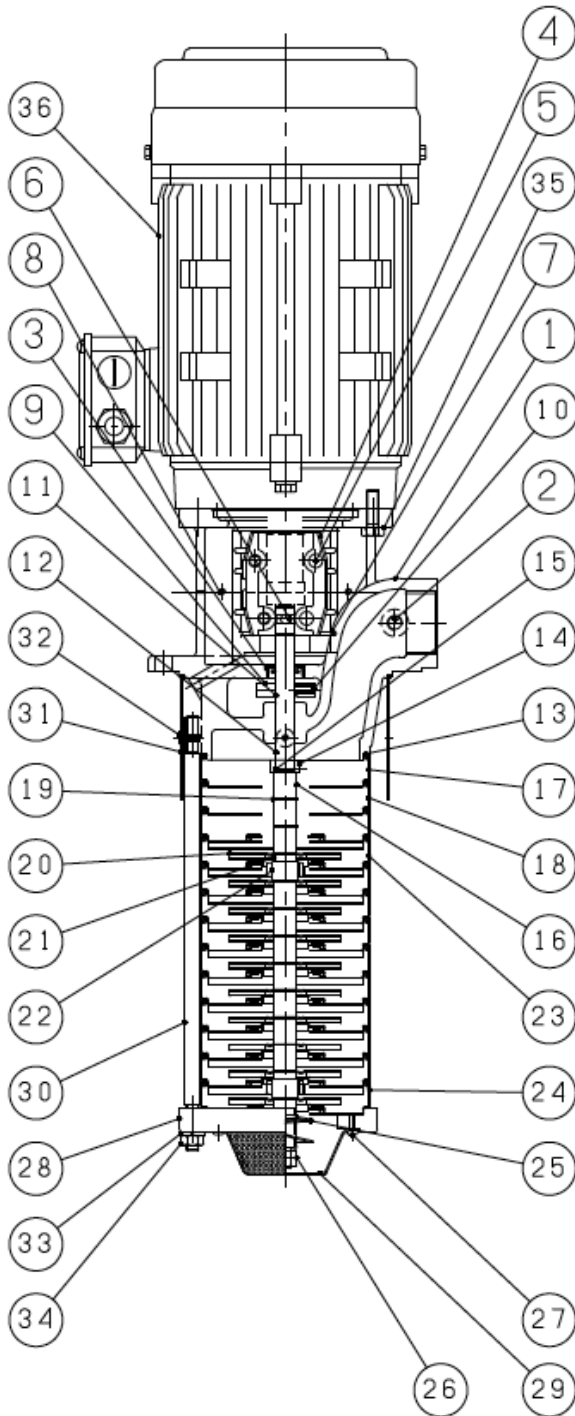

No.	Part name	Material
1	Discharge casing	FC200
2	Air vent valve	Brass
3	Oil seal	NBR
4	Coupling	FCO205
5	Hexagon socket head cap screw	SCM435
6	Shaft pin	SUS316
7	Coupling cover	SUS304
8	Cross recessed pan head screw	SUS304
9	Slinger	SUS304
10	Set screw	SCM435
11	O-ring	FKM
12	Main shaft	SUS420J2
13	Gasket	-
14	Shaft bushing	SUS304
15	Shaft ring	SUS316
16	Sleeve	SUS304
17	Interstage casing (last stage)	SUS304
18	Interstage casing	SUS304
19	Shim	SUS304
20	Impeller	SUS304
21	Baffle	SUS304
22	Bearing	SiC
23	Bearing casing	SUS304+SiC
24	Interstage casing (first stage)	SUS304
25	Screw	SUS304
26	Hard locknut	SUS304
27	Cross recessed pan head screw	SUS304
28	Suction casing	FC200
29	Strainer	SUS304
30	Through bolt	SUS304
31	Outer sleeve	SUS304
32	Cross recessed countersunk head screw	SUS304
33	Spring washer	SUS304
34	Hexagon nut	SUS304
35	Hexagon bolt	SUS304
36	Motor	-

[Note] The parts are made of materials equivalent to those shown in the table.

Typical models are shown in these figures. The shapes may be slightly different depending on the model and specifications. Because some of the specifications may be changed due to design changes or for other reasons, refer to the delivery specifications when planning your pumping work.

- 50LVS10 (5.5kW or more), 50LVS15 (5.5kW or more), 50LVS20 (5.5kW or more)

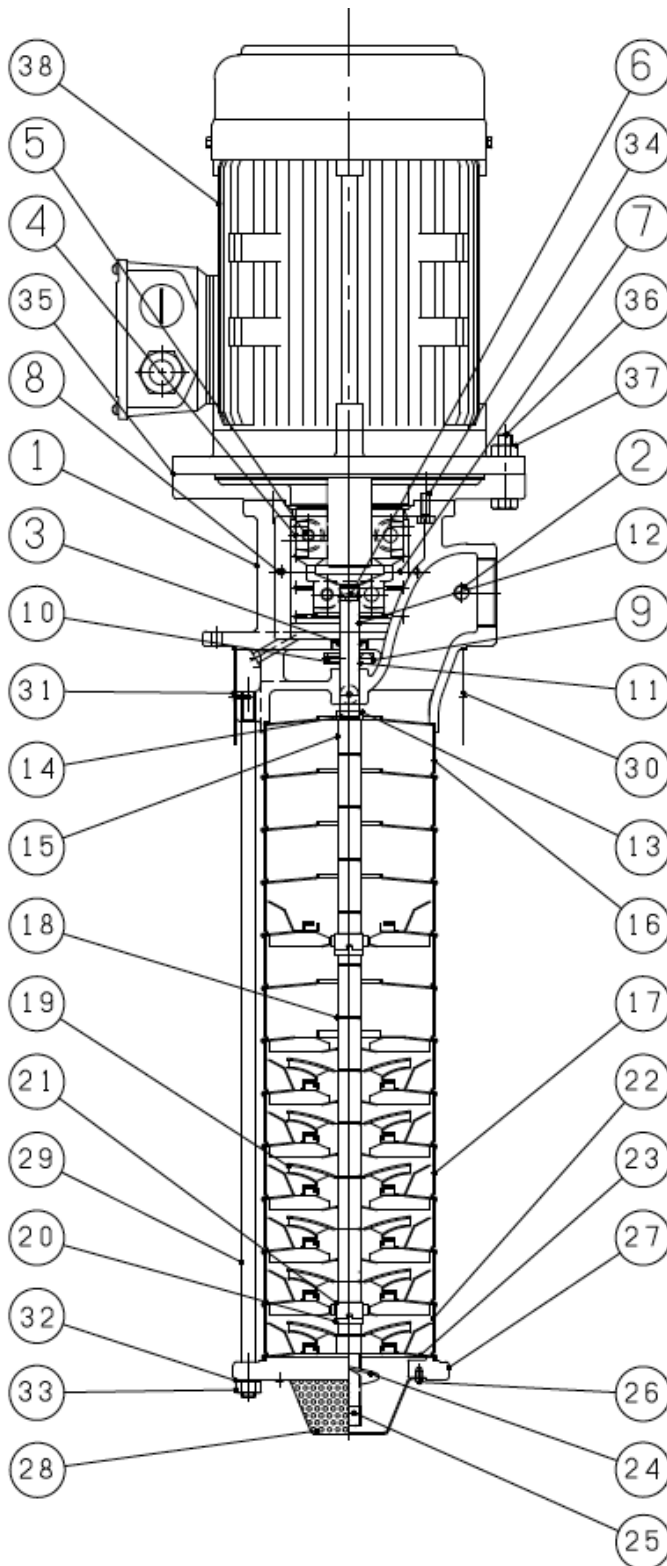

No.	Part name	Material
1	Discharge casing	FC200
2	Air vent valve	Brass
3	Oil seal	NBR
4	Coupling	FCO205
5	Hexagon socket head cap screw	SCM435
6	Shaft pin	SUS316
7	Coupling cover	SUS304
8	Cross recessed pan head screw	SUS304
9	Slinger	SUS304
10	Set screw	SCM435
11	O-ring	FKM
12	Main shaft	SUS420J2
13	Shaft bushing	SUS304
14	Shaft ring	SUS316
15	Sleeve	SUS304
16	Interstage casing (last stage)	SUS304
17	Interstage casing	SUS304
18	Shim	SUS304
19	Impeller	SUS304
20	Baffle	SUS304
21	Bearing	SiC
22	Bearing casing	SUS304
23	Interstage casing (first stage)	SUS304
24	Screw	SUS304
25	Hard locknut	SUS304
26	Cross recessed pan head screw	SUS304
27	Suction casing	FCD400
28	Strainer	SUS304
29	Through bolt	SUS304
30	Outer sleeve	SUS304
31	Cross recessed countersunk head screw	SUS304
32	Plain washer	SUS304
33	Hexagon nut	SS400
34	Hexagon bolt	SS400
35	Frame spacer	SUS304
36	Hexagon bolt	SUS304
37	Hexagon nut	SUS304
38	Motor	-

[Note] The parts are made of materials equivalent to those shown in the table.

Typical models are shown in these figures. The shapes may be slightly different depending on the model and specifications. Because some of the specifications may be changed due to design changes or for other reasons, refer to the delivery specifications when planning your pumping work.

3. Transportation, conveyance, storage and installation

3.1 Precautions for transportation, moving and storing the pump

- (1) Do not unpack the container unnecessarily.
If you unpack the container unnecessarily, securely pack again in such a manner that the product body does not jump out of it and fall down during transportation, conveyance or storage.
- (2) When you transport, move, or store the pump, ensure that the pump is located in a well-ventilated place with minimum exposure to dust and moisture in an environment at an ambient temperature of -25 to 55 degrees Celsius and humidity of less than 85%RH. The packing materials, made mainly of corrugated cardboards, break more easily when they absorb moisture.
- (3) Check the orientation of the container and then place it in the correct orientation (not upside down).
- (4) Do not stack the containers of the product more than the allowable number of units indicated on the packing material.
- (5) Use extreme care so as not to give an impact or offset load to the pump during conveyance or transportation. The container may greatly incline depending on its center of gravity.



Before transporting or moving the product, confirm the weight of each unit by referring to the catalog, dimensional outline drawing, and other documents, and then determine the appropriate method.



When you lift the product by hand, pay attention to its center of gravity and weight. Do not allow a single person to lift a product heavier than 15 kg. Otherwise, it may put strain on the body, thus leading to an injury.

3.2 Before using the pump

Upon receiving the pump, check the following points first.

If you find any problems, contact the vendor from which you purchased the product.



Before unpacking the delivered container, check that the container is placed in the correct orientation (not upside down). Pay special attention to nails especially when opening a wooden crate. Otherwise, you may get injured.

- (1) Check the nameplate to verify that the delivered product is exactly what you ordered. (Refer to 2.4. Information indicated on the nameplates. [page 2-3].)
- (2) No part of the product is damaged during transportation.
- (3) All fastening parts including bolts and nuts are securely tightened.
- (4) All the accessories that you ordered have been delivered.

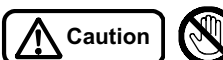

When you handle the pump, do not hold the strainer located on the tip of the pump. Otherwise, the strainer may come off, thus leading to an injury or damage.



Do not run a pump power supply at 60Hz. Otherwise, it may lead to overload and motor burnout.
Running a 60Hz pump at 50Hz reduces its performance.

3.3 Precautions for installation



Before turning the pump shaft by hand to check its rotation, be sure to turn off the main power. Otherwise, an unexpected start of the pump may cause an accident.

- (1) Install the product in a well-ventilated place with minimum exposure to dust and moisture. (Refer to the Installation location in “2.3. Standard specifications [page 2-2]”). In particular, avoid installing the product in a place where the pumping liquid may be splashed on the motor section.



Do not install the product in a hot or humid place.
Otherwise, it may lead to heating, ignition or electric leak.

- (2) Install the product so that the motor can take air in.
- (3) Securely install the product on a flat place without any wobbles.
- (4) The mounting surface must be strong enough to prevent the amplification of vibrations while the pump is running.
(Restrict the total amplitudes in X, Y, and Z directions [see the right figure] to 33 μm at 50 Hz and to 29 μm at 60Hz during the operation of the pump.)

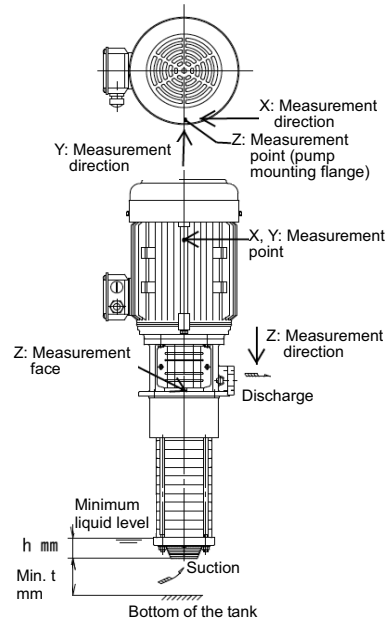

- (5) Select a convenient place to conduct maintenance and inspection. Secure space for maintenance.
- (6) It is necessary to make a mounting hole larger than the outside diameter of the pump section so that the pump section can fit into the tank (oil tank). See the dimensional outline drawing.
- (7) Install the pump so that its main shaft is located in a vertical position.
- (8) For the operation, the pump section needs to be submerged below the liquid level. To prevent the strainer from getting clogged with cutting powder, dirt, or other materials, keep the suction port at least t mm (shown in the following table) away from the bottom surface of the tank (oil tank). If cutting powder, dirt, or other materials are predicted to accumulate on the bottom of the tank, provide as large a distance as possible (at least t mm) from the bottom at the design stage.

Model	h	t
32LVS	42	5
50LVS	75	20

Note

Always keep the liquid level in the tank (oil tank) above the Minimum liquid level.
Keep the suction port of the pump at least t mm away from the bottom of the tank (oil tank).

- (9) The product is coated. If you need to overcoat it in a different color for a compelling reason, lightly roughen the product surface with sand paper or the like and then coat it, which improves the adhesion properties of the coating film. (Be sure to check the overcoatability of the paint.)
- (10) Do not install the product in a place where a secondary hazard could occur in the event of any liquid leak.
- (11) If the system could be exposed to the freezing temperature in winter, be sure to apply antifreeze measures such as heat insulation or the installation of a heater to the pump, valves, or piping.
- (12) Securely install the pump. Recommended size of pump mounting bolt: M6 for 32LVS, M8 for 50LVS

Note

Securely fix the pump in place with the bolts. Otherwise, it may lead to abnormal vibration or other problems.

- (13) When hoisting the pump, remove the coupling cover, pass a nylon sling or the like through the lifting points of the pump, and then hoist the pump. Do not hoist the equipment with the pump attached. Otherwise, it may damage the hoisting equipment/devices and the pump may fall.
- (14) When you hoist or move the pump, be sure to handle the pump carefully so that the pump section would not be subjected to an impact or imbalanced load. The unit may greatly tilt depending on its center of gravity.



Before hoisting the pump, refer to the catalog, dimensional outline drawing, and other documents to check the weight of the units. Do not hoist any units if its weight exceeds the rated load of the hoisting equipment/devices.



Never use a pump or install parts on it when the pump is hoisted. Otherwise, the pump may fall.

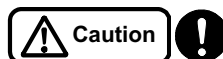

When hoisting the pump, pay attention to its center of gravity. Otherwise, the pump may topple over or fall, thus leading to an injury.



When you lift the product by hand, pay attention to its center of gravity and weight. Do not allow a single person to lift a product heavier than 15 kg. Otherwise, it may put strain on the body, thus leading to an injury.

- (15) If the pumping liquid is cold, condensation may occur inside the motor while the pump is stopped. Take measures to prevent condensation, for example, by installing the pump in a sufficiently dry room or by heating and insulating the motor even when the pump is stopped.
- (16) Carry out touchup painting at a time interval suitable for the environment of use. Depending on the humidity, condensation, and other conditions, rust may form on areas such as threaded parts, worked areas, anticorrosive-coated sections.
- (17) Do not put a cover or filter over the motor. Otherwise, the temperature may increase inside the motor, thus leading to product damage, fire, or other problems.

3.4 Precautions for piping work

- (1) The pipes must be as short and straight as possible with minimal joints and valves. Use pipes whose bore size is equal to or larger than the discharge port of the pump. If the piping size is small or there are many bends, the discharge rate may become low.
- (2) Ensure to provide adequate pipe supports so that the weight of the piping system will not be applied directly to the pump body.

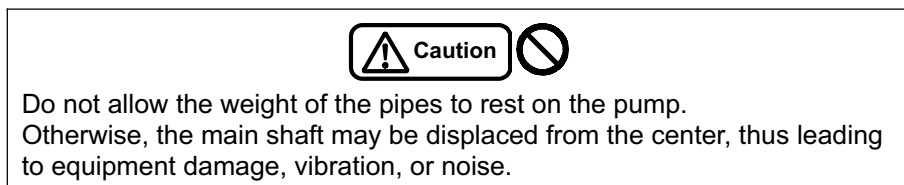

- (3) Do not forcibly screw a pipe into the pump. Otherwise, it may break the joint.
- (4) Securely connect the pipes so that the connections are kept completely airtight without leakage. Prevent leaks of liquid and air with seal tape, liquid packing, or other means. Firmly wind the seal tape while paying attention not to block the piping.
- (5) Use a tank (oil tank) with as large a capacity as possible.
 - * It is recommended to use a capacity of at least three times the discharge volume per minute. Too small a capacity may cause problems such as the rise of liquid temperature, premature strainer clogging with cutting powder, and lower discharge rate caused by bubbles. When you supply a pumping liquid into a tank (oil tank), gently pour it to prevent the introduction of air.
- (6) Do not allow a large amount of cutting powder, dirt, or other contaminants from entering the pump section. Otherwise, it may clog the pump strainer, damage the pump, or significantly deteriorate the performance. Use liquids that are subjected to secondary treatment through a net cage, a chip conveyor, a magnetic separator, etc.
- (7) If water hammer may occur, attach a pressure damper (e.g. accumulator).
- (8) If there is an upward curve on the discharge pipe, ensure that air can be vented from the section.
- (9) If you provide a relief pipe on the discharge side of the pump, also provide a sluice valve in the middle of the relief pipe to adjust the relief volume.

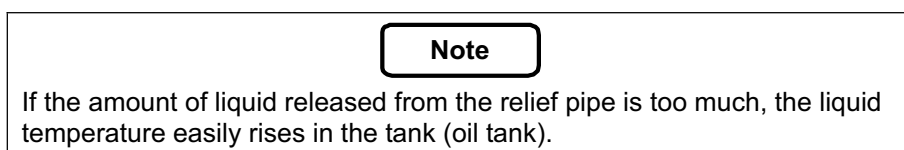

- (10) On completion of the piping work, be sure to clean the tank (oil tank). Pay attention not to contaminate the system with foreign matter.

3.5 Precautions for wiring work

 **Danger**

Use high-quality wiring equipment and devices, and carry out wiring work safely and securely according to the technical standards for electrical facilities, as well as the indoor wiring regulations. Only qualified personnel such as licensed electrical engineers are allowed to carry out electrical wiring work. Unqualified persons are prohibited by law to carry out wiring work, and it is very dangerous.

 **Danger**

Securely connect the terminals of the power cable. Loose terminals may cause the motor to run in open-phase condition, thus leading to motor burnout.

- (1) For the size of the power cable, refer to the following:

Output [kW]	Minimum size of the cable (200-volt class)
0.75 to 4.0	1.6 mm
5.5	2.0 mm
7.5	5.5 mm ²

- (2) Be sure to install a ground fault interrupter and an overload protection device on the primary power side of the pump.

* The starting current of Top Runner Energy Efficiency Standards (equivalent to IE3) motor-equipped products tends to become higher than that of standard efficiency (IE1) motor-equipped products. Therefore, when you switch from an IE1 motor-equipped product, it is necessary to verify the applicability of its ground fault interrupter and overload protection device. Refer to the “Starting electric current” and “Rated electric current” specified in “0. Specification table [page 2-4].” If you have any questions, contact Teral.

Note

When you switch from an IE1 motor-equipped product, it is necessary to verify the applicability of its protection device on the primary side of the pump. Otherwise, the protective device may be tripped on startup.

- (3) Securely connect to the power by wiring the terminals according to the following figure (standard voltage product). Be sure to attach a ground wire to prevent an electric shock. Connect the ground wire to the ground terminal inside the terminal box of the motor.

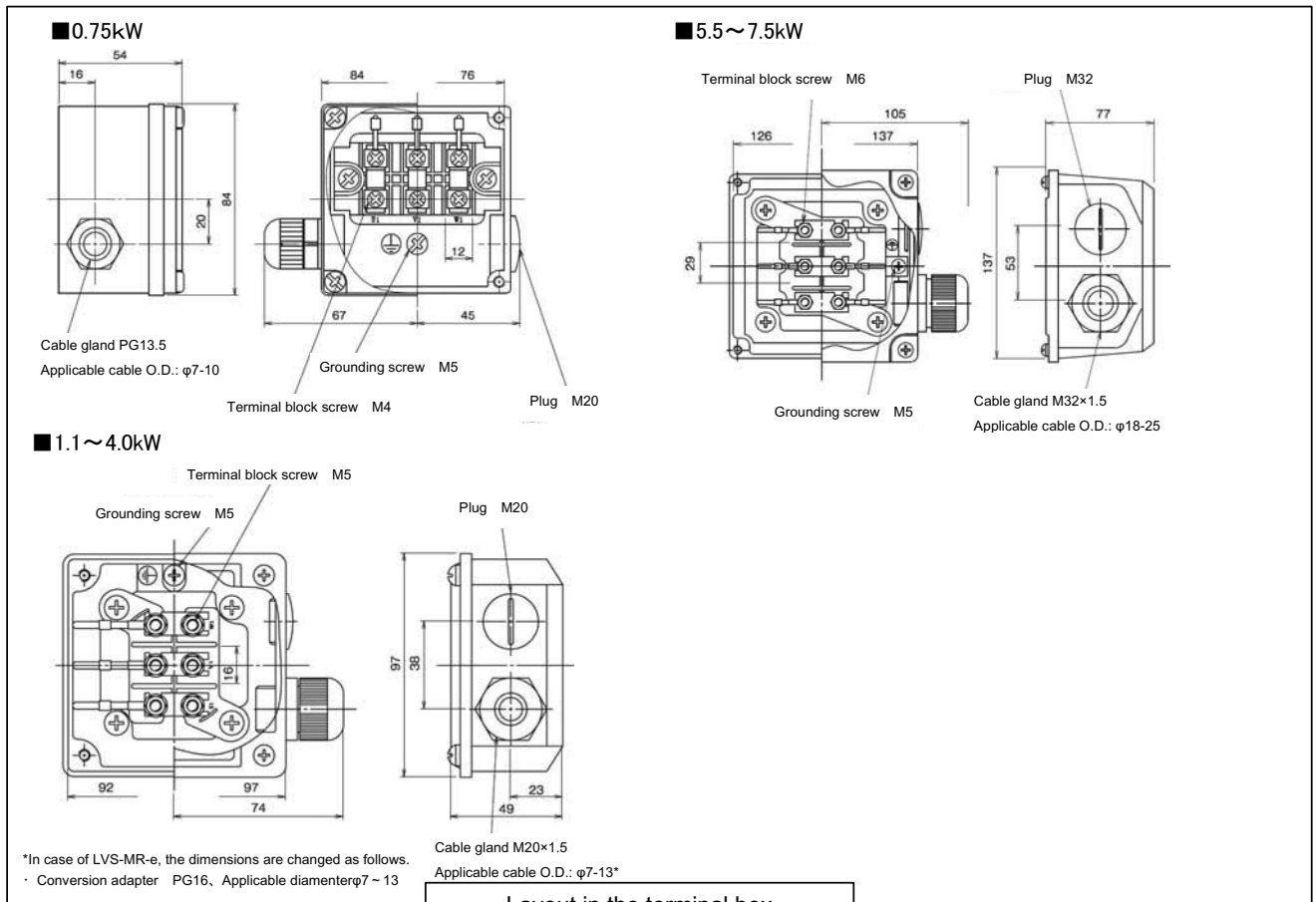

Layout in the terminal box

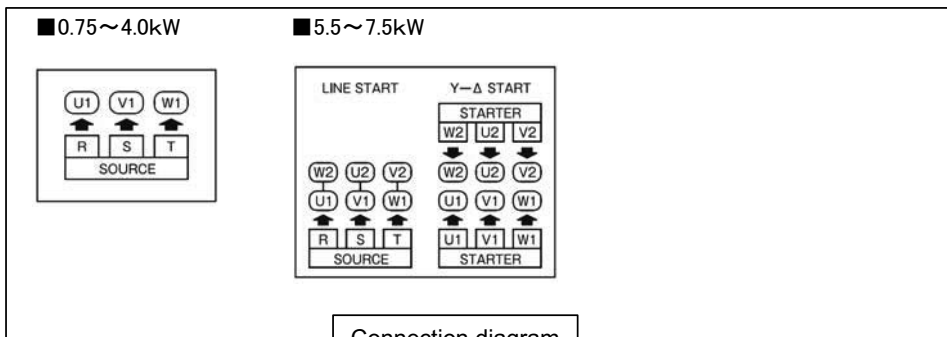

Connection diagram

Warning

Connecting a ground wire to a gas pipe or water pipe is illegal and extremely dangerous.

- (4) To prevent the terminal block of the motor from being pulled, fasten the power cable to the terminal box with the cable lock.

Warning

Do not change the orientation of the terminal box. Otherwise, liquid may enter the terminal box, thus leading to an electric shock.

- (5) To prevent overload and burnout of the motor, it is recommended to use a thermal relay for motor protection.

- (6) Take adequate dust-proofing and drip-proofing measures using a connector, gland, or other means to prevent any cutting powder and liquid coolant from entering the terminal box through the external wiring hole.
- (7) Pass the power cable through a metal tube or a metal conduit for shielding, and connect a ground wire to the outer surface of the tube.
- (8) Limit the fluctuations of the supply voltage within $\pm 10\%$ of the rated voltage, and also limit the fluctuations of the frequency between -5% and $+3\%$ of the rated value. Although you can run the pump in these ranges, avoid continuous operation if the voltage is not within $\pm 5\%$ of the rated value or if the frequency is not within $\pm 2\%$ of the rated value. Otherwise, it may overload the pump, thus leading to motor damage or a fire.

Even if the power fluctuations fall within the allowable ranges, the pump characteristics, motor characteristics, and the temperature rise of the motor may differ from those at the rated voltage and frequency.

(9) Precautions for using the inverter drive

- Ensure that the electric current during operation does not exceed 90% of the rated value.
- Ensure that the minimum frequency is set to 20Hz.
(Contact us if you need to run the drive at 20Hz or lower.)
- Contact us when using a 400V class model. Protective measures may be required against inverter surge.
- An inverter-driven motor generates a magnetic sound which may be annoying compared with the drives using commercial power supply. Although this magnetic sound does not cause an adverse effect on the quality of the motor, some inverters allow the user to adjust the tone by changing the carrier frequency. However, changing the frequency may reduce the allowable output of the inverter. Pay particular attention when selecting an inverter.
- If the pump and motor produce resonance during normal operation, do not run them in the range of the rotation speed.



Do not run a pump power supply at 60Hz. Otherwise, it may lead to overload and motor burnout.
Running a 60Hz pump at 50Hz reduces its performance.

4. Operation

4.1 Check items before test operation

4.1.1 Check items related to the electrical system

- (1) Check that the equipment is correctly wired.
- (2) Check that the terminals are securely connected.
- (3) Check that the equipment is securely grounded.
- (4) Check that the setup value of the overload protection device is consistent with the rated current value of the motor.



Do not use the product at any voltage other than the rated value. Otherwise, it may lead to a fire or electric shock.

4.1.2 Check items related to the pump



Do not run the pump with its coupling cover or strainer removed. Otherwise, it may lead to an injury or damage.

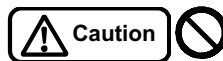

Do not allow a large amount of foreign matter to enter the pump. Otherwise, it may damage the sliding parts (e.g. bearings, mechanical seal) inside the pump, or lead to leakage or unusual noise.

- (1) Check that the liquid level in the tank (oil tank) is above the "Minimum liquid level."



During test operation, never run the pump dry (i.e. running the pump when the liquid level is below the Minimum liquid level). During normal operation, do not run the pump dry for more than 30 seconds. Otherwise, it may seize up the sliding parts inside the pump.

- (2) Check the rotation direction. Normal rotation is counterclockwise when viewed from the motor side. (See the right figure.)
- (3) Turn the main shaft by hand to check smooth rotation. To do that, remove the coupling cover and then turn its shaft by holding the coupling. The rotation must be smooth without binding (no sticking points). If the rotation is stiff or not uniform, there may be some rust or foreign matter inside the pump. Inspect the pump in such a case.

Rotation direction

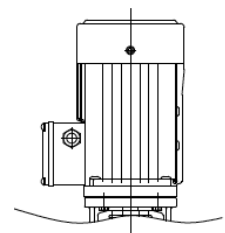
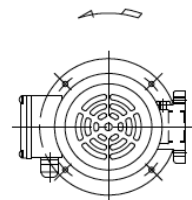

Before turning the pump shaft by hand to check its rotation, be sure to turn off the main power. Otherwise, an unexpected start of the pump may cause an accident.

- (4) Open the air vent valve to release air. After the air release, close the air vent valve. If no air vent valve is provided, open the valve on the discharge piping to release air.



(5) If you run the motor at variable speed with the inverter, be sure to check the following points through test operations.

- The pump may produce resonance depending on installation conditions. If the pump produces resonance, avoid that frequency.
- If the operation frequency is low or the dynamic viscosity of the pumping liquid is high, the pump may not discharge any liquid.
- Do not run the pump at a power frequency exceeding 60Hz. Otherwise, the motor may burn out.

 **Caution** 

Do not run a pump power supply at 60Hz. Otherwise, it may lead to overload and motor burnout. Running a 60Hz pump at 50Hz reduces its performance.



4.2 Running the pump (test operation)

 **Warning**  

Be sure to attach the cover of the terminal box of the motor. Otherwise, it may lead to an electric shock.

 **Warning**  





Be sure to keep the coupling cover attached during the operation of the pump. Otherwise, it may lead to an injury.

 **Warning** 

Do not operate the pump if any abnormal condition is observed or if there is anything wrong with the parts, components, and others during the check before test operation. Otherwise, it may lead to an injury, failure, accident, or other problems.

 **Warning**   

If you pump a liquid over 40°C, do not touch the pump. Otherwise, its hot surface may cause burns.

 **Warning**   

Do not touch the motor during operation or immediately after the stop of operation. Otherwise, its hot surface may cause burns.

- (1) Check the rotation direction of the pump by turning on and off the power switch once or twice. Normal rotation is counterclockwise when viewed from the motor side. If the pump rotates in reverse, swap two of the three wires of the power cable.



Never check the rotation direction by running the pump dry even for a short time. Otherwise, it may damage the sliding parts (e.g. casing, bearings) in the pump, or lead to leakage or unusual noise.



Do not run the motor in reverse because it may cause a failure.



Do not run the pump dry, and do not allow a large amount of air or foreign matter from entering the pump. Otherwise, it may damage the sliding parts (e.g. bearings) in the pump, make it impossible to pump up liquid, or lead to leakage or unusual noise. It may also heat the pump, thus leading to burns.

- (2) If your pump is provided with an air vent valve, slightly open the valve upon startup, and confirm that liquid is discharged. Once you have confirmed the discharge, ensure to close the air vent valve.

Note

If the motor output and the discharge rate are both large and the tank (oil tank) capacity is small, the liquid temperature may rise in the tank and exceed the rated liquid temperature.

- (3) Turn on the power to start the pump.
- (4) During the initial period of pump operation and circulation, gradually open the sluice valve on the discharge side to circulate liquid at a flow rate (flow velocity) higher than the normal operation.
- (5) Adjust the sluice valve on the discharge side so that the specified pressure is achieved. Do not perform zero-discharge operation for more than 5 minutes in a row. Long hours of zero-discharge operation increase the liquid temperature in the pump. Therefore, allow a small amount of liquid to flow (at least 10L/min); or if you no longer use the liquid, stop the pump. Too hot liquid may reduce the service life of the motor or damage the shaft seal.



Do not perform zero-discharge operation for more than 5 minutes in a row. Otherwise, the liquid temperature may increase in the pump, thus leading to an unexpected failure.

- (6) Because this pump is structured without any mechanical seal (no sealing device at the shaft seal), some liquid is discharged from the outer cylinder of the pump, but it is not a product defect.
- (7) When the liquid level is too low, the pump may take air in and decrease the discharge rate, thus making it impossible to pump the liquid. Keep the liquid level above the Minimum liquid level indicated in the Dimensional outline drawing. Note that, however, this liquid level changes depending on the viscosity and liquid surface condition. For safety, set the liquid level high enough, but at a level below the "Maximum liquid level" indicated in the outline drawing.





(8) Limit the frequency of the startups and shutdowns according to the following table:

Model	Allowable frequency of startups (times/hour)
LVS (4.0 kW or less)	60
LVS (5.5 to 7.5 kW)	20



Minimize the frequency of startups and shutdowns of the pump because their high frequency may quickly damage the pump.

(9) In the event of a power failure during operation, be sure to turn off the power.

In the event of a power failure, be sure to turn off the power switch. Otherwise, the pump may suddenly start up on restoration of the power, thus leading to an injury.

(10) Before restarting the pump, confirm that the pump has stopped completely.



Before restarting the pump, be sure to check that the pump has stopped completely. Turning on the power while the pump is still rotating causes an excessive torque on the pump and may cause a failure.

(11) Avoid sudden pressure fluctuations during the operation of the pump.

(12) Check for any abnormal pressure, electric current, vibration, noise, and other abnormal conditions. If you find any abnormal conditions, take appropriate actions after checking the Section “6. Troubleshooting [page 6-1].”

Refer to the following chart for vibration vs. rotation speed.

(13)

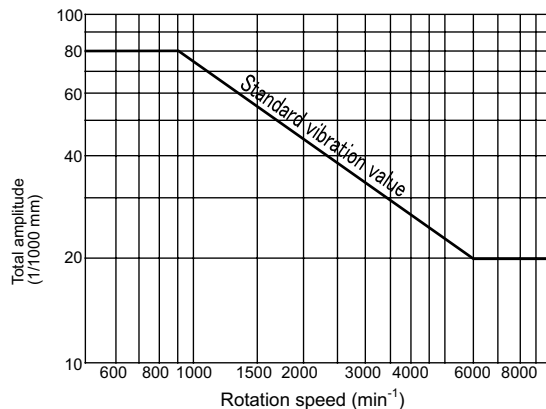

Standard vibration value at the bearing section

[For reference only]

Relation between the total amplitude (a) and the vibration velocity (V)

$$a = \frac{V \times 6 \times 10^4}{\pi \times n}$$

- a: Total amplitude (µm)
- V: Vibration velocity (mm/s)
- n: Equipment rotation speed (min⁻¹)

Do not allow a large amount of cutting powder to enter the pump. Otherwise, it may lead to the clogging of the pump strainer or impeller, thus decreasing the discharge rate. For the LVS coolant pumps, use liquids that are subjected to secondary treatment through a net cage, a chip conveyor, a magnetic separator, etc. Cutting powders that are small enough to pass through the pump strainer can damage the pump or significantly deteriorate the performance. If you use the pump in processes such as grinding, milling, or end milling in which a large amount of cutting powder is discharged, select the pump carefully.

(14) Stop the pump.



Keep the cocks of the pressure gauges, compound pressure gauges, and other parts closed all the time except when they are used for measurement. Otherwise, they are more prone to fail.



Do not run the pump using the power beyond the allowable current value. Otherwise, the motor may burn out. For the allowable current value, see the characteristic curve.



Do not put your fingers or other objects into the opening of the motor. Otherwise, it may lead to an electrical shock or injury.

5. Maintenance and inspection



Before checking the pump, be sure to turn off the main power. Otherwise, the pump may suddenly start up in automatic mode or on other occasions, thus leading to great danger.



Before starting the unit or carrying out maintenance/inspection work, ensure that all the relevant workers are informed of the operation and that there are no workers in the dangerous zone.



For overhaul, replacement of parts, or repairs, ask the vendor or the service center specified by Teral. Incorrect work may cause a failure or accident.

5.1 Precautions for maintenance and inspection

(1) Observe the following points, in particular, during daily inspection.

- ① A large deviation in the pump's discharge pressure, electric current, vibration, noise, or other conditions from the normal status is a sign of an imminent failure. Therefore, immediately take measures, referring to the Maintenance checklist in Section "5.5. Periodic inspection [page 5-4]." For this purpose, it is recommended to keep an operation log.
- ② If the bearing temperature gets abnormally high, immediately stop the pump and check the bearing. The temperature is normal if the temperature difference between the motor surface and the atmosphere does not exceed 40°C.
- ③ Because prelubricated shielded bearings are used for the 7.5kW or lower output models, there is hardly any need for maintenance of the bearings such as refilling of grease. Replace the bearings if they generate unusual noise or vibration.
 - * Urea grease is adopted for lubrication inside the bearings to extend their service life. Use bearings into which urea grease is filled.
 - * The fan is connected to the motor by interfere fit. Once removing the external fan, exchange it with a new one.
- ④ An oil seal is attached to the bearing section to prevent the entry of liquid. When you replace a bearing, also replace its oil seal with a new one.

Model	Oil seal type
	Pump section
32LVS-KS	IS12257
50LVS-KS	SC16328

* For the oil seal type of the motor section, refer to "5.3 Motor bearing [page 5-3]."

- ⑤ Keep the cocks of the pressure gauges and compound gauge closed all the time except when inspection is required.
- ⑥ In the event of a power failure, be sure to turn off the power. The pump suddenly starts up on restoration of the power, thus leading to danger.



In the event of a power failure, be sure to turn off the power switch. Otherwise, the pump may suddenly start up on restoration of the power, thus leading to an injury.

(2) If you do not use the pump for a long time, observe the following points:



Caution

If you do not use the pump for a long time, turn off the power for safety. Otherwise, accumulated dust may cause heating or ignition.

- ① To prevent possible freezing inside the pump in winter, be sure to take antifreeze measures—such as heat insulation or the installation of a heater to the pump—or completely drain the pump.
- ② If you have a backup pump, run it from time to time to make it available for operation at any time.

5.2 Tightening the coupling

- (1) After loosely fixing the coupling in place by passing the pin through the main shaft, lift the coupling with a flat-blade screwdriver or the like, and tighten the coupling at midpoint between the upper and lower limits. When you tighten the coupling, ensure to make the gaps of the coupling even. Before you remove the coupling, you could draw a line at the coupling position on the pump shaft with a marker pen or others to use it as a guide for positioning. If you run the pump with the coupling fixed at the upper or lower limit, you may damage the pump.
- (2) Insufficient torque of the screws for coupling may damage the pump. Therefore, tighten them according to the torque shown in the following table.

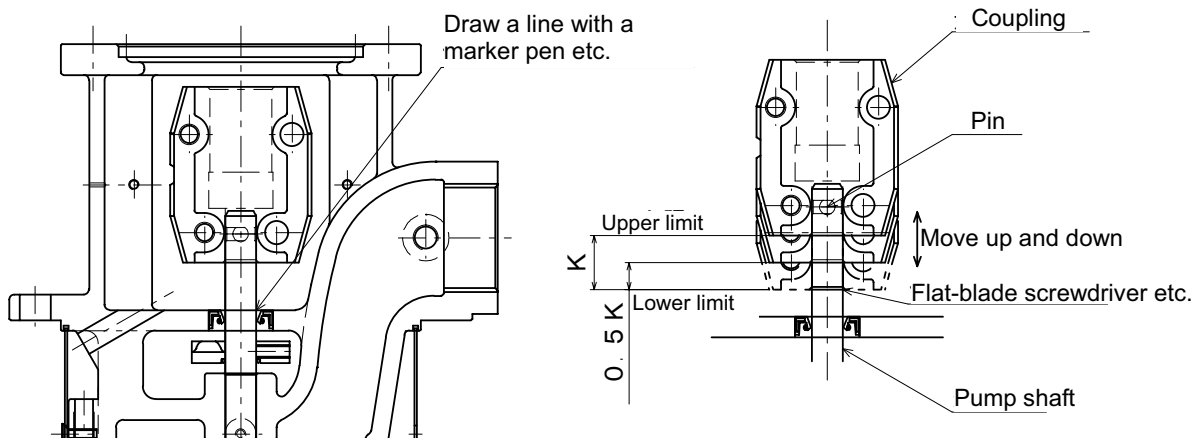

Tightening torque of screws for coupling

Motor output (kW)	Screw size	Tightening torque (N·m) {kgf·cm}
0.75 to 1.1	M6	13 {130}
1.5 to 4.0	M8	30 {300}
5.5 to 7.5	M10	62 {620}

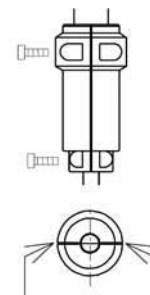

Make the gaps even.

5.3 Motor bearing

For the bearing type, refer to the following table.

* You can't use non-standard motor.

Bearing/Oil seal type

Motor output [kW]	Bearing type		Oil seal type	
	Load side	Non-load side	Non-load side	Load side only
0.75	6204 ZZ C3	6201 ZZ C3	-	-
1.1	6204 ZZ C3	6304 ZZ C3	-	-
1.5	6205 ZZ C3	6304 ZZ C3	VC 25 40 7	VC 20 40 7
2.2	6205 ZZ C3	6304 ZZ C3	VC 25 40 7	VC 20 40 7
3.0	6307 ZZ C3	6305 ZZ C3	VC 35 55 7	VC 25 47 7
4.0	6307 ZZ C3	6305 ZZ C3	VC 35 52 7	VC 25 40 7
5.5	6309 ZZ C3	6306 ZZ C3	VC 45 62 8	VC 30 52 8
7.5	6309 ZZ C3	6306 ZZ C3	VC 45 62 8	VC 30 52 8

5.4 Daily inspection

Upon startup and during operation, check the pump for any abnormal conditions in terms of its discharge pressure, electric current, vibration, noise, and others.

5.5 Periodic inspection

- (1) Clean any dirt, oil, and other deposits off the outer surface of the coolant pump.
- (2) Cutting powder deposited in the tank (oil tank) may cause a pump failure. Periodically clean the tank (oil tank).
- (3) Check the strainer of the pump for any clogging. Clean it if it is clogged.



Periodically clean the strainer located on the pump suction side. A clogged strainer may cause pressure fluctuations, a lower discharge rate, unusual noise, and other problems, thus leading to a pump failure.

- (4) For other inspection items, refer to the Maintenance checklist.

Maintenance checklist

Item	Inspection point	Inspection item	Inspection method	Criterion (Reference page)	Inspection interval				Timing of replacing consumables (as a guide)*1	
					Daily	Monthly	Half-yearly	Yearly		
Ambient conditions	Temperature	Check against the specified range.	Measure	Between 0 and 40°C (2-2)	✓				-	
	Humidity		Measure	85%RH or less (2-2)	✓				-	
	Dust and other contaminants		Visual check	No dust or other contaminants	✓				-	
Power	Power terminal block	Voltage	Measure	Specified voltage (2-2)			✓		-	
		Voltage fluctuation	Measure	Within the allowable fluctuation range (3-5)			✓		-	
		Loose screws	Tighten	Securely tightened				✓	-	
Pump and motor	Impeller	Clogging	Disassemble and inspect	No clogging				✓	-	
		Wear	Disassemble and inspect	No abnormal condition				✓	When worn out	
	Main shaft and its surrounding area	Smooth rotation	Rotate by hand	Rotation is smooth and uniform (4-1)				✓	-	
	Bearing (motor) *2,*3	Heat	Touch	Not unusually hot (5-1)				✓	1 to 2 years	
		Greaser refilling	Visual check Listen	No abnormal vibration/ noise, No outflow of grease					Refer to 5-3 for grease refilling amount and intervals.	
	Submerged bearing (bearing ring and sleeve)	-	-	No abnormal condition				✓	2 to 3 years	
	Rubber parts	O-rings	-	-	-				✓	Whenever disassembled
		Oil seals, etc. *3	-	-	No abnormal condition				✓	1 to 2 years
	Others (screws etc.)	-	-	No abnormal condition					As needed	
	Appearance	Unusual noise, vibration	Listen Visual check	No abnormal condition	✓				-	
Insulation resistance	Between the ground and each lead wire	Megger tester	1 MΩ or more				✓	-		

*1 The timing of replacing consumables (as a guide) does not mean their guaranteed service life. The service life of parts varies depending on the ambient conditions and the conditions for use.

*2 Urea grease is adopted for lubrication inside the bearings to extend their service life. Use a bearing into which urea grease is filled.

*3 A motor shaft is driven in to fit to the cooling fan. Therefore, if you take the fan off, replace it with a new one.

6. Troubleshooting

The following table lists causes of failures and their actions. In the event of a failure, however, you should carefully investigate the problem and ask the vendor to carry out any actions that are not easy to take.

Problem	Cause (Reference page)	Action (Reference page)	Done by *
The pump does not start.	Wiring is disconnected or broken. (3-4)	Check the wires and connections. Repair or replace.	Vendor
	The power fuse is blown.	Replace it with an appropriate fuse.	User
	Tripping of the thermal relay	Check the thermal relay.	User
	Poor connection or contact of power wires (3-4)	Check the wires and connections.	Vendor
	The power voltage is too low. (3-5)	Check the power voltage. Contact the power company.	User
	The motor has failed. (e.g. broken wire of the stator winding)	Repair at vendor's shop. Contact the vendor because disassembly and inspection are required.	Vendor
	Foreign matter is caught in the impeller.	Disassemble, clean, and repair. Contact the vendor because disassembly and inspection are required.	Vendor
	The sliding parts (metallic part of bearing) have seized up.	Disassemble and check. Contact the vendor because disassembly and inspection are required.	Vendor
Overload and overcurrent of the motor	The bearing is rusty. (5-1)	Replace the bearing. (5-1) Contact the vendor because disassembly and inspection are required.	Vendor
	The rotation speed is too high.	Check with the tachometer.	User
	The voltage is too high or too low. (2-2)	Check the power voltage.	User
	Fluctuation of the voltage	Contact the power company.	User
	A 50Hz pump is run in the 60Hz power zone.	Check the nameplate.	User
	The stator winding is broken, shorted, or grounded.	Contact the vendor because disassembly and inspection are required.	Vendor
	The stator and rotor are in contact due to wear of the bearing. (5-1)	Replace the bearing. (5-1) Contact the vendor because disassembly and inspection are required.	Vendor
	The specific gravity or dynamic viscosity of the pumping liquid is too high.	Reconsider the plan.	User
	The discharge rate is high.	Throttle the sluice valve to adjust the rate as per the specifications.	User
A rotating part is in contact with another part.	Contact the vendor because disassembly and inspection are required.	Vendor	
The pump starts, but cannot achieve the specified discharge rate and the specified head.	The pumping liquid contains many bubbles.	Prevent the formation and suction of bubbles.	User
	The rotation direction is reverse. (4-1)	Correct the wiring so that the motor rotates in normal direction. (4-2)	User
	The piping loss is high.	Check the diameter, route and length of the pipes.	User
	The piping is clogged with foreign matter.	Remove foreign matter and check the joints.	User
	The impeller is worn.	Replace the impeller. Contact the vendor because disassembly and inspection are required.	Vendor
	Foreign matter is accumulated in the impeller and in the casing.	Remove the foreign matter, and check the connections. Contact the vendor because disassembly and inspection are required.	Vendor
	The rotation speed is low.	Check with the tachometer.	User
	The sluice valve is closed.	Open the sluice valve.	User

Problem	Cause (Reference page)	Action (Reference page)	Done by *
The pump starts, but cannot achieve the specified discharge rate and the specified head.	The piping is clogged with foreign matter.	Check and clean the piping.	User
	The strainer on the suction port is clogged.	Check and clean the strainer.	User
	The impeller is not submerged in the liquid.	Loosen the air vent valve to release air to the atmosphere. Confirm that the liquid is discharged, and then close the valve.	User
	The suction port is exposed above the liquid level. (3-2)	Adjust the liquid level, for example, by refilling the tank with the liquid or by lowering the installation position of the pump.	User
	There is a leak in the discharge pipe.	Check and repair the pipe.	Vendor
Overheat of bearing	The bearing is worn or damaged. (5-1)	Replace the bearing. (5-1) Contact the vendor because disassembly and inspection are required.	Vendor
	The grease is deteriorated.		
	Incorrect installation of the pump and the piping (3-2)	Check and correctly install them.	User
Unusual noise and unusual vibration of the pump	The bearing or the metallic part of bearing is worn or damaged. (5-1)	Replace the bearing or the metallic part of bearing. (5-1) Contact the vendor because disassembly and inspection are required.	Vendor
	The motor is running in open-phase condition.	Check the wiring.	User
	The impeller is clogged with foreign matter, thus leading to imbalanced load.	Disassemble and check. Contact the vendor because disassembly and inspection are required.	Vendor
	Cavitation has occurred.	Contact the manufacturer and vendor.	User
	Incorrect installation of the pump and the piping (3-2)	Check and correctly install them.	User
Leakage from the immersion detection hole	Abnormal condition of the shaft seal	Check and repair the shaft seal. Contact the vendor because disassembly and inspection are required.	Vendor
Water hammer occurs.	Hammering has occurred when the valve is rapidly opened and closed.	Provide a pressure damper (e.g. accumulator).	User

* The persons who take the Action are specified here (Done by) only as a guide because the extent of actions that can be taken is different depending on the user.

If you have anything unclear—even about the problems whose actions to be done by User, ask the vendor or contact Teral.

7. After-sales service



For overhaul, replacement of parts, or repairs, ask the vendor, the service provider specified by the manufacturer, or Teral.
Improper work may lead to malfunctions or accidents.

- For maintenance and repairs of the pump, ask the vendor from which you purchased the product or ask Teral.
- If you find anything unusual about the active pump, immediately stop the pump and then check the problem. (Refer to Section “6. Troubleshooting” [page 6-1].) For disassembly, inspection, or repair, ask the vendor from which you purchased the product or ask Teral. (Refer to the end of this document.)
- Never repair the pump by yourself because it may lead to danger.
- When you contact the vendor, inform them of the information indicated on the pump nameplate (e.g. pump model and serial number) in addition to the status of the problem.
- For the warranty, refer to “Limited warranties [page I]” on the opening page of this document.

If you have anything unclear about the product, contact the vendor from which you purchased the product or contact Teral.

8. Disposal

8.1 Precautions for disposal

Before detaching the pump from the system for disposal or replacement, be sure to turn off the main power.



Before detaching the pump, be sure to turn off the main power. Otherwise, the pump may suddenly start up in automatic mode or on other occasions, thus leading to great danger.



When hoisting the pump, pay attention to its center of gravity. Otherwise, the pump may topple over or fall, thus leading to an injury.

- (1) Drain liquid from the tank (oil tank) so that the bottom of the pump is exposed above the liquid level.
- (2) Close the sluice valve on the discharge side and open the air vent valve of the pump to discharge liquid from the pump.
- (3) Disconnect the wiring and piping. (For the layout in the terminal box, refer to “Section 3.5. Precautions for wiring work [page 3-5].”)
- (4) Remove the pump mounting bolts and coupling cover, pass a nylon sling or the like through the lifting points of the pump, and then hoist the pump. (Refer to “Section 3.3 Precautions for installation [page 3-2].”)

Because the liquid remaining in the pump may flow out while the pump and piping are detached or moved, take measures against it, if necessary, before carrying out this work.



When you handle the pump, do not hold the strainer located on the tip of the pump. Otherwise, the strainer may come off, thus leading to an injury or damage.

- (5) Dispose of the pump as industrial waste. Dispose of other parts according to your national and local laws and regulations, for example, by asking the specialized waste disposal contractor.

Note

Dispose of the pump as industrial waste.

Note

For the packing materials that are no longer necessary after installation as well as for used lubricating oils and parts that are no longer necessary after maintenance, inspection, repairs, and replacement, dispose of them according to your national and local laws and regulations, for example, by asking the specialized waste disposal contractor.

TERAL
TERAL INC.

Head Office

230, Moriwake, Miyuki-cho, Fukuyama-city, Hiroshima, 720-0003, Japan
Tel.+81-84-955-1111 Fax.+81-84-955-5777

www.teral.net